

This Copy is a reprint which includes current pages from Change 1 through 3.

TECHNICAL MANUAL

OPERATOR'S AND ORGANIZATIONAL
MAINTENANCE MANUAL WITH PARTS LIST

DIVING EQUIPMENT SET
(SCUBA, TYPE B)

NSN 4220-01-023-1701

COMPRESSOR, RECIPROCATING, POWER DRIVEN,
AIR, DIESEL ENGINE, 20 CFM, 3200 PSI
TYPE DMC-AA, MODEL 1C41-RDOW
PART NUMBER 83207

NSN 4310-01-044-2301

MANIFOLD SERVICING UNIT, CASCADE
COMPRESSED GAS, AIR
TRAILER MOUNTED, TYPE 1
PART NUMBER 83208

NSN 4220-01-005-0704

MANIFOLD SERVICING UNIT, DUAL
AIR/OXYGEN
TRAILER MOUNTED, TYPE II
PART NUMBER 83209

NSN 4220-01-005-3276

COMMERCIAL TRAILER
MODEL CT-1
PART NUMBER 86169

WARNING

When the system being charged is not protected by a safety valve, do not have charging hose connected to the unprotected system/s after desired pressure is reached. Do not allow service pressure to exceed charging application.

Use of low pressure air will contaminate air purification and dehydrator system cartridges. Do not use less than 2300 psi as a pressure source to charge this system.

Do not use any volatile or petrol base solvents/solutions or mixtures to clean the interior or exterior of the air purification and dehydrator cylinders or applicable tubing. Toxic or contaminated air may result.

Do not direct air stream toward body. Serious injury or death may result from high pressure air entering the skin.

Do not operate the air compressor for breathable air purposes, without first making sure that the proper cartridges are installed in the dehydrator and air purification system of this air compressor unit. Insure that the applicable cartridges are not contaminated.

Check air compressor unit hose and tubing for chaffing conditions after each use, or when the unit has either been moved or shipped.

a/(b Blank)

CHANGE
NO. 3

HEADQUARTERS
DEPARTMENT OF THE ARMY
WASHINGTON, D.C., 3 JULY 1992

Operator's and Organizational Maintenance Manual
with Parts List

DIVING EQUIPMENT SET
(SCUBA, TYPE B)
NSN 4220-01-023-1701
COMPRESSOR, RECIPROCATING, POWER DRIVEN,
AIR, DIESEL ENGINE, 20 CFM, 3200 PSI
TYPE DMC-AA, MODEL IC41-RDOW
PART NUMBER 83207
NSN 4310-01-044-2301
MANIFOLD SERVICING UNIT, CASCADE
COMPRESSED GAS, AIR
TRAILER MOUNTED, TYPE 1
PART NUMBER 83208
NSN 4220-01-055-0704
MANIFOLD SERVICING UNIT, DUAL
AIR/OXYGEN
TRAILER MOUNTED, TYPE II
PART NUMBER 83209
NSN 4220-01-005-3276
COMMERCIAL TRAILER
MODEL CT-1
PART NUMBER 86169

Approved for public release; distribution is unlimited

TM 5-4220-209-12&P, dated 6 February 1985, is changed as follows:

1. Remove and insert pages as indicated below. New or changed text material is indicated by a vertical bar in the margin. An illustration change is indicated by a miniature pointing hand.

Remove pages

8-71 through 8-74

Insert pages

8-71 through 8-74

2. Retain this sheet in front of manual for reference purposes.

By Order of the Secretary of the Army:

Official:

GORDON R. SULLIVAN
General, United States Army
Chief of Staff

MILTON H. HAMILTON
Administrative Assistant to the
Secretary of the Army
01884

DISTRIBUTION:

To be distributed in accordance with DA Form 12-25E, qty rqr block no. 4025.

CHANGE

NO. 2

HEADQUARTERS
DEPARTMENT OF THE ARMY
WASHINGTON, D.C., 10 October 1990

OPERATOR'S AND ORGANIZATIONAL
MAINTENANCE MANUAL WITH PARTS LIST

DIVING EQUIPMENT SET
(SCUBA, TYPE B)
NSN 4220-01-023-1701

COMPRESSOR, RECIPROCATING, POWER DRIVEN
AIR, DIESEL ENGINE, 20 CFM, 3200 PSI
TYPE DMC-AA, MODEL IC41-RDOW
PART NUMBER 83207
NSN 4310-01-044-2301

MANIFOLD SERVICING UNIT, CASCADE
COMPRESSED GAS, AIR
TRAILER MOUNTED, TYPE 1
PART NUMBER 83208
NSN 4220-01-005-0704

MANIFOLD SERVICING UNIT, DUAL
AIR/OXYGEN
TRAILER MOUNTED, TYPE II
PART NUMBER 83209
NSN 4220-01-005-3276

COMMERCIAL TRAILER
MODEL CT-1
PART NUMBER 86169

Approved for public release; distribution is unlimited

TM 5-4220-209-12&P, 6 February 1985, is changed as follows:

1. Remove and insert pages as indicated below. New or changed text material is indicated by a vertical bar in the margin. An illustration change is indicated by a miniature pointing hand.

Remove pages

1-5 and 1-6
5-3 and 5-4

Insert pages

1-5 and 1-6
5-3 and 5-4

2. Retain this sheet in front of manual for reference purposes.

By Order of the Secretary of the Army:

CARL E. VUONO
General, United States Army
Chief of Staff

Official:

THOMAS F. SIKORA
Brigadier General, United States Army
The Adjutant General

DISTRIBUTION:

To be distributed in accordance with DA Form 12-25E, (qty rqr block no. 4025)

CHANGE

NO. 1

HEADQUARTERS
DEPARTMENT OF THE ARMY
WASHINGTON, D.C. 28 February 1986

OPERATOR'S AND ORGANIZATIONAL
MAINTENANCE MANUAL WITH PARTS LIST
DIVING EQUIPMENT SET
(SCUBA, TYPE B)
NSN 4220-01-023-1701

COMPRESSOR, RECIPROCATING, POWER DRIVEN,
AIR, DIESEL ENGINE, 20 CFM, 3200 PSI
TYPE DMC-AA, MODEL 1C41-RDOW
PART NUMBER 83207
NSN 4310-01-044-2301

MANIFOLD SERVICING UNIT, CASCADE
COMPRESSED GAS, AIR
TRAILER MOUNTED, TYPE 1
PART NUMBER 83208
NSN 4220-01-005-0704

MANIFOLD SERVICING UNIT, DUAL
AIR/OXYGEN
TRAILER MOUNTED, TYPE II
PART NUMBER 83209
NSN 4220-01-005-3276
COMMERCIAL TRAILER
MODEL CT-1
PART NUMBER 86169

TM 5-4220-209-12&P, 6 February 1985, is changed as follows:

1. Remove and insert pages as indicated below. New or changed text material is indicated by a vertical bar in the margin. An illustration change is indicated by a miniature pointing hand.

Remove pages

Insert pages

A-1 through A-17/A-18
B-1 thru B-3/B-4

2. Retain this sheet in front of manual for reference purposes.

By Order of the Secretary of the Army:

Official:

JOHN A. WICKHAM, JR.
General, United States Army
Chief of Staff

MILDRED E. HEDBERG
Brigadier General, United States Army
The Adjutant General

DISTRIBUTION:

To be distributed in accordance with DA Form 12-21A, Requirements for FSC Group 4220 Marine Lifesaving and Diving Equipment.

REPORTING ERRORS AND RECOMMENDING IMPROVEMENTS

You can help improve this manual. If you find any mistake or if you know of a way to improve the procedures, please let us know. Mail your letter, DA Form 2028 (Recommended Changes to Publications and Blank Forms), or DA Form 2028-2 located in the back of this manual direct to: Commander, U. S. Army Troop Support Command, ATTN: AMSTR-MPS, 4300 Goodfellow Boulevard, St. Louis, MO 63120-1798. A reply will be furnished directly to you.

TABLE OF CONTENTS

CHAPTER I

Compressor, Reciprocating, Power Driven
 Air, Diesel Engine, 20 CFM, 3200 PSI
 Type DMC-AA, Model 1C41-RDOW
 Part Number 83207 (16004) 1-1

CHAPTER II

Manifold Servicing Unit, Cascade
 Compressed Gas, Air
 Trailer Mounted, Type I
 Part Number 83208 (16004) 1-1

Manifold Servicing Unit; Dual
 Air/Oxygen
 Trailer Mounted, Type II
 Part Number 83209 (16004) 1-1

CHAPTER III

Commercial Trailer, CT-1
 Model CT-1
 Part Number 86169 (16004) 1-1

CHAPTER I

TABLE OF CONTENTS

Section/ Para	Page	Section/ Para	Page
I.	INTRODUCTION AND.....	5-2	Operational Checkout.....5-1
	GENERAL INFORMATION	5-4	Inspection and Preventative Maintenance.....5-2
1-1	Introduction	5-24	Lubrication Instructions
1-2	General Information.....	5-31	Troubleshooting.....5-18
1-3	Description		
1-13	Consumable Material		
II.	SPECIAL TOOLS AND TEST EQUIPMENT..	VI.	REPAIR INSTRUCTIONS
2-1	General.....	6-1	Repair.....6-1
2-2	Special Tools and Test Equipment.....	6-3	Air Compressor Unit
		6-4	Disassembly of Major Components
III.	PREPARATION FOR USE AND SHIPMENT.	6-42	Table of Limits
3-1	General.....	6-44	Test
3-2	Preparation for Use	VII.	DIAGRAMS
3-3	Preparation for Storage or Shipment...	7-1	General.....
7-2	Diagrams	7-3	Symbols.....
IV.	OPERATION INSTRUCTIONS	7-4	Reference Designation
4-1	General.....	7-5	Index of Diagrams
4-2	Theory of Operation	VIII.	ILLUSTRATED PARTS BREAKDOWN.....
4-32	Operation Instructions	8-1	General.....
V.	MAINTENANCE INSTRUCTIONS	8-2	Maintenance Parts List
5-1	General.....		

LIST OF ILLUSTRATIONS

Figure	Page	Figure	Page
1-1	Type DMCAA Air Compressor,.....	5-14	Engine Tappet Adjustment
	Model 1C41-RDOW	5-15	Engine Compression Adjustment
2-1	Engine Special Tool Kit	5-16	Engine Compression Adjustment Tolerances.....
4-1	Air Flow Diagram	5-17	Fuel Injector Nozzle.....
4-2	Operating Controls and Indicators.....	5-18	Engine Oil Filter
5-1	Pressure Switch Adjustment	5-19	Compressor Oil Filter
5-2	Air Compressor Air Filter	5-20	Priming Air Compressor Assy.Oil Pump
5-3	Engine Air Filter	6-1	Steel Tubing and Fitting Assy.....
5-4	Dehydrator Cylinder	6-2	Presetting Tubing Sleeve
5-5	Engine Fuel Filter	6-3	Priority Valve Test Setup
5-6	Mechanical Filter	6-4	Setting Priority Valve Elbow
5-7	Ten Micron Filter	6-5	Typical Safety Valve Test Setup.....
5-8	First, Second and Third Stage Traps ..	6-6	Oil Seal, Crankshaft
5-9	Line Strainers	6-7	Non-Drive End Cover, Oil Pump & Oil Seal Installation
5-10	Clutch Adjusting Yoke Adjustment	6-8	Lentoid Spring Assy.Detail
5-11	Clutch Operating Rod Adjustment	6-9	Bleed Valve Port Locations
5-12	Air Compressor Crankcase Filter		
5-13	Engine Crankcase Breather Sieve		

LIST OF ILLUSTRATIONS- Continued

Figure	Page	Figure	Page
6-10	Pressure Switch Test Setup 6-38	8-11	Air Compressor Group 8-21
6-11	Compression Adjustment 6-49	8-12	Air Compressor Assy. (Sheet 1 of 3) 8-23
6-12	Compression Adjustment Check 6-49	8-12	Air Compressor Assembly (Sheet 2 of 3) 8-25
6-13	Removing Retainer From Swap Ring 6-53	8-12	Air Compressor Assembly (Sheet 3 of 3) 8-27
6-14	Removing Snap Ring From Armature 6-53	8-13	Air Cleaner Assembly 8-29
6-15	Grounded Armature Test Setup 6-54	8-14	First Stage Head, Cylinder, and Piston Group 8-31
6-16	Field Winding Test Setup 6-55	8-15	Second Stage Head, Cylinder, and Piston Group 8-32
6-17	Testing Commutator Frame 6-55	8-16	Third Stage Head, Cylinder, and Piston Group 8-33
6-18	Snap Ring Expansion Tool 6-56	8-17	Fourth Stage Head and Cylinder Group 8-34
6-19	Assembly Snap Ring to Armature 6-56	8-18	Fourth Stage Piston and Pin Assembly 8-35
6-20	Assembly Snap Ring and Retainer 6-56	8-19	Clutch, Clutch Housing Group (Sheet 1 of 2) 8-36
6-21	Cleaning The Nozzle Tip 6-60	8-29	Clutch, Clutch Housing Group (Sheet 2 of 2) 8-38
6-22	Cleaning The Orifice Holes 6-60	8-20	Trap and Accumulator Group 8-39
6-23	Cleaning Nozzle and Seat 6-60	8-21	First Stage Trap Assembly 8-41
6-24	Cleaning Nozzle Valve 6-61	8-22	Second Stage Trap Assembly 8-42
6-25	Inspecting Mating Surfaces 6-61	8-23	Third Stage Trap Assembly 8-43
6-26	Checking Freedom of Valve in Nozzle 6-61	8-24	Accumulator Assembly 8-44
6-27	Fuel Injector Spray Pattern 6-62	8-25	Bleed Valve Assembly 8-45
6-28	Spring Plate to Camshaft Adjustment 6-73	8-26	Bleed Valve Subassembly 8-46
6-29	Continuous Bleed Valve Assembly 6-74	8-27	Drain Valve Assembly 8-47
6-30	Compressor Oil Seal Cover 6-74	8-28	Unloader Control Box Group 8-49
6-31	Outer Oil Pump Cover 6-74	8-29	Condensate Receiver Group 8-51
6-32	Non Drive End Cover 6-75	8-30	Diesel Engine Assembly (Sheet 1 of 10) 8-53
6-33	Oil Pump Rotor 6-75	8-30	Air Intake and Guard Group (Sheet 2 of 10) 8-55
6-34	Oil Pump Blade 6-75	8-30	Fuel System (Sheet 3 of 10) 8-57
6-35	Oil Pump Inner Cover 6-76	8-30	Piston, Cylinder and Crank Group (Sheet 4 of 10) 8-60
6-36	Drive End Cover 6-76	8-30	Crankcase Assembly (Sheet 5 of 10) 8-63
6-37	Flywheel and Drive Sheave 6-76	8-30	Crankcase Assembly (Sheet 6 of 10) 8-65
6-38	Connecting Rods 6-77	8-30	Cam, Pushrod and Head Group (Sheet 7 of 10) 8-67
6-39	Compressor Crankshaft 6-77	8-30	Blower Group (Sheet 8 of 10) 8-70
6-40	First Stage Cylinder, Piston and Pin Assy. 6-78	8-30	Blower Group (Sheet 9 of 10) 8-72
6-41	Second Stage Cylinder, Piston and Pin Assy. 6-78	8-30	Engine Electrical Accessories (Sheet 10 of 10) 8-74
6-42	Third Stage Cylinder , Piston and Pin Assy. ... 6-78	8-31	Starting Motor Assembly 8-76
6-43	Fourth Stage Cylinder and Liner 6-78	8-32	Alternator 8-78
6-44	Fourth Stage Piston and Pin Assy 6-79	8-33	Engine Air Filter 8-80
6-45	Drain Valve Assy 6-79	8-34	Fuel Feed Pump Assembly 8-81
7-1	Air Flow Diagram 7-2	8-35	Fuel Injection Pump Subassembly 8-82
7-2	Wiring Diagram 7-3	8-36	Fuel Injector Subassembly 8-83
8-1	Air Compressor Unit 8-5	8-37	Fuel Filter Subassembly 8-84
8-2	Dehydrator and Air Purification Group 8-7	8-38	Frame Group 8-85
8-3	Mechanical Filter Assembly 8-9	8-39	Tubing Identification 8-87
8-4	Dehydrator Cylinder Assembly 8-10		
8-5	priority Valve Assembly 8-11		
8-6	Ten-Micron Filter Assembly 8-12		
8-7	Control Panel Assembly (Sheet 1 of 2) 8-13		
8-7	Control Panel Assembly (Sheet 2 of 2) 8-14		
8-8	Instrument Panel Assembly 8-16		
8-9	Rupture Disc Assembly 8-18		
8-10	Air Cooler Group 8-19		

LIST OF TABLES

Number	Page	Number	Page
1-1	Table of Leading Particulars 1-1	5-2	Inspection, Checks and Services 5-3
1-2	Consumable Materials 1-5	5-3	Lubrication Instructions..... 5-16
2-1	Special Tools and Test Equipment 2-1	5-4	Troubleshooting..... 5-19
5-1	Instrument Panel Meter and Gauge Indication 5-1	6-1	Table of Limits..... 6-64
		6-2	Miscellaneous Table 6-72

**CHAPTER I
SECTION I.
INTRODUCTION AND GENERAL INFORMATION**

1-1. INTRODUCTION. This manual contains operation and maintenance instructions with illustrated parts breakdown for the Type DMC-AA Air Compressor, Model 1C41-RDOW, Part Number 83207. Leading features of the unit are listed in Table 1-1. Model IC41-RDOW air compressor is shown in Figure 1-1, and hereafter referred to as the air compressor unit.

temperature range of the air compressor unit is -250 to 1200F (-320 to 430C) at altitudes up to 5,000 feet (1.5 Km). The air compressor unit is used to produce air suitable for breathing purposes. Air volume of 20 cfm at 3200 psi (22,048 kPa) is available for air breathing requirements. The air compressor unit is air transportable and is designed to operate under extreme climactic conditions.

1-2. GENERAL INFORMATION. The air compressor unit is a portable, skid mounted, diesel engine driven, reciprocating, air compressor. It is designed for continuous operation at a rated capacity of 20 scfm (0.43 m3/s) at pressures up to 3,200 psig(22,058 kPa). The compressed air is filtered to a solid particle size of 10 microns. Operating

NOTE

The front of the air compressor unit contains the control panel. When the operator is facing the control panel, the right-hand side is to the operator's right, the left-hand side is to the operator's left. The rear is the engine end of the air compressor unit.

Table 1-1. Table of Lending Particulars

ITEM	PARTICULARS
AIR COMPRESSOR UNIT	Military Specification MILC-52973 (ME)
Specification	Reciprocating
Type	20 scfm (0.57 m3/min)
Air volume	3200 psig (22,048 kPa)
Air pressure (max.)	Diesel engine
Power source	-250F to 1200F (-320 to 430C)
Operating temperature range	Frame shock mounted on skid.
Mounting	12 vdc, neg. gnd.
Electrical system	60 in. (2,124 mm)
Length (OA)	48 in. (1,219 mm)
Width (OA)	50 in. (1,270 mm)
Height (OA)	144 cu. ft. (4.07m3)
Volume	1,542 lbs. (680.4 Kg)
Weight (dry)	
AIR COMPRESSOR ASSEMBLY	
Type	4 stage, radial. reciprocating
Number of cylinders	4
Cooling	Forced air
DIESEL ENGINE ASSEMBLY	
Specification	Military Standard MIL-STD-1410
Type	4 stroke-cycle, reciprocating
Number of cylinders	2
Bore and stroke	4.20 in. (108 mm) x 4.33 in. (110 mm)
Displacement	77.5 cu in. (1.27 ltr)
Operation speed	2,150 rpm (2,150 r/min)
horsepower	25 HP
Combustion Method	Direct injection
Cooling	Forced air
Compression ratio	18:1

Table 1-1. Table of leading Particulars - Continued

ITEM	PARTICULARS
ENGINE ACCESSORIES Starting motor Alternator Fuel	12 vdc 20 amp, 14 vdc, negative ground ASTM D975-Nr. 2 diesel
CLUTCH ASSEMBLY Type	Dry, single plate, manually operated
CAPACITIES Fuel tank Engine lubricating oil - With filter change - Without filter change Compressor lubricating oil - With filter change - Without filter change	16-3/4 gallons (62 ltr) 6.2 quarts (6 ltr) 5.2 quarts (5 ltr) 5 quarts (4.7 ltr) 4 quarts (3.8 ltr)

1-3. DESCRIPTION. The air compressor is a self contained unit consisting of nine major groups; the control panel; dehydrator and air purification group; trap/accumulator mounting group; air cooler assembly; air compressor group; clutch, unloader control and drain valve; engine group; frame and skid group. (See Figure 1-1).

1-4. **CONTROL PANEL GROUP** (1, Figure 1-1). The control panel group consists of dehydrator/air purification assembly, control panel and the instrument panel assembly. Shock mounts on the instrument panel protects the gauges and meters from excessive vibration during unit operation. All operating controls and indicators are located on either the control panel or instrument panel. The air cooler subassembly is attached to the inside of the control panel. Two removable sliding cooler doors attached to the control panel allow the area of the air cooler exhaust to be varied for best operation of the air cooler. Clamps on the cooler doors allow for stationary positioning of the doors. The control panel is also attached to the frame and skid group.

1-5. **DEHYDRATOR AND AIR PURIFICATION GROUP** (13, Figure 1-1). This group consists of a mechanical filter subassembly (13), two dehydrators and priority valve (11, 12), three air purification cylinders (6, 7 and 8) and a ten micron filter (3). The mechanical filter removes oil, moisture, and air-borne foreign particles from the pressurized air prior to the air entering the dehydrators. Each dehydrator contains an oxygen purifier cartridge (MA-2). The dehydrator removes oil and moisture from the pressurized air. The air purification cylinders use the (-I-13X oil vapor removal cartridge, CO 6 carbon monoxide removal cartridge and C-I-AC activated charcoal air freshner cartridge. The cartridges perform these functions

through absorption and catalytic action. Records should be maintained for each dehydrator and air purification cylinder, so that elapsed time of use for each purifier cartridge in each cylinder can be maintained. The ten micron filter subassembly contains a replaceable filter element. This element traps any remaining foreign particles larger than ten microns and traps any condensate remaining in the pressurized air.

1-6. **TRAP AND ACCUMULATOR MOUNTING GROUP** (21, Figure 1-1). This group is mounted on the left side of the air compressor unit on the frame and skid group behind the control panel. Attached to the trap mount are the first through third stage trap subassemblies and the accumulator cylinder. This group helps to separate excessive water and oil residue from the pressurized air.

1-7. **AIR COOLER SUBASSEMBLY** (10, Figure 1-1). The air cooler subassembly removes the heat of compression from the air between stages. Air compressed in the first stage cylinder passes through the first stage air cooler and moisture separator into the second stage cylinder. Similarly, air compressed in the second stage cylinder passes through the second stage air cooler and moisture separator into the third stage cylinder. Air compressed in the third stage cylinder passes through the third stage air cooler and moisture separator into the fourth stage cylinder. Air compressed in the fourth stage cylinder passes through the fourth stage air cooler, mechanical filter, dehydrators, and into the air purification system. Air passing through the air coolers lowers the air temperature. This increases compressor efficiency. Also, condensed water and oil is removed between 1-2

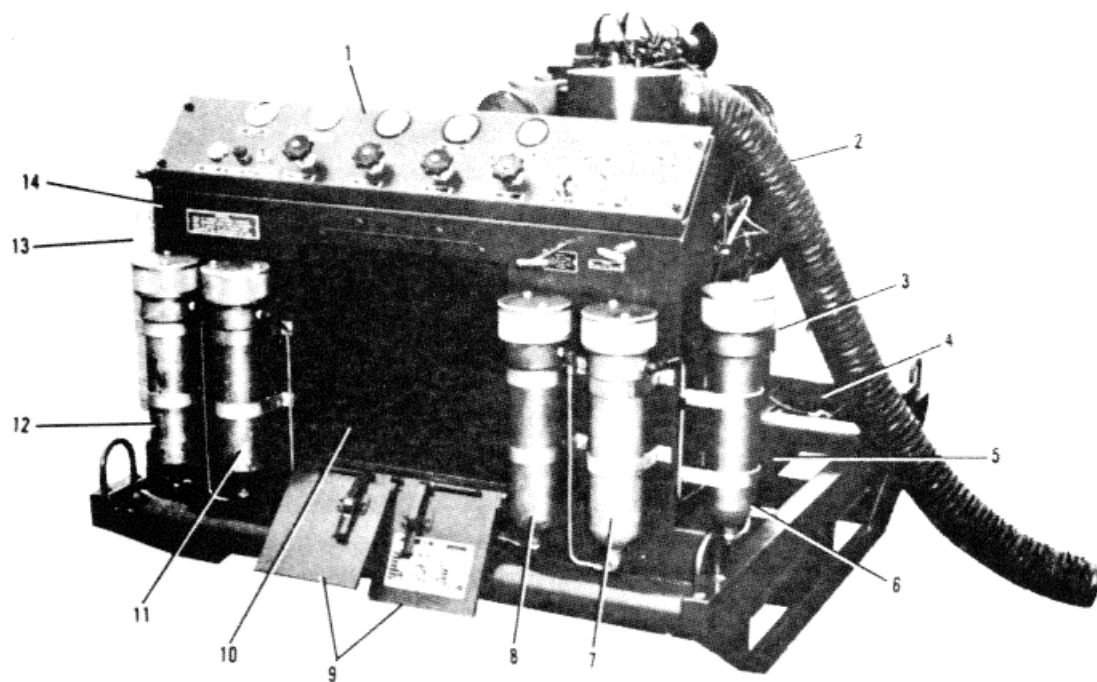

FRONT

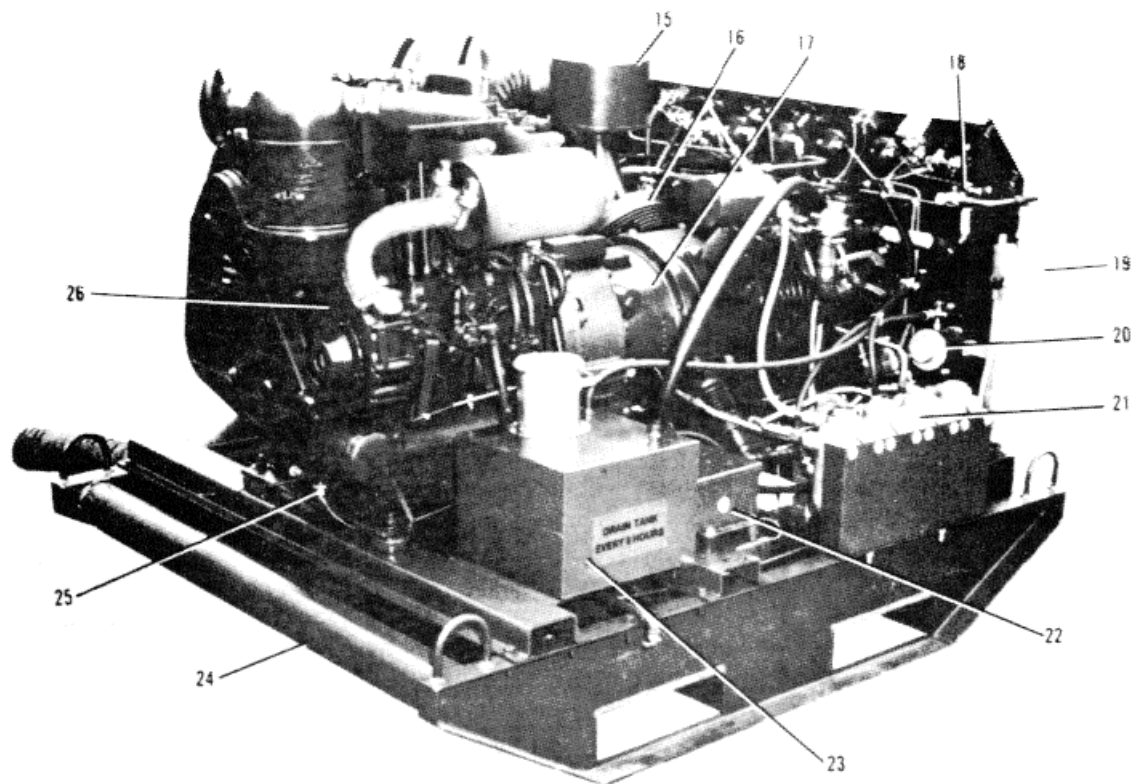

LEFT SIDE REAR

Figure 1-1. Air Compressor Unit

- | | |
|---|-------------------------------------|
| 1. INSTRUMENT PANEL | 14. CONTROL PANEL |
| 2. HOSE, AIR BREATHER | 15. COVER, AIR BREATHER, COMPRESSOR |
| 3. TEN-MICRON FILTER | 16. COMPRESSOR, AIR |
| 4. BATTERY MOUNT | 17. CLUTCH |
| 5. FUEL TANK | 18. RUPTURE DISC |
| 6. AIR PURIFICATION CYL NO. 5, C-1-AC CARTRIDGE | 19. MECHANICAL FILTER |
| 7. AIR PURIFICATION, CYL NO. 4, CO-6 CARTRIDGE | 20. BLEED VALVES |
| 8. AIR PURIFICATION, CYL NO. 3, C-1-13X CARTRIDGE | 21. TRAP GROUP |
| 9. AIR COOLER DOORS | 22. UNLOADER CONTROL BOX |
| 10. AIR COOLER | 23. CONDENSATE RECEIVER |
| 11. DEHYDRATOR CYL NO.2, MA-2 CARTRIDGE | 24. FRAME |
| 12. DEHYDRATOR CYL NO. 1, MA-2 CARTRIDGE | 25. OIL PRESSURE SWITCH |
| 13. MECHANICAL FILTER | 26. DIESEL ENGINE |

stages prior to entering the dehydrators. Cooling is accomplished by air being drawn through the cooler subassembly by the fan mounted on the compressor crankshaft. Hinged doors are provided on the control panel. These doors control the amount of air drawn through the cooler assembly and blown over the compressor assembly. Each air cooler stage is equipped with a pressure relief safety valve.

1-8. AIR COMPRESSOR GROUP (16, Figure 1-1). The air compressor assembly is a four cylinder, air-cooled, radial compressor. Compression of air from initial intake to final discharge is accomplished in four distinct stages. Discharge pressure is indicated on the instrument panel pressure gauges. Lubrication of the moving parts is provided by an oil pump located in the non-drive end cover. A air circulating fan mounted on the non-drive end of the crankshaft is used to circulate air over the compressor assembly.

1-9. CLUTCH AND HOUSING GROUP (17, Figure 1-1). The clutch group is a single plate, manually operated, dry type clutch. A clutch rod and hand lever are used to operate the clutch. The clutch rod extends to the rear and through the control panel. This allows the operator to engage and disengage the clutch. The clutch housing aligns the engine with the air compressor. A cover on the housing allows access to the clutch.

1-10. ENGINE AND ACCESSORIES GROUP (26, Figure 1-1). The diesel engine assembly is a four stroke cycle, direct injection, air cooled, diesel engine. The engine is used to drive the air compressor through the manually operated clutch.

at a rated speed of 2,150 rpm (2,150 r/min). Engine accessories include a 12V alternator, intake air filter, fuel filter, lubricating oil filter, and electrical starting motor. Operating controls for the engine are located on the control panel assembly. The AMMETER, & ENGINE OIL PRESSURE gauge are located on the instrument panel.

1-11. DRAIN VALVE ASSY. AND UNLOADER CONTROL BOX GROUP (22, Figure 1-1). When air pressure in the system reaches a pre-determined value, a pressure switch in the unloader control box will open. This ceases loading of the compressor. The drain valve assembly will then open, allowing moisture and air to be exhausted to the condensate receiver assembly.

1-12. FRAME AND SKID GROUP (24, Figure 1-1). The frame on which all the major components are mounted is welded, single unit frame work. The air compressor, clutch assembly and engine are shock mounted to the skid by steel cross members. A fuel tank with capacity for not less than eight hours of operation is mounted inside the frame work. There are lifting and tie-down eyes at each corner of the frame. These allow the complete unit to be hoisted without damage. The eyes may also be used for tying down the air compressor unit. Provisions have been incorporated in the frame/skid to allow movement of the air compressor unit by using the proper size fork lift truck.

1-13. CONSUMABLE MATERIALS. Refer to Table 1-2 for a listing of consumable materials.

Table 1-2. Consumable Materials

NOMENCLATURE	MATERIAL	SPECIFICATION NUMBER	GOVERNMENT STANDARD NO.	PART NUMBER
Air Purification Cyl No. 3	Cartridge			C-1-13X
Air Purification Cyl No. 4	Cartridge			CO6
Air Purification Cyl No. 5	Cartridge			C-I-AC
Cleaning	Solvent Detergent	P-D680, Type II P-D-220		
Engine crankcase	Oil, lubricating, engine	MIL-L-2104 +125° F (+520 C) to +60° F (+130 C) +60° F (+130 C) to -0° F (-18° C) SAE 10W-30 +50° F (+100 C) to +86° F (+30° C) During operation in extreme heat, dusty, or sandy areas	MIL-STD-605	OE/HDO-30
				OE/HDO-10
				OE/HDO-30
Compressor crankcase compressor	Oil, lubricating,	MIL-L-26087		
Lubrication fittings	Grease, automotive and artillery	MIL-G-10924		
Fuel tank	Diesel fuel	ASTM D975-Nr. 2D		Nr.2 diesel
Battery	Electrolyte		MIL-STD-605	
Engine fuel filter	Element			Davey PN 82267
Engine air filter	Oil, lubricating, engine	MIL-L-2104 +125° F (+52° C) to +60° F (+130 C) +60° F (+130 C) to -0° F (-180° C) During operation in extreme heat, dusty, or sandy areas	MIL-STD-605	OE/HDO-30
				OE/HDO-10
				OE/HDO-30

Table 1-2. Consumable Materials (Continued)

NOMENCLATURE	MATERIAL			
Engine oil filter	Cartridge			Davey pn 82042
Compressor air filter	Element	MIL-L-17331		Davey pn 27248
Compressor oil filter	Cartridge			Puralator pn PER-I
Dehydrator	Cartridge	MIL-C-26058	MA-2, Cyl I and Cyl 2	
Filter, 10 micron	Element	MIL-F-5504	AN6235-2A	
Mechanical filter	Element		MF-1-5817	
Battery cables	Petrolatum, technical Tape, pressure sensitive Coating system, elastometric	VV-P-236 MIL-T431 1S MILC-7439		
Identification plates (processing)	Compound/insulating	MIL-V-1 137		
Frame (processing)	Corrosion preventive compound	MIL-C-16173		
Electrical System (processing)	Varnish, insulating Trichloroethane, technical inhibited	MIL-V-173 O-T-620		
Diesel engine (processing)	Lubricating oil, general purpose preservative	VV-L-800		
Engine exhaust muffler	Compound, preservative	MIL-C-16173 Gr 1		
Fuel tank (processing)	Lubricating oil, preservative	MIL-L-21260		
Fittings (leak proofings)	Tape, antiseize	MIL-T-27730		
Tubing and fittings (joining)	Sealing, Lubricating, and Wicking Com- pounds: Thread- Locking Anaerobic, Single Component	MIL-L-46163		
Valves (grinding)	Compound, grinding	SS-C-614		
Nicks and burrs (removing)	Cloth, abrasive, crocus	P-C-458		

SECTION II.

SPECIAL TOOLS AND TEST EQUIPMENT

2-1. GENERAL. This section contains special tools and test equipment required for inspection, repair, and testing of air compressor unit components and the assembled air compressor unit.

2-2. SPECIAL TOOLS AND TEST EQUIPMENT. Special tools and test equipment required for organizational and intermediate maintenance are listed in Table 2-1.

Table 2-1. Special Tools and Equipment List

TOOL/EQUIPMENT NO.	FIGURE NO.	NOMENCLATURE	USE AND APPLICATION
A-91B (Equivalent)	2-1	Wrench, Stop (Snap-on Tool Corp.)	Removing dehydrator cylinder caps and oil filters.
67939 (Equivalent)		Installation Sleeve, Rear Pump Cover and Seal (Davey Compressor Co.)	Installation of air compressor assembly non-drive end oil seal and inner pump cover
FBM-320 (Equivalent)		Gauge, Feeler (Snap-on Tool Corp.)	Engine tappet adjustment
84343		Tool Kit, Engine Special (Davey Compressor Co.)	Special tools for disassembly and assembly of diesel engine
BB-4A (Equivalent)		Hydrometer (Snap-on Tool Corp.)	Check battery condition
GG-283 (Equivalent)		Gear Puller, Three Jaw (Snap-on Tool Corp.)	Removing gears, pulleys, etc.
PRS-8 (Equivalent)		Spreader, Piston Ring (Snap-on Tool Corp.)	Installing piston rings
RC-40C (Equivalent)		Compressor, Piston Ring (Snap-on Tool Corp.)	Installing piston in cylinder
NSN 5130 00 910 3350 (NSN 5120 00 910 3350)		Wrench, Torque, 0-2,400 ft lbs	Tightening of nuts and bolts
NSN 4940 00 164 8997 (Equivalent)		Cleaner, Ultrasonic	Cleaning of machined metal parts
NSN 5130 00 222 3905 (Equivalent)		Hone, Cylinder, Portable	Honing or resizing of cylinder bores
NSN 5130 00 222 3906		Hone, Cylinder, Electric	Honing or resizing of cylinder bores
PPC-714 (Equivalent)		Punch, Drive Pin (Snap-on Tool Corp.)	Driving out and in of roll pins

Table 2-1. Special Tools and Equipment List

TOOL/EQUIPMENT NO.	FIGURE NO.	NOMENCLATURE	USE AND APPLICATION
PR7 (Equivalent)		Pliers, Snap Ring (Snap-on Tool Corp.)	Removing and installing retaining rings
Model HG (Equivalent)		Gun, Heat (Aero-Dri Corp.)	Shrinking of heat shrinkable tubiug
68247		Installation Tool, Clutch (Davey Compressor Co.)	Installing of clutch on engine crankshaft
68959		Adjustment Tool, Clutch (Davey Compressor Co.)	Adjusting clutch adjusting yoke
8000A NSN 6625-00-322-8715		Multimeter, Digital (John Fluke Mfg. Co.)	Making voltage, current, and resistance checks
KDEP 2900 (Equivalent)		Cleaning Kit, Nozzle (Robert Bosch)	Cleaning fuel injection nozzle subassembly
RC-510 (Equivalent)		Groove Cleaner, Ring (Snap-on Tool Corp.)	Removing carbon from piston ring grooves
MT-326A (Equivalent)		Growler, Armature (Snap-on Tool Corp.)	Testing starter armature continuity
83740 Air End.		Test Stand, High Pressure	Test stand for high pressure air ends.

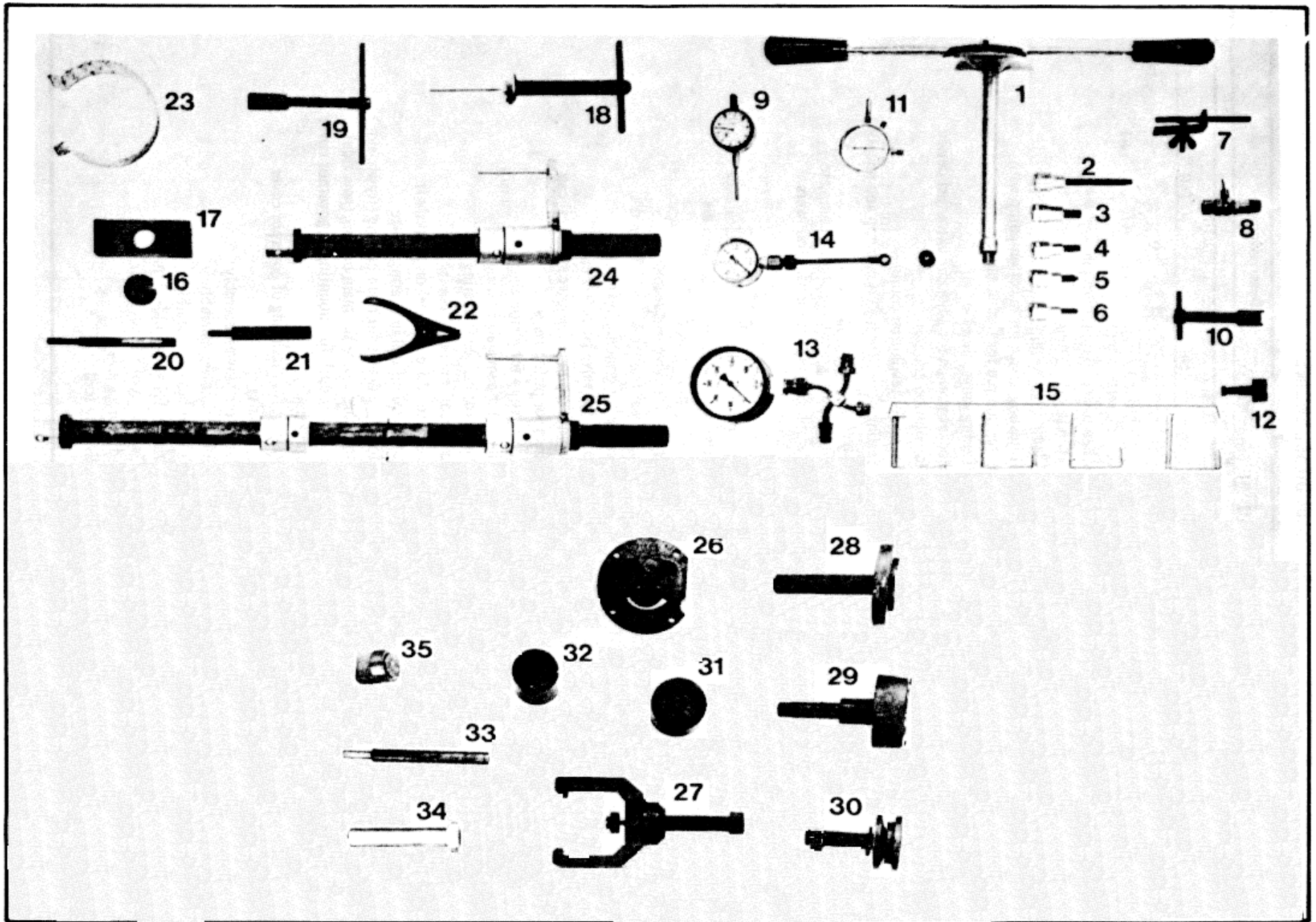

Figure 2-1. Engine Special Tool Kit

TOOLS, Z-108 DIESEL ENGINE

Tool Number	Part Number	Description
	84343	KIT, Tool, Z-108 DIESEL ENGINE
1	84344	Torque wrench, range 0-14 kpm (0-140 Nm)
2	84345	Multi-tooth socket 54 x M 8 K
3	82408	Allen insert 10 mm
4	69615	Allen insert 6 mm
5	84346	Allen insert 6 mm, with pin
6	69605	Allen insert 8 mm
7	84347	Clamp 1/2 fuel pipe
8	82411	Adjusting device for injection pump with extension pin for timing gauge
9	69601	Timing gauge, shock-proof
10	69597	Socket wrench for adjusting extra fuel device
11	84348	Revolution counter
12	84349	Insert for revolution counter
13	69600	Testing device for injection pump and injection valve
14	84350	Oil pressure gauge 0-6 kp/cm ³ , complete
15	84351	Clamping spring set for cam followers (1 set = 4 pcs.)
16	69598	Clamp for timing gauge
17	69599	Measuring bridge for bumping clearance
18	84352	Valve seat reamer 450, 52.5 mm dia.
	82413	Guiding pin 9 mm dia.
	69604	Handle for valve seat reamer
	84353	Valve seat reamer 45°, 47.5 mm dia.
19	84354	Handle for grinding in valves
20	82406	Punch for valve guide 9 mm dia.
21	84355	Mounting punch for valve stem seal cap
22	84356	Pliers for piston rings
23	84357	Fixing strap for piston rings
24	84358	Punch for camshaft bearing
25	84359	Punch for camshaft bearing
26	84360	Extractor for timing cover
27	84361	Extractor for gearwheel on crankshaft
28	84362	Punch for oil seal in bearing flange
29	84363	Mounting device for main bearing (flywh.-side)
30	84364	Mounting device for main bearing (gov. side)
31	84373	Auxiliary bush for mounting of governor cover (crankshaft)
32	84365	Bushing for mounting of governor cover (camshaft)
33	84366	Punch for blower-assembly
34	84367	Bolt for blower-assembly
35	84368	Bolt for blower-assembly
	84369	Reamer for valve guide 9 mm dia.
	84374	Clamping yoke for cylinder
	84375	Adjusting gauge
	84376	Riveting tool

SECTION III.

PREPARATION FOR USE AND SHIPMENT

3-1. GENERAL. The air compressor unit is 60 inches (1524 mm) long, 50 inches high (1270 mm), 48 inches (1219 mm) wide, and weighs 1542 pounds (680.4Kg). The compressor unit is shipped completely assembled and tested. There are, however, certain steps which shall be taken prior to putting the unit into operation. This section contains step-by-step procedures to be followed when preparing the unit for use, storage, or shipment.

3-2. PREPARATION FOR USE. To prepare the compressor unit for use, proceed as follows:

a. Remove all crating, blocking, and protective material from compressor unit.

WARNING

Wear goggles to prevent electrolyte from coming into contact with eyes. To prevent serious burns wear rubber gloves and apron when filling battery.

b. Fill each battery cell with electrolyte to a level of 1/4 inch to 1/2 inch above the top of the battery plates. Using a hydrometer, check the battery cells for a specific gravity of 1.250 or higher.

c. To deprocess the compressor unit, refer to DA Form 2258, Preservation and Depreservation Guide for Vehicles and Equipment.

d. Inspect unit for any damaged gauges, meters, valves, loose connections or mountings, loose or missing hardware, frayed insulation on wiring, or any other damage. Check all air tubing and hose for firm connections and damage that may have resulted from a chaffing condition. If damaged tube or hose assemblies exist, replace the damaged items as required.

WARNING

Connect ground battery cable last.

e. Connect battery cables. Unit is designed for negative ground.

f. Remove fuel tank filler cap and fill tank to capacity with recommended fuel (refer to Table 1-1). Replace filler cap.

g. Close all control valves on the control panel.

h. Perform procedures contained in PRIOR TO OPERATION (Section IV) and INSPECTION AND PREVENTIVE MAINTENANCE (Section V), refer to Table 5-2.

3-3. PREPARATION FOR STORAGE OR SHIPMENT.

Preparation for storage or shipment of the air compressor unit shall be in accordance with MIL-D-52838(ME).

3-1/(3-2 Blank)

SECTION IV.

OPERATION INSTRUCTION

4-1. GENERAL. This section describes the theory of operation, operating procedure, and the operating controls and indicators for the air compressor unit. The air compressor unit is designed to deliver contaminant free, dry breathable air under pressure up to a maximum of 3,200 psig (22,048 kPa) at a rate of 20 cfm. Air supply cylinders, 3500 psig (24115 kPa) may be serviced by the air compressor unit.

4-2. THEORY OF OPERATION. The reciprocating air compressor assembly is connected to the diesel engine power source by means of a manually operated clutch. Normal operating speed of the diesel engine is 2150 RPM. In the air compressor assembly, air is compressed to the desired pressure in four separate stages. The engine speed is controlled manually and protected by the internal engine governor control.

4-3. AIR COMPRESSING MODE (Figure 4-1). As the first compression stage piston travels downward, the pressure differential causes the first compression stage intake valve to open, drawing air from the atmosphere through a dry element type air cleaner into the first compression stage cylinder. As the first stage piston travels upward the intake valve closes allowing the air trapped in the cylinder to be compressed to a pressure of 55 ± 5 psig (379 ± 34.5 kPa). This air then passes through the first stage air cooler subassembly and the first stage trap which reduces the air temperature due to compression heat and removes oil and condensate prior to the air entering the second compression stage cylinder. As the second compression stage piston starts to travel downward, the pressure differential causes the second stage intake valve to open, admitting the air from the first stage air cooler subassembly into the second compressor stage cylinder. When the second stage piston starts to travel upward; the second stage intake valve closes, allowing the air trapped in the cylinder to be compressed to a pressure of 195 ± 10 psig (1344 ± 68.9 kPa). This air then passes through the second stage air cooler subassembly and second stage trap for cooling and removal of oil and condensate prior to the air entering the third stage compression cylinder. As the third compression stage piston starts to travel downward, the pressure differential causes the third stage intake valve to open admitting the air from the second stage air cooler subassembly. When the third stage piston starts to travel upward, the third stage intake valve closes, allowing the air trapped in the cylinder to be compressed to a pressure of 900 ± 50 psig (6201 ± 344.5 kPa). This air then passes through the third stage air cooler subassembly

and third stage trap for cooling and removal of oil and condensate prior to entering the fourth compression stage cylinder. As the fourth stage piston starts to travel downward, the pressure differential causes the fourth stage intake valve to open admitting the air from the third stage air cooler subassembly. When the fourth stage piston starts to travel upward, the fourth stage intake valve closes allowing the air trapped in the cylinder to be compressed to a pressure of $3,200 \pm 25$ psig ($22,048 \pm 172.3$ kPa). This air then passes through the fourth stage air cooler subassembly which reduces the temperature of the air. The air then passes through the mechanical filter where airborne foreign particles and moisture are removed. The partially clean air is then directed through the rupture disc (4,400 psi) to the first (No. 1) dehydrator then to the second (No. 2) dehydrator, where the air is thoroughly dried of condensate and oil.

4-4. Attached to dehydrator (Cyl. No. 2) is the priority valve which maintains correct pressure for proper circulation within the air purification cylinders. The priority valve is set to open at 2,300 psig (15,897 kPa). From the priority valve the air passes through the air purification cylinders before it flows through the ten micron filter where airborne particles larger than ten microns are removed.

4-5. A method of continuous removal of moisture collected in the first, second, and third stage traps is provided. Removing this moisture, as it is separated, allows the compressor to operate for an extended period of time without unloading. The air allowed to bleed-off will not appreciably reduce the pressure of the output service air, but it will result in a slight increase in the pressure of the first stage air. The first stage trap continuous bleed valve generates a one psi pressure differential across the valve orifice. This differential allows the bleed valve to crack, allowing a small amount of the moisture laden pressurized air to bleed off through the first stage trap filter and line strainer to the condensate receiver. As pressurized air from the second stage compression cylinder passes through the second stage trap it generates a pressure differential in the second stage trap continuous bleed valve, 195 ± 10 psig (1344 ± 68.9 kPa) downstream of the valve and 14.7 psi (101.3 kPa) upstream of the valve. The second stage continuous bleed valve will open, causing the first stage trap continuous bleed valve to open. This will allow a small amount of moisture laden, pressurized air to bleed off through the second stage trap filter, second stage line

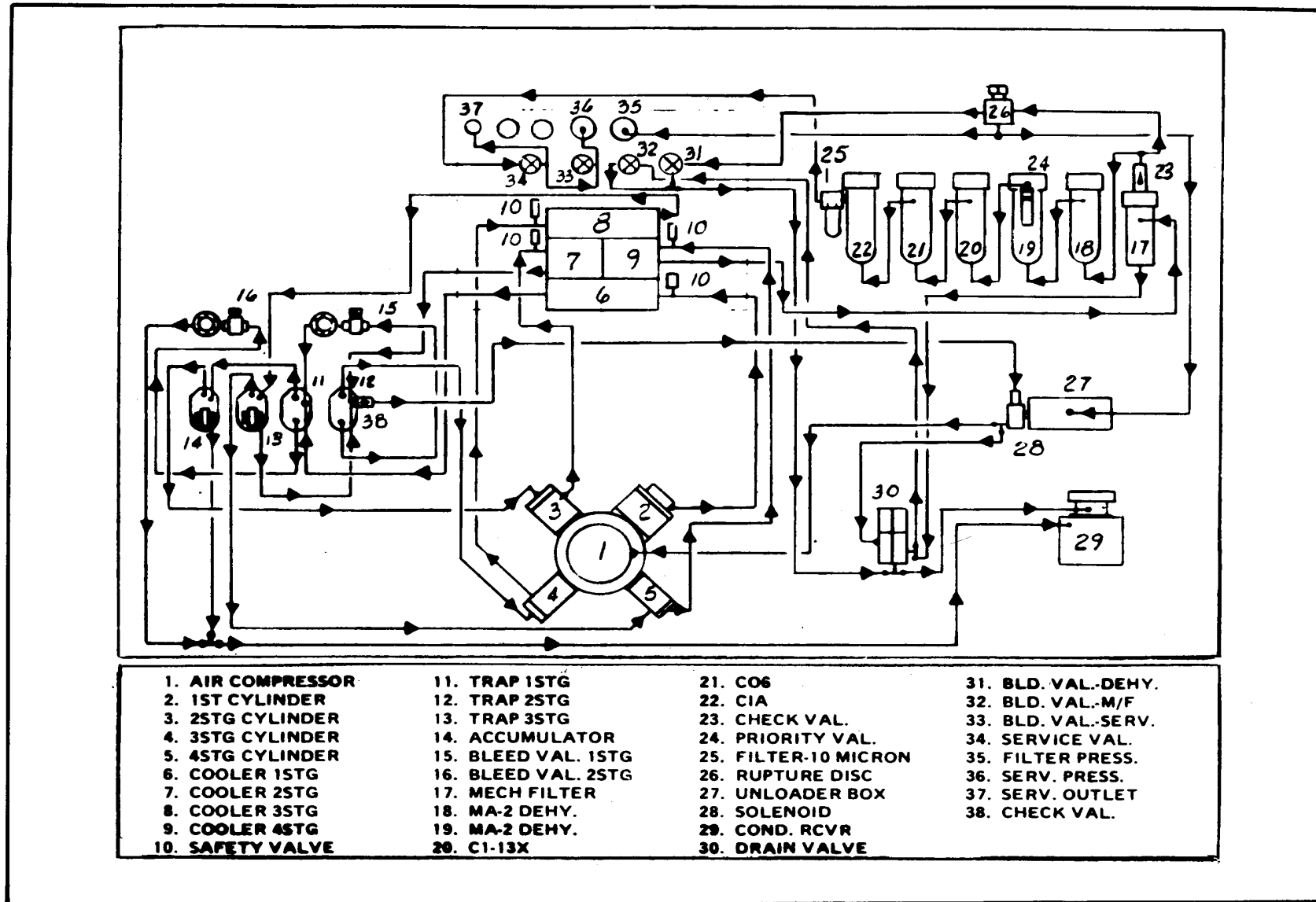

Figure 4-1. Air Flow Diagram

strainer, and through the first stage trap to the condensate receiver. When pressurized air from the third compression stage cylinder passes through the third stage trap it generates a pressure differential in the third stage trap continuous bleed valve, 900 ± 50 psig (6201 ± 344.5 kPa) downstream of the valve and 14.7 psi (101.3 kPa) upstream of the valve. The third stage continuous bleed valve will open, causing the first and second stage traps continuous bleed valves to open. This will allow a small amount of moisture laden pressurized air to bleed off through the third stage trap filter and line strainer through the first and second stage traps to the condensate receiver.

4-6. AUTOMATIC CONTROL AND DRAIN SYSTEM (See Figure 4-2). A constant speed type unloader is provided to automatically unload the compressor unit when the discharge pressure exceeds 3300 psi ± 175 psi and to load the compressor when discharge pressure drops approximately 300 psi below unload pressure. The compressor unit unloads automatically upon stopping so that the compressor will be unloaded at startup to decrease the starting load. Upon unloading, the mechanical filter (figure 5-6) is automatically drained of condensed moisture and oil. A manual compressor unload switch is provided on the instrument panel and a manual control for draining the mechanical filter. When pressure in the system reaches approximately 3300 ± 175 psi, the normally closed contacts of pressure switch (10, Figure 7-2) will open. The solenoid valve (10) is then deenergized allowing air to flow through the auto check valve from the second stage to automatic drain valve, which then opens. The air and condensate in the mechanical filter exhausts to atmosphere through the drain valve and into the condensate receiver. Condensate and a small amount of air is continuously passed from the third stage trap through line filter and continuous bleed valve. Likewise, condensate and small amount of air passes from second and first stage traps through line filters; through continuous bleed valves, and is exhausted through the condensate receiver (26). Condensate passing through the drain valve is collected in the condensate receiver when the compressor unloads, actuating the drain valve. Opening the dehydrator bleed valve (Figure 42), located on the control panel, will actuate the auto drain valve and exhaust condensate and air from the dehydrators and from the accumulator into the condensate receiver. The intake of the first stage is not closed and will continue to draw in air but will not compress as the air is allowed to escape through through the traps. When system air pressure drops to approximately 3000 psi, the pressure switch closes energizing solenoid valve (10, Figure 7-2) and exhausts the air from automatic drain valve. This allows the drain valve to close and air being drawn into the first stage is compressed and the compressing cycle begins again. A manual drain valve is provided on the condensate receiver for manually draining

the receiver of condensate moisture. The condensate receiver shall be drained after every eight (8) hours of operation or after compressor shut-down.

4-7. Engine oil pressure switch (12, Figure 7-2) is connected to the engine oil pressure system. Compressor assembly oil pressure switch (8) is connected to the compressor assembly oil pressure system. The engine oil pressure switch will open and cause the compressor to unload and engine to stop if oil pressure is lost while the engine is operating. Safety control relay (10) in the unloader control box is also deenergized if either oil pressure switch opens. When the COMPRESSOR UNLOADER switch (7) is in the UNLOAD position there is no current flow through solenoid valve (10) and the compressor is unloaded. When engine and compressor assembly oil pressure develop after engaging the clutch, the oil pressure switches close. Switch (7) is placed to the LOAD position energizing the solenoid valve coil (10). Current flows through the closed contacts of pressure switch (10), and the compressor unit will begin to load.

4-8. ELECTRICAL SYSTEM (Figure 7-2). The air compressor unit has a 12 volt dc negative ground electrical system. The electrical system consists of two primary circuits: starting and charging circuit and pilot control circuit. The starting and charging circuit starts the diesel engine assembly and charges battery (1) during air compressor unit operation. When MASTER SWITCH (5) is closed, pressing START SWITCH (4) completes the circuit path for starting motor (2). Voltage is applied from the positive terminal of (1) across closed contacts of (5) and (4), (2) solenoid and field coils of (2) to ground. Simultaneously, 12 volts dc is applied across AMMETER (6), UNLOAD position contacts of COMPRESSOR UNLOADER switch (7) and coil of safety relay (10). Relay (10) energizes causing fuel shutoff solenoid (13) to deenergize. This will shut off oil fuel from the engine's fuel pump to the injectors. Motor (2) will turn the engine crankshaft until the engine's oil pump develops eight psi oil pressure. At eight psig (55 kPa) engine oil pressure, engine oil pressure switch (12) will open deenergizing safety control relay (10). When (10) deenergizes, (13) will energize allowing the engine's fuel pump to deliver fuel to the injectors. This will cause the air and fuel mixture in the engine cylinders to ignite. Once the engine is running start switch (4) is released. Battery (1) is charged by alternator (3) with voltage regulator controlling the rate of charge. Electrical power for air compressor unit operation is now supplied by the alternator (2).

4-9. Hourmeter (16, Figure 7-2) monitors the running time of the air compressor unit under load conditions. When pressure in the system reaches approximately 3200 ± 100 psig (21984 kPa), pressure switch (10) is opened by

system air pressure. Solenoid valve coil (10) is deenergized, stopping the air compressor unit from loading. When system air pressure decreases to approximately 3000 psig (17225 kPa), (10) closes, energizing (10) and allowing the air compressor unit to load.

4-10. In the event that the engine should overheat, cylinder head temperature switch (11) will close. This will cause safety relay (10) to energize. When (10) energizes, fuel solenoid valve (13) deenergizes. Fuel flow to the engine ceases and the engine stops. If engine oil pressure should fall below 8 ± 1 psig (55 ± 7 kPa), switch (12) will close. This will cause safety relay (10) to energize. If compressor oil pressure should fall below 8 ± 1 psig (55 ± 7 kPa), switch (8) will open. With the LOAD/UNLOAD switch (7) in the LOAD position, unloader valve (10) will deenergize. When (10) deenergizes the air compressor unit will continue to operate but will not load the air receiver.

4-11. OPERATING CONTROLS AND INDICATORS. All controls and indicators necessary for operation of the air compressor unit are located either on the control panel or instrument panel. Name plates are provided to identify all controls and indicators. Identification and function of each control and indicator is as follows (see Figure 42).

4-12. HOURMETER (1, Figure 4-2). The hourmeter indicates the total number of hours that the compressor has been operated. A pressure switch closes the electrical circuit to the hourmeter when the compression cycle begins. Records of hourmeter indications will be used to initiate maintenance schedules for performing service and maintenance functions.

4-13. AMMETER (2, Figure 42). The ammeter indicates the output of the alternator which is used to charge the battery. Under normal operation, the ammeter will indicate a changing rate of the alternator varying from zero (0) to a plus (+) 40 amps.

4-14. COMPRESSOR OUTPUT INDICATOR (3, Figure 4-2). The COMPRESSOR OUTPUT INDICATOR will indicate the PSIG of the compressor output through the mechanical filter (18, Figure 8-2) immediately downstream from the 4th stage of the compressor.

4-15. SERVICE PRESSURE GAUGE (4, Figure 4-2). This gauge will give the PSIG pressure available at the compressor unit service outlet (7).

4-16. COMPRESSOR OIL PRESSURE GAUGE (5, Figure 4-2). The COMPRESSOR OIL PRESSURE gauge indicates air compressor lubricating oil pressure in pounds per square inch (PSI). Normal air compressor oil pressure is 25 ± 5 psi

(173 ± 35 kPa). If the compressor oil pressure should drop below $8 \text{ psi} + 1 \text{ psi}$ ($55 \text{ kPa} \pm 6.89 \text{ kPa}$) while operating, the compressor will shut down and the cause of low oil pressure should be determined. Refer to troubleshooting, Table 5-4.

4-17. ENGINE OIL PRESSURE GAUGE (6, Figure 4-2). The ENGINE OIL PRESSURE gauge indicates the oil pressure present in the engine lubricating system. Normal operating pressure range is 60 ± 10 psi (414 ± 689 kPa). If engine oil pressure should drop below 8 psi (55 kPa) while operating the engine will shut down.

4-18. SERVICE AIR OUTLET (7, Figure 4-2). The SERVICE AIR OUTLET is the primary outlet. A servicing hose is attached to the outlet and storage air tanks as needed.

4-19. START SWITCH (8, Figure 4-2). The diesel engine START SWITCH is a spring-loaded switch that controls the flow of the electrical current to the starting motor. When the START SWITCH is pressed it completes the circuit to the starting motor which in turn completes a path to ground for the battery allowing the starting motor to run. When the start switch is released, it returns to the off position stopping the starting motor.

4-20. MASTER SWITCH (9, Figure 4.2). The MASTER SWITCH is a disconnect switch for the air compressor unit's electrical system.

4-21. THROTTLE CONTROL (10, Figure 4-2). The ENGINE THROTTLE is connected to the engine governor, which controls the engine speed from idle to 2,000 rpm (2,000 r/min). Pulling the THROTTLE CONTROL out raises the engine speed. Turn THROTTLE CONTROL handle clockwise to hold and lock engine speed. Turning the handle counterclockwise unlocks the handle. Push handle in to reduce engine speed.

4-22. CLUTCH OPERATING ROD (11, Figure 4-3). The clutch which connects the diesel engine to the air compressor, is operated by the CLUTCH operating rod. The clutch is disengaged when the clutch handle is away from the instrument panel. Push clutch rod handle toward instrument panel to engage the clutch.

4-23. SERVICE VALVE (12, Figure 4-2). The SERVICE VALVE controls the flow of breathable air through the SERVICE OUTLET (7). The SERVICE VALVE (1 2) should be fully open when a receiving unit is being charged, and closed when the compressor is building up its working pressure.

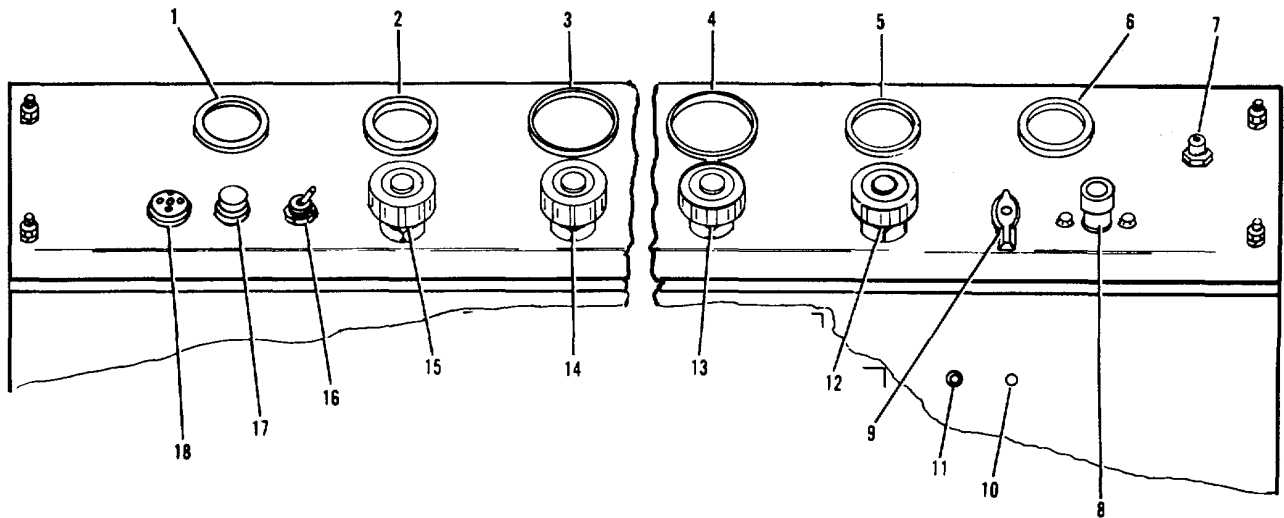

- | | |
|---|-----------------------------------|
| 1. HOURMETER | 11. CLUTCH ROD |
| 2. AMMETER | 12. SERVICE VALVE |
| 3. COMPRESSOR OUTPUT PRESSURE (TO MECH. FILTER) | 13. SERVICE HOSE BLEED VALVE |
| 4. SERVICE PRESSURE GAUGE | 14. MECHANICAL FILTER DRAIN |
| 5. COMPRESSOR OIL PRESSURE GAUGE | 15. DEHYDRATOR BLEED VALVE |
| 6. ENGINE OIL PRESSURE GAUGE | 16. COMPRESSOR LOAD/UNLOAD SWITCH |
| 7. SERVICE OUTLET | 17. PUSHBUTTON GLO-PLUG |
| 8. START SWITCH | 18. INDICATOR, GLO-PLUG |
| 9. MASTER SWITCH | 19. EXTRA FUEL BUTTON |
| 10. ENGINE THROTTLE CONTROL | 20. HAND PRIMER |

Figure 4-2. Operating Controls and Indicators

4-24. SERVICE HOSE BLEED VALVE (13, Figure 4-3). The SERVICE HOSE BLEED VALVE relieves all air pressure from the Service Hose. Opening the valve, by turning counterclockwise, will vent the air in the service hose to atmosphere.

4-25. MECHANICAL FILTER DRAIN VALVE (14, Figure 4-3). The MECHANICAL FILTER DRAIN VALVE relieves all air pressure from the air compressor through the mechanical filter. Opening the valve, by turning counterclockwise, will vent the air to atmosphere.

4-26. DEHYDRATOR BLEED VALVE (15, Figure 4-3). The DEHYDRATOR BLEED VALVE relieves all air pressure from the mechanical filter through to the service outlet. Opening the valve, by turning counterclockwise, will vent the air in this line to atmosphere.

4-27. COMPRESSOR UNLOADER SWITCH (16, Figure 4-3). The COMPRESSOR UNLOADER toggle switch serves two functions. When placed in the UNLOAD position the compressor oil pressure switch is bypassed, enabling the engine to be started. Since no current passes through the normally open solenoid valve, the compressor can be started unloaded. When compressor oil pressure develops after engaging the clutch, the UNLOADER SWITCH is placed in the LOAD position and the compressor begins to load.

4-28. PUSHBUTTON GLO-PLUG SWITCH (17, Figure 4-4-3). The PUSHBUTTON GLO-PLUG switch is pressed to energize the glow plug in the engine's air intake when ambient air is minus ⁵⁰F (-150C) or below. This will preheat the intake air prior to the air entering the combustion chambers.

4-29 INDICATOR GLO-PLUG (18, Figure 4-3). The INDICATOR GLO-PLUG (13) is connected in series with the glo plug in the engine air intake. When the PUSH-BUTTON GLO-PLUG is pressed the INDICATOR GLO-PLUG (17) will heat-up and glow red to indicate that the glow plug is operating.

4-30. Air Cooler Doors (19, Figure 4-3). The air cooler doors (26 and 30) control the amount of air being drawn through the air cooler by the fan. The doors may be adjusted by closing, opening, and sliding to either side for cold weather operation.

4-31. EXTRA FUEL BUTTON (20, Figure 4-3). By pulling and releasing the extra fuel button, extra fuel is injected into the engine for easier starting in cold weather.

4-32. OPERATION INSTRUCTIONS.

4-33. PRIOR TO OPERATION. Prior to operation of the air compressor unit, perform the following procedure:

CAUTION

The unit should be located in an area as free of dust and dirt as possible. A highly contaminated atmosphere places abnormal load on the air cleaners, oil filters, dehydrators, and compressor, which can result in increased maintenance.

a. Transport the unit to work site and select a location as nearly level as possible. Out-of-level shall not exceed 150 in any direction.

b. Perform all inspection, checks, and services, as required, refer to table 5-2.

c. Open air cooler doors.

WARNING

Under no circumstances should the air purification cartridges in cylinders No. 3, 4 and 5 (23, 24, 25, Figure 8-2) be allowed to become contaminated with moisture. If in doubt, change the cartridges.

NOTE

When dehydrator and air purification cartridges are changed, make certain to record hourmeter readings. Approximate time elapse for cartridge change is as follows. Actual frequency of cartridge change depends on governing weather conditions at a given time or place:

Dehydrators: Approximate hours

Cylinders 1 and 2 8 hrs.

Air purification
Cylinders

Cylinders 3, 4, & 5 96 hrs.

d. Check the number of hours that the cartridges in the dehydrators and filters have been used. This is done by comparing the time of their installation with the HOUR-METER (1, Figure 4-2) indication. If the next period of

operation will exceed the remaining useful life of the cartridges, replace the cartridges as per paragraph 5-7.

WARNING

Observe wind direction, make sure compressor air breather hose is upwind of engine exhaust so that no exhaust gasses are introduced into the compressor unit.

e. Uncoil and lay out compressor intake air hose in the opposite direction from the way the engine exhaust gasses will move, so that contaminated air is not introduced into the compressor unit.

WARNING

Never attempt to fill the fuel tank while the engine is operating or hot. A spark occurring could cause an explosion or fire. Do not operate the unit in a building or an enclosed area unless exhaust gases are piped outside. Inhalation of exhaust gases can cause serious illness or death.

f. Before initially starting the diesel engine, or if the engine has been out of operation for some time, the hand primer (20, Figure 4-2) on the fuel supply pump should be used to pump fuel into the fuel system. When priming, a distinct resistance to the primer pump should be felt when moving the hand primer lever up and down. Pump the hand primer five or six times.

4-34. CONNECTION BETWEEN AIR COMPRESSOR UNIT AND BREATHABLE AIR SYSTEM TO BE CHARGED. A high pressure service outlet (7, Figure 4-2) is provided to charge scuba service tanks with up to 3200 psi (22,048 kPa) of breathable air.

4-35. CONNECTION BETWEEN AIR COMPRESSOR UNIT AND BREATHABLE SYSTEM TO BE CHARGED. A high pressure air service hose should be used to charge breathable air systems. The air service hose is equipped with a high pressure air chuck. The chuck should be connected to the valve fitting of the item to be charged. To charge a system, proceed as follows:

WARNING

Never connect the air service hose to a pneumatic system without first making certain that HIGH PRESSURE SERVICE valve is closed and the HIGH PRESSURE SERVICE gauge indicates zero psi. Never disconnect the air

service hose after charging a system without making certain that the service valve is closed, and the SERVICE HOSE BLEED valve is open to relieve all air pressure in the air service hose.

CAUTION

The stems and seats of the control panel valves may be damaged by overtightening. All valves should be tightened only enough to prevent leakage.

a. Close all control valves on the control panel.

b. Connect service hose to breathable air service connector as required.

CAUTION

When ambient air temperature is 32°F (0°C) or above keep air cooler doors open during air compressor unit operation. Below 32°F (0°C) ambient, keep air cooler doors closed during air compressor unit operation.

4-36. STARTING UNDER NORMAL CONDITIONS, ABOVE 32°F (0°C). Perform the Prior To Operation Procedures (Section IV). Make the necessary connections described in CONNECTION BETWEEN AIR COMPRESSOR UNIT (Section IV) and BREATHABLE AIR SYSTEM TO BE CHARGED. Proceed as follows:

a. Make certain CLUTCH handle (11, Figure 4-3) is in disengaged position, away from control panel.

b. Make certain COMPRESSOR UNLOADER switch (16, Figure 4-3) is in the UNLOAD position and close all control panel valves.

c. Make certain ENGINE THROTTLE CONTROL (10), is positioned half way in (idle position 1,100 ± 100 rpm [1,100 ± 100 r/min]).

d. Turn MASTER SWITCH (9) to 45° cw position.

CAUTION

If engine oil pressure does not register on gauge within five seconds, shut down engine and determine cause. Refer to Troubleshooting (Section V).

e. Push engine START switch (8). When engine starts continue to hold START switch until ENGINE OIL PRESSURE gauge (6) registers pressure; then, release START switch.

f. After engine is running allow engine to warm up a minimum of 5 minutes at $1,100 \pm 100$ rpm ($1,100 \pm 100$ r/min). During warm-up do not allow engine speed to exceed 1,400 rpm (1,400 r/min). This will avoid clutch plate drag.

CAUTION

If compressor oil pressure does not register within 5 seconds, shut down engine, and determine cause. Refer to TROUBLESHOOTING, (Section V).

g. After engine is warm, engage clutch by pushing clutch handle toward panel with a hard fast thrust. COMPRESSOR OIL PRESSURE gauge (5) should indicate oil pressure within five seconds.

h. Pull engine THROTTLE CONTROL to the full out position and lock by turning handle in clockwise direction until snug.

WARNING

Compressed air is dangerous. Make certain that service hoses to be used are not frayed, cracked, or deteriorated in any way.

4-37. STARTING UNDER COLD CONDITIONS (5°F to 32°F) (-18°C to 0°C).

a. If ambient temperature is between 5°F (-18°C) and 32°F (0°C), press and hold PUSHBUTTON GLO-PLUG switch (17) until heating coil glows red. Do not hold longer than one minute.

b. Make certain CLUTCH handle (11) is in disengaged position, away from control panel.

c. Make certain COMPRESSOR UNLOADER switch (16) is in the UNLOAD position and close all control panel valves.

d. Make certain ENGINE THROTTLE CONTROL (11) is positioned half way in (idle position $1,100 \pm 100$ rpm [$1,100 \pm 100$ r/min]).

e. Turn MASTER SWITCH (9) to 45° cw position.

CAUTION

If engine oil pressure does not register on gauge within five seconds, shut down engine and determine cause. Refer to Troubleshooting (Section V).

f. Push engine START switch (8). When engine starts continue to hold START switch until ENGINE OIL PRESSURE gauge (6) registers pressure; then, release START switch.

g. After engine is running, allow engine to warm up a minimum of 5 minutes at $1,100 \pm 100$ rpm ($1,100 \pm 100$ r/min). During warm-up do not allow engine speed to exceed 1,400 rpm (1,400 r/min). This will avoid clutch plate drag.

CAUTION

If compressor oil pressure does not register within 5 seconds, shut down engine, and determine cause. Refer to TROUBLESHOOTING, (Section V).

h. After engine is warm, engage clutch by pushing clutch handle toward panel with a hard fast thrust. COMPRESSOR OIL PRESSURE gauge (5) should indicate oil pressure within five seconds.

i. Pull engine THROTTLE CONTROL to the full out position and lock by turning handle in clockwise direction until snug.

WARNING

Compressed air is dangerous. Make certain that service hoses to be used are not frayed, cracked, or deteriorated in any way.

4-38. STARTING UNDER EXTREME COLD CONDITIONS, BELOW 5°F (-15°C). To start the air compressor unit under extreme cold conditions, proceed as follows:

a. The air compressor unit shall be preheated before operating in temperatures below 5°F (15°C).

b. A steady flow of heated air should be directed at the engine and air compressor for a minimum period of 30 min. prior to starting the engine.

c. Refer to para. 437 b. through i.

4-39. STOPPING PROCEDURE. After charging operation is completed, proceed as follows:

a. Place the COMPRESSOR UNLOADER (16, Figure 4-2) switch to the UNLOAD position.

b. Unlock and push ENGINE THROTTLE CONTROL (10) to the idle position. Disengage clutch by pulling CLUTCH handle (1) away from control panel.

c. Allow engine to run without a load at a maximum speed of 1,400 rpm (1,400 r/min) for approximately five minutes.

d. Push ENGINE THROTTLE CONTROL (10) completely in.

e. Place the MASTER SWITCH (9) 45° ccw to off position.

f. To drain the air from the air compressor unit, open the service hose bleed valve (13), mechanical filter drain

valve (14), and the dehydrator bleed valve (15). When all air pressure is relieved, observe pressure gauges and close all valves.

g. If attached, disconnect and stow service hose. Drain condensate receiver (23, Figure 1-1).

4-40. EMERGENCY STOPPING PROCEDURE. In case of emergency that would require immediate stopping of the air compressor unit, place the MASTER SWITCH (9, Figure 4-2) to the off position.

4-9/(4-10 Blank)

SECTION V.

MAINTENANCE INSTRUCTIONS

5-1. GENERAL. This section contains organizational and intermediate maintenance instructions for the air compressor unit.

5-2. OPERATIONAL CHECKOUT. Operational checkout of the air compressor unit consists of operating the unit and observing instrument panel meter and gauge indications. Correct instrument panel meter and gauge indications are listed in Table 5- 1. To perform operational checkout, proceed as follows:

a. Make certain CLUTCH operating rod (11, Figure 4-2) is in disengaged position, away from control panel.

b. Make certain COMPRESSOR UNLOADER switch (16) is in the UNLOAD position and close all control panel valves.

c. Make certain ENGINE THROTTLE control (10), is positioned half way in (idle position $1,100 \pm 100$ rpm [$1,100 \pm 100$ r/min]).

d. Turn MASTER SWITCH (9) to 45° cw position.

CAUTION

If engine oil pressure does not register on gauge within five seconds, immediately shut down engine and determine cause. Refer to Troubleshooting (Section V).

e. Push engine START switch (8). When engine starts continue to hold START switch until ENGINE OIL PRES-

SURE gauge (6) registers pressure; then, release START switch.

f. After engine is running, allow engine to warm up a minimum of 5 minutes at $1,100 \pm 100$ rpm ($1,100 \pm 100$ r/min).

g. After engine is warm, engage clutch by pushing clutch handle toward panel with a hard fast thrust.

CAUTION

If compressor oil pressure does not register within 5 seconds, shut down engine, and determine cause. Refer to TROUBLESHOOTING (Section V).

h. Pull engine THROTTLE CONTROL to the full out position and lock by turning handle in clockwise direction until snug. COMPRESSOR OIL PRESSURE GAUGE (5) should register oil pressure within five seconds.

WARNING

Make certain all control valves on control panel are closed.

i. Place COMPRESSOR UNLOADER switch to LOAD position. This function allows the compressor to furnish breathable air to the receiver @ 3200 psi.

j. Observe high pressure gauge (4) indication. With air compressor unit operating under normal conditions,

Table 5-1. Instrument Panel Meter and Gauge Indication

METER OR GAUGE	INDICATION
AIR SERVICE PRESSURE	3200 psi (22,048 kPa)
4TH STAGE PRESSURE @ MECHANICAL FILTER	3200 ± 25 psi ($22,048 \pm 170$ kPa)
COMPRESSOR OIL PRESSURE	25 ± 5 psi (172 ± 35 kPa)
ENGINE OIL PRESSURE	60 ± 10 psi ($413 \pm (0.9$ kPa)
AMMETER	2 + 38 AMPERES

compressor unit should load at a minimum pressure of 2,300 psig (1 5847 kPa). Air compressor unit should unload at a maximum pressure of 3,300 ± 50 psig (22,392 kPa). If air compressor loads or unloads at an incorrect pressure, refer to PRESSURE SWITCH ADJUSTMENT (Section V).

k. Push ENGINE THROTTLE CONTROL to the idle position. Disengage clutch by pulling CLUTCH operating rod away from control panel.

l. Allow engine to run without a load at a maximum speed of 1,400 rpm (1,400 r/min) for approximately five minutes.

m. Push ENGINE THROTTLE CONTROL completely in. Turn MASTER SWITCH 45° ccw.

n. To drain the air from the air compressor system, open the DEHYDRATOR BLEED VALVE, mechanical filter drain valve (11), and service hose bleed valve (13).

5-3. Pressure Switch Adjustment (Figure 5-1). The pressure switch is located in the unloader control box (Figure 1-1). Unfasten and raise cover of control box. To adjust pressure switch actuating point, proceed as follows:

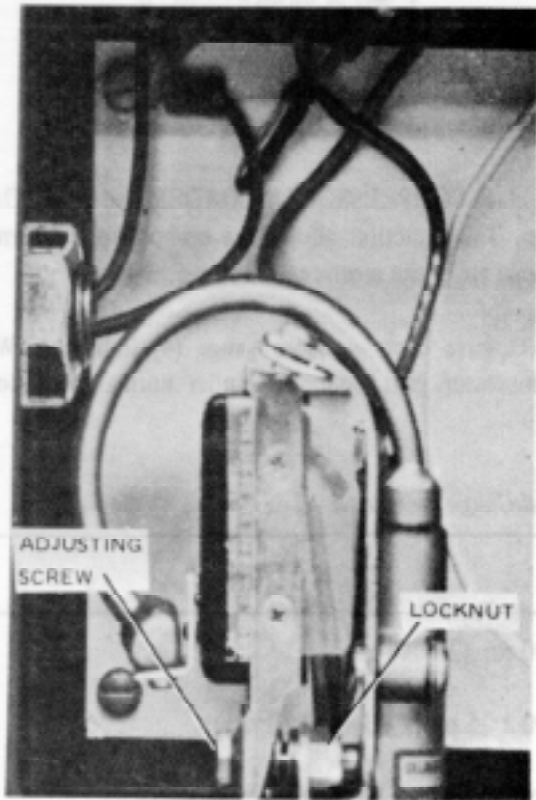

Figure 5-1. Pressure Switch Adjustment

a. Observe compressor pressure gauge indication when compressor unloads. The air compressor unit should unload at 3300 ± 100 psi (22,757 ± 689 kPa).

b. Using an open end wrench, or offset screwdriver, turn adjusting screw clockwise to decrease switch actuating pressure and counterclockwise to increase switch actuating pressure.

c. Observe service pressure gauge (4) indication. With air compressor unit operating under normal conditions, compressor unit should load at a minimum pressure of 3,000 psi (20,670 kPa). The air compressor unit should unload at a maximum pressure of 3300 psi ± 50 psi.

5-4. INSPECTION AND PREVENTIVE MAINTENANCE.

Preventive maintenance checks, services, and inspection are listed in Table 5-2. Detailed procedures are contained in following paragraphs. The table lists the service time in intervals of operating hours. If a check, service, or inspection procedure should be accomplished at an interval other than operating hours, the time interval is listed in the service column.

5-5. Air Compressor Air Filter (Figure 5-2). The compressor air cleaner is a dry, replaceable element type. Service the air cleaner as follows:

a. Unscrew the winged nut on the top assembly. Remove the top cover and filter element.

b. If inside of filter can is dirty, clean with lint free cloth.

c. Install cleaned or new element on filter can base, install filter cover, with the air inlet hole pointing away from the compressor. Screw wing nut down finger tight.

5-6. Engine Air Filter (Figure 5-3). The engine air filter is an oil bath type. Service the air filter as follows:

a. Remove supporting band front air cleaner.

b. Unfasten and remove oil container from air filter housing.

c. If oil is dirty, dump oil and dirt from container.

d. Clean container with a lint-free cloth using a hot water and detergent solution per Federal Specification, P-D-220. Allow oil container to air dry.

Table 5-2. Inspection, Checks, and Services

COMPONENT OR PART	INSPECTION, CHECK, OR SERVICE	OPERATIONAL TIME PERIOD
COMPRESSOR UN-LOADER switch and the DEHYDRATOR BLEED valve	If the compressor has not been stopped or has not unloaded automatically, place the COMPRESSOR UNLOADER switch to the UNLOAD position. Open the DEHYDRATOR BLEED valve.	As necessary.
Entire unit	Visually inspect for loose or missing hardware	Before each use.
Engine crankcase	Check oil level and add oil if necessary to bring oil level to full mark. Refer to Table 5-3	Before each use and 4 hours.
Fuel tank	Check fuel level gauge. Fill tank as necessary. Refer to Table 1-2. Check vent holes in filler cap	Before each use and 8 hours.
Condensate receiver drain	Open drain cock to drain off condensate. Close drain valve	Before each use and 8 hours
Compressor crankcase	Check oil level and add oil if necessary to bring oil level to full mark. Refer to Table 5-3	Before each use and 8 hours.
Dehydrators	Check recorded HOURMETER indication of previous change and change cartridges as necessary, refer to DEHYDRATORS (Section V) and Purification Cylinders (Section V).	Before each use.
Engine air filter	Check for dirty oil if operating unit is in a very dusty location	Daily or 8 hours.
	Clean, service or replace as necessary, refer to ENGINE AIR FILTER (Section V).	
Compressor air filter	Check for dirty element if operating unit is in a very dusty Location. Clean, service or replace as necessary, refer to COMPRESSOR AIR FILTER (Section V).	150 hours or 6 months.
	Check for dirty element if operating unit is in extreme heat, dusty, or sandy areas. Clean, service or replace as necessary, refer to COMPRESSOR AIR FILTER (Section V).	80 hours or 30 days.
Compressor air filter hose screen	Check for clogged or stopped up holes in screen. Clean as necessary.	Before each use and 4 hours.
Battery	Check electrolyte level and fill to proper level with water if necessary. Check specific gravity of electrolyte.	150 hours or 6 months.
Engine fuel filter element	Replace filter element, refer to ENGINE FUEL FILTER ELEMENT (Section V).	150 hours or 6 months, as required

Table 5-2. Inspection, Checks, and Services - Continued

COMPONENT OR PART	INSPECTION, CHECK, OR SERVICE	OPERATIONAL TIME PERIOD
Mechanical filter	Replace element as necessary, refer to MECHANICAL FILTER (Section V). During operation in extreme heat, dusty, or sandy areas, replace element as necessary. Refer to MECHANICAL FILTER (Section V).	150 hours or 6 months. 80 hours or 30 days.
Air filter 10 micron)	Replace element as necessary, refer to TEN-MICRON FILTER (Section V). During operation in extreme heat, dusty, or sandy areas, replace element as necessary. Refer to TEN-MICRON FILTER (Section V).	150 hours or 6 months. 80 hours or 30 days.
Air purification filter	Replace element as necessary, refer to PRIOR TO OPERATION (Section IV, para. 4-33) and AIR PURIFICATION FILTER (Section V).	
Electric wiring and battery cables	Inspect for loose connections, damage, and corrosion. Tighten, replace, or clean as necessary.	150 hours or 6 months.
Trap filters	Clean filters, replace if damaged. Refer to FIRST, SECOND, AND THIRD STAGE TRAPS (Section V).	150 hours or 6 months.
Line strainers	Clean screens and elements, replace if damaged. Refer to LINE STRAINERS (Section V).	150 hours or 6 months.
Fuel tank	Check vent holes in filler cap.	150 hours or 6 months.
All air hose and tubing	Inspect entire air system for leaking or cracked connections and for hose/tube chaffing conditions.	Daily.
Clutch	Check clutch for proper engagement and adjust as necessary, refer to CLUTCH ADJUSTING YOKE ADJUSTMENT (Section V) and CLUTCH OPERATING ROD ADJUSTMENT (Section V).	150 hours or 6 months.
Air cooler assembly	Clean air cooler assembly fins as necessary. Refer to AIR COOLER SUBASSEMBLY (Section V).	150 hours or 6 months.
Engine cooling ribs and blower	Clean ribs and blower, refer to ENGINE COOLING RIBS AND BLOWER (Section V).	150 hours or 6 months.
Compressor crankcase filter	Clean crankcase filter, refer to COMPRESSOR CRANKCASE FILTER (Section V).	150 hours or 6 months.
Engine crankcase breather sieve	Clean sieve, refer to ENGINE CRANKCASE SIEVE (Section V).	150 hours or 6 months.
Engine tappet clearance	Check clearance and adjust as necessary, refer to ENGINE TAPPET CLEARANCE ADJUSTMENT (Section V).	150 hours or 6 months.

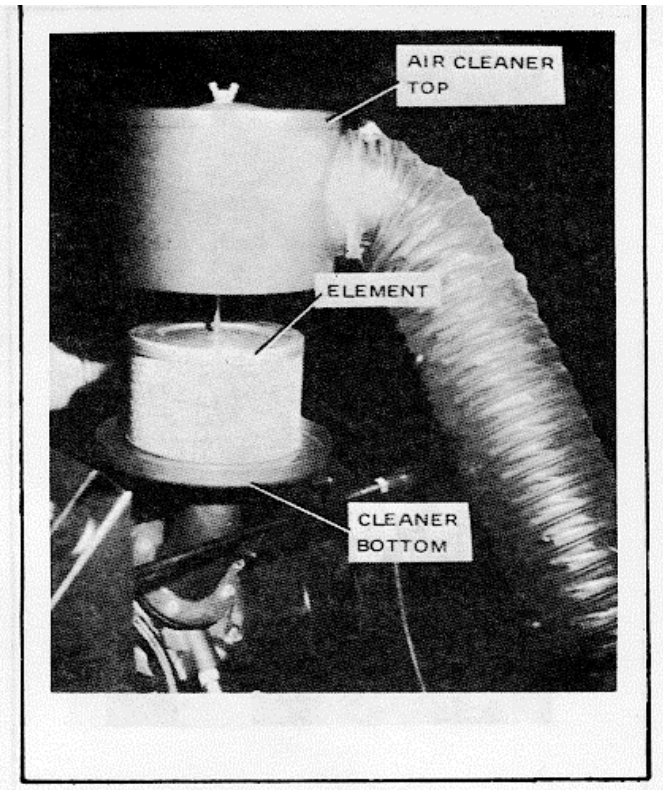

Figure 5-2. Air Compressor Air Filter

e. Care should be taken when either cleaning or assembling oil pan so that the seal is not harmed.

f. Clean mesh in filter using a hot water and detergent solution per Federal Specification P-D-220. Allow mesh to air dry.

g. Fill oil container to mark with clean engine oil. Refer to LUBRICATION (Section V) and Table 5-3. Install oil container on air filter housing.

h. Remove rain cap from air intake and clean dirt from air intake tube. Replace rain cap.

5-7. Dehydrators and Air Purification Cylinders. (See Figure 5-4 and Figure 8-2). The cartridges and filter elements shall be changed in accordance with the number of recorded operating hours. (See Table 5-2.) To change the cartridges on cylinders, proceed as follows:

WARNING

Make certain that all air pressure has been relieved from the compressor air supply system by opening the SERVICE HOSE

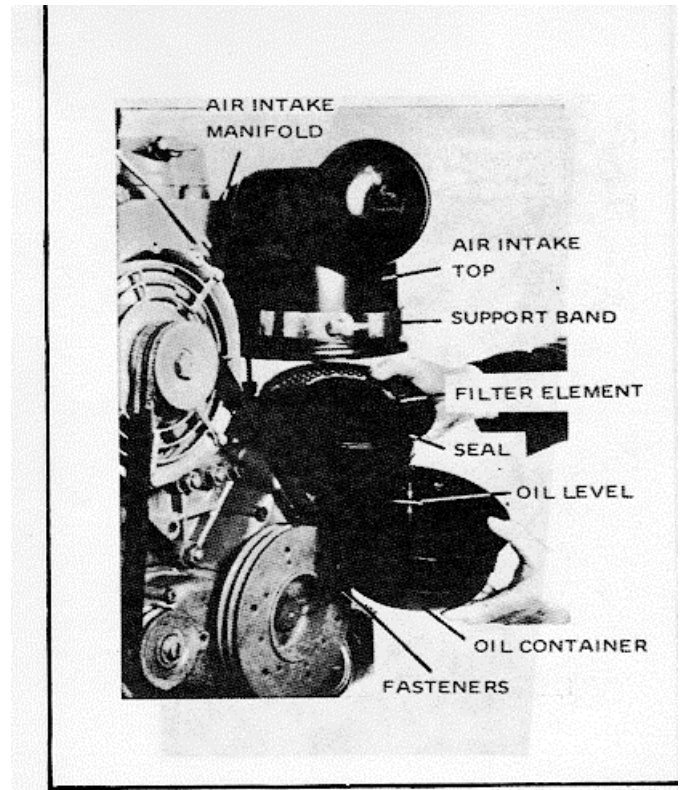

Figure 5-3. Engine Air Filter

BLEED VALVE, DEHYDRATOR BLEED VALVE and MECHANICAL FILTER DRAIN VALVE.

a. Using a strap wrench, unscrew cylinder caps from either dehydrators or air purifications cylinders.

CAUTION

Do not interchange cartridges/filters between cylinders, or reuse cartridges/filters.

b. Remove cartridges from cylinders, thoroughly clean the inside of the cylinders with a lint free cloth using hot water and detergent solution per Federal Specification P-D-220. Allow cylinder to air dry.

c. Examine o-rings in the cylinder caps and replace if damaged. Use AN6227B-35 or AN6227B-36 o-rings.

d. Remove and discard cartridges in dehydrator cylinders.

f. Place fresh type MA-2 cartridge in both dehydrator cylinders (cylinders 1 and 2) (see Figure 5-4 and Figure 8-2).

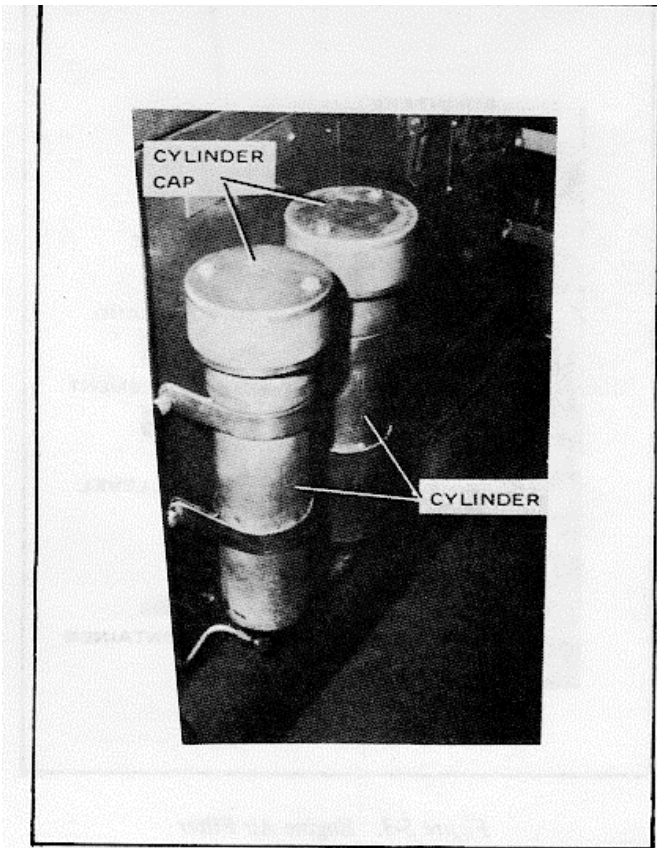

Figure 5-4. Dehydrators

g. Place fresh cartridges/filters in the air purification cylinders as follows (see Figure 8-2).

Cylinder	Cartridge
3	C-1-13X
4	C0-6
5	C-1-AC

CAUTION

Screw the cap assembly until snugly in place.

h. Screw cylinder caps back onto the cylinders. Apply enough force to cap assemblies to pierce the cartridges with the built-in piercing blades. After piercing blades have entered the cartridge, screw cap assembly down firmly against the cylinder. Do Not overtighten.

NOTE

Each time cartridges or filter are installed

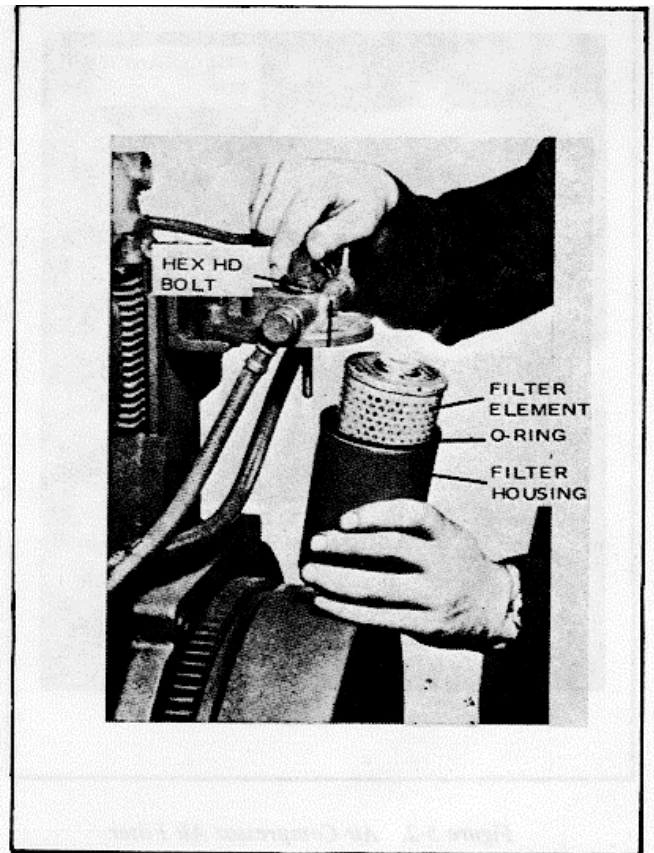

Figure 5-5. Engine Fuel Filter

record hourmeter readings on applicable forms.

5-8. Battery. To check the battery's state of charge, proceed as follows:

WARNING

Wear goggles to prevent electrolyte from coming into contact with eyes. To prevent serious burns wear rubber gloves and apron when filling battery.

a. To top up the battery, ordinary tap water may be used except in areas known to have a high mineral or alkali content in the water. In these areas, distilled water shall be used.

b. The fluid level should be maintained at the till to ring mark.

NOTE

If water is added during freezing weather, operate air compressor unit for several minutes afterward to mix water and battery electrolyte. If water is needed frequently, check for a cracked battery case or a faulty voltage regulator or alternator.

- c. Check battery's state of charge with a hydrometer. A fully-charged battery should have a hydrometer indication of $1.237 + 0.062$ specific gravity at 80°F (26°C) electrolyte temperature.

NOTE

To correct hydrometer indications for temperature variations, add 0.004 to the hydrometer indication for every 10°F (12 C); that the electrolyte is above 80°F (26°C); subtract 0.004 for every 10°F (12°C) below 80°F (26°C) electrolyte temperature.

- d. The indications obtained in all six cells should be nearly equal. If any cell is markedly lower, it is defective. If this low indication is not improved by charging, the battery should be replaced, particularly during cold weather.

NOTE

When charging a weak or sulphated (brownish color of electrolyte) battery, the slow charging method must be used. Never allow electrolyte temperature to exceed 120°F (48°C) during charging.

- c. Inspect the battery terminals for a tight fit on the posts and check for corrosion. Remove any deposits with a wire brush and coat the terminals, after placing them on the posts, with technical petrolatum, per Federal Specification VV-P-236 to prevent further corrosion.
- f. Check the battery case for cracks or leakage.

5-9. Engine Fuel Filter Element (Figure 5-5). To change the engine's fuel filter element, proceed as follows:

- a. Using a 13 mm wrench, unscrew and remove bolt and gasket attaching filter housing to flange.
- b. Using element d-ring, pull element from housing.

- c. Drain fuel and sediment from housing.

WARNING

Provide adequate ventilation when using P-D-680, Type II. Avoid prolonged breathing of vapors and minimize skin contact.

- d. Clean housing with a lint free cloth using solvent per Federal Specification P-D-680, Type 11. Allow housing to air dry.
- e. Clean mating surface of flange. Inspect flange o-ring. If o-ring is damaged, replace o-ring with a new one.
- f. Coat flange o-ring and element gaskets with engine fuel.
- g. Install new element over stem in housing with d-ring in the down position.
- h. Assemble housing, with element, to flange using gasket and bolt.

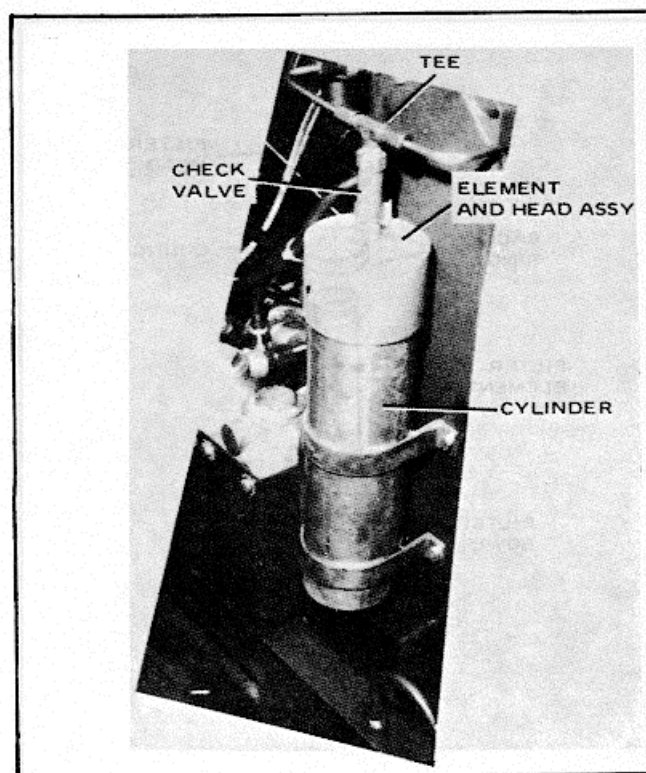

Figure 5-6. Mechanical Filter

5-10. Mechanical Filter (Figure 5-6). To change the mechanical filter's head and element proceed as follows:

WARNING

Make certain that all air pressure has been relieved from the compressor air supply system by opening the mechanical filter drain valve, dehydrator bleed valve and service hose bleed valve.

- a. Disconnect mechanical filter-to-dehydrator number one tube assembly at tee on mechanical filter.
- b. Unscrew nipple from mechanical filter. Remove nipple, check valve, and elbow, as an assembly from mechanical filter.
- c. Place a short bar or similar tool between the head studs for leverage and unscrew the head and element from cylinder.
- d. Thoroughly clean the inside of the cylinder, using a lint free cloth and a hot water and detergent solution per Federal Specification P-D-220. Allow cylinder to air dry.

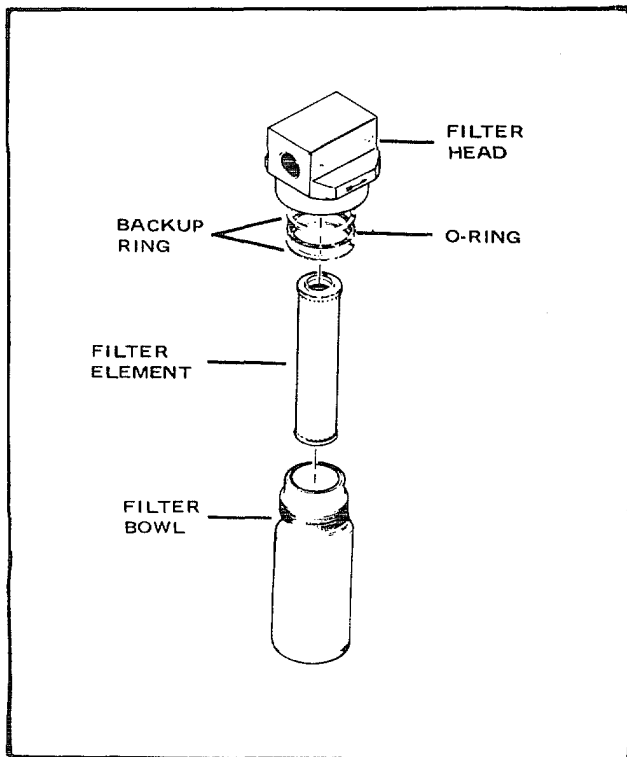

Figure 5-7. Ten Micron Air Filter

CAUTION

When installing new element, make certain that the head is started into cylinder squarely so that o-ring, supplied with the new element, is not damaged.

- e. Discard head and element and install a new head and element.

CAUTION

Screw the element into cylinder for a firm fit only. Sealing is accomplished by the o-ring seal, not by tightening. The leverage bar is used only as a wrench.

- f. Screw the element and head firmly into cylinder.

CAUTION

When installing pipe fittings in high pressure points in the system, use antiseize tape, MIL-T-27730, or equivalent on threads. Use only one wrap of the tape and do not overlap ends. Wrap back from fitting end approximately two threads to prevent cut bits of tape from entering the air system which will plug filters or small orifice holes within the system.

- g. Remove old antiseize tape from elbow and nipple. Wrap elbow and nipple with antiseize tape, per Military specification MIL-T-27730.
- h. Screw nipple, check valve, and elbow, as an assembly, into filter head.
- i. Reconnect mechanical filter-to-dehydrator number one tube assembly to elbow.

5-11. Ten-Micron Filter (Figure 5-7). To change the ten micron filter's element, proceed as follows:

WARNING

Make certain that all air pressure has been relieved from the compressor air supply system by opening the mechanical filter main valve, dehydrator bleed valve and service hose bleed valve.

- a. Unscrew the filter bowl from the head. If required, use a wrench on the square boss located on the bottom of the filter bowl.
- b. Remove the element assembly from the filter head, discard element and replace with an AN6235-2A type element assembly.



Tighten the filter bowl in the head, hand tight only. Sealing is accomplished by the o-ring seal, not by tightening.

- c. Check o-ring and backup rings for deterioration, cuts, or other damage. Replace as necessary.
- d. Make certain the new element assembly is seated properly in the filter head and screw the bowl in the filter head. Do not overtighten.

5-12. First, Second, and Third Stage Traps (Figure 5-8). To inspect and clean the first, second, and third stage trap filters, proceed as follows:

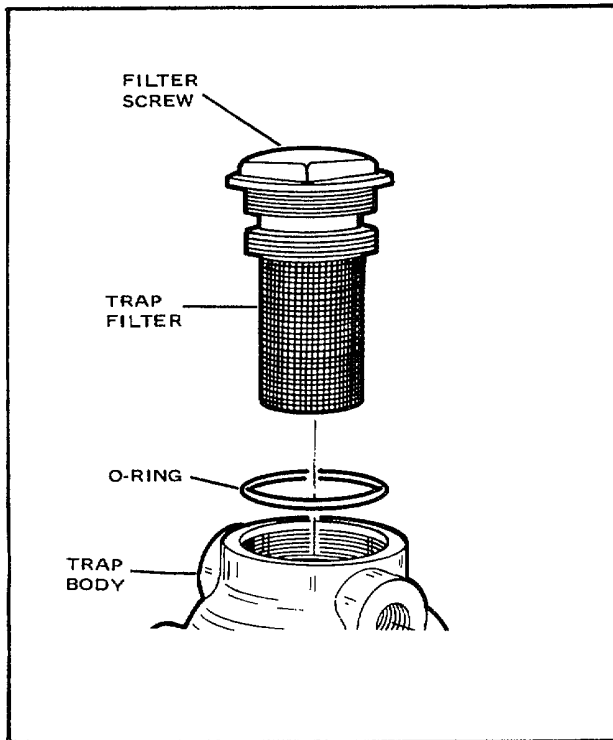

Figure 5-8. First, Second, and Third Stage Traps.



Make certain that all air pressure has been relieved from the compressor air supply system by opening the mechanical filter drain valve, dehydrator bleed valve, and service hose bleed valve.

- a. With compressor stopped and unloaded, unscrew and remove the trap filter assembly and o-ring from the top of the trap body. Remove the o-ring.



Provide adequate ventilation when using dry cleaning solvent (Federal Specification P-D- 680, Type II). Avoid prolonged breathing of vapors and minimize skin contact.

- b. Wash filter screens thoroughly in solvent, per Federal Specification P-D-680, Type II. Allow filters to air dry.

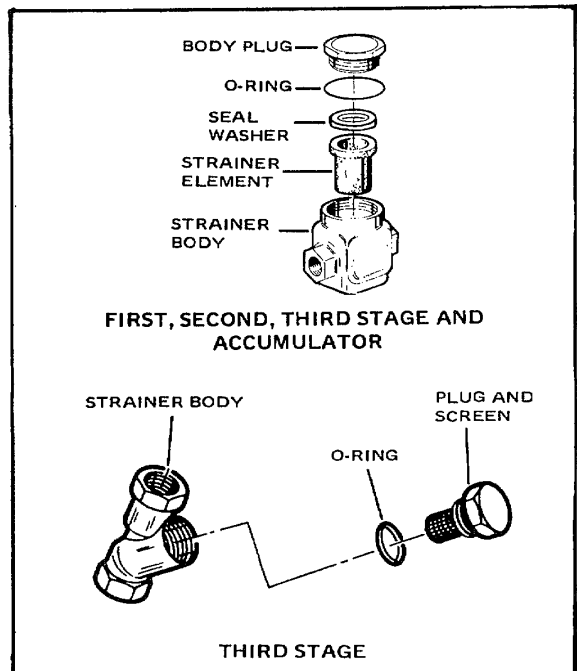

Figure 5-9. Line Strainers

- c. Wipe out cavity of trap and accumulator bodies with a lint free cloth dampened in solvent, per Federal Specification P-D-680, Type II. Allow bodies to air dry.



Take care not to damage the fine mesh filter screen.

- d. Check the filter screen for damage such as breaks and plugging due to corrosion; replace filter assembly, if damaged.
- e. Check o-ring for deterioration, cuts, or other damage. Replace as necessary.
- f. Install the o-ring and clean filter into top of trap body. Do not overtighten.

5-13. Line Strainers (Figure 5-9). Each time the trap filters are cleaned and inspected, refer to FIRST, SECOND, AND THIRD STAGE TRAPS (Section V). The line strainers shall be cleaned and inspected. To clean and inspect the line strainers, proceed as follows:

NOTE

For best results, use Ultrasonic Cleaner, NSN 4940-00-164-8977, (Table 2-1), to clean strainers and filters.

- a. From first and second stage line strainers, unscrew and remove the body plug, o-ring, washer, and filter element. From third stage, unscrew and remove the plug and screen assembly and o-ring.



Provide adequate ventilation when using dry cleaning solvent (Federal Specification P-D- 680, Type II). Avoid prolonged breathing of vapors and minimize skin contact.

- b. Wash line strainer filter elements and screen filter in- solvent, per Federal Specification P-D- 680, Type II. Allow filter element to air dry.
- c. Inspect elements and filter for any damage. Replace as necessary.
- d. Check all o-rings and seal washers for any damage; replace as necessary.

- e. Install o-ring and clean plug and screen assembly in third stage line strainer. Install element, seal washer, and body plug in first and second stage line filters.
- f. After compressor is started, check for leakage around plugs with a soapy water solution applied with a brush. Plug is leaking of solution bubbles.

5-14. Clutch Adjusting Yoke Adjustment (Figure 5-10). When clutch adjustment is necessary, disengage clutch by pulling the CLUTCH operating rod on the control panel, away from control panel and proceed as follows:

- a. Remove the four screws and lockwashers attaching the handhold cover to clutch housing assembly. Remove cover.
- b. Using START switch, rotate the engine crankshaft until the adjusting lock pin is accessible. Place a 1/16 inch thick washer of sufficient diameter over the lock pin.
- c. Using clutch adjustment tool (Table 2-1) disengage the lock pin from the floating plate. Insert cotter pin. Or equivalent, in the cross-drilled hole in the lock pin. Allow the cotter pin in the lock pin to come to rest on the washer; the lock pin is now locked in the out position.
- d. Using the clutch adjustment tool, turn the adjusting yoke in a clockwise direction until the lock pin in the adjusting yoke has passed one or two adjusting holes in the floating plate.
- e. Remove the cotter pin and washer from lock pin and allow lock pin to seat in adjusting hole in floating plate.
- f. Engage clutch. A distinct pressure should be felt when clutch is engaged. If not, repeat steps a through e until pressure is felt.
- g. Replace clutch housing cover and install washers and screws removed in step a.

5-15. Clutch Operating Rod Adjustment (Figure 5-11). Each time the clutch adjusting yoke is adjusted, refer to CLUTCH ADJUSTING YOKE ADJUSTMENT (Section V), the clutch operating rod shall be adjusted. To adjust the clutch operating rod, proceed as follows:

- a. Remove cotter pin and clevis pin.
- b. Loosen jam nut on clutch operating rod, turn rod yoke farther on to clutch operating rod or off on rod to shorten or lengthen effective stroke of clutch operating rod.

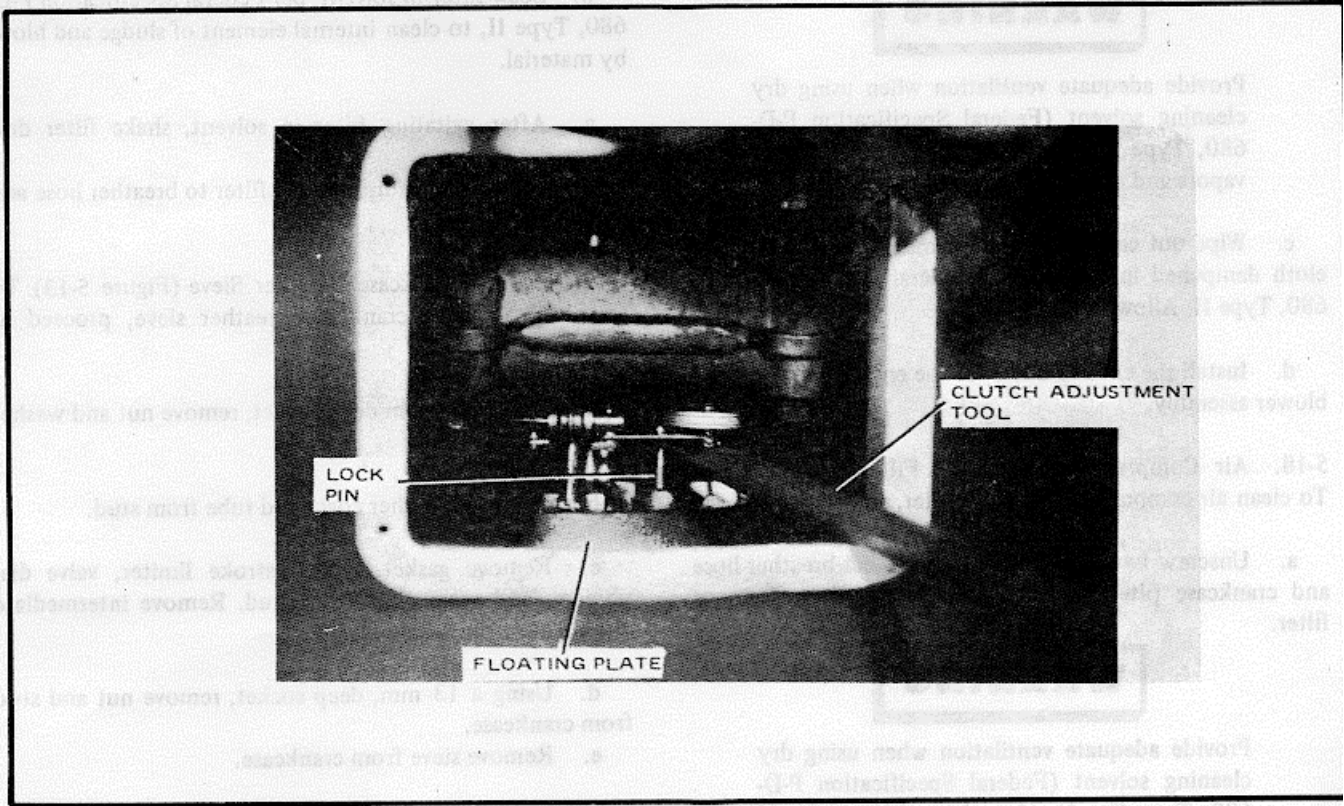

Figure 5-10. Clutch Adjusting Yoke Adjustment

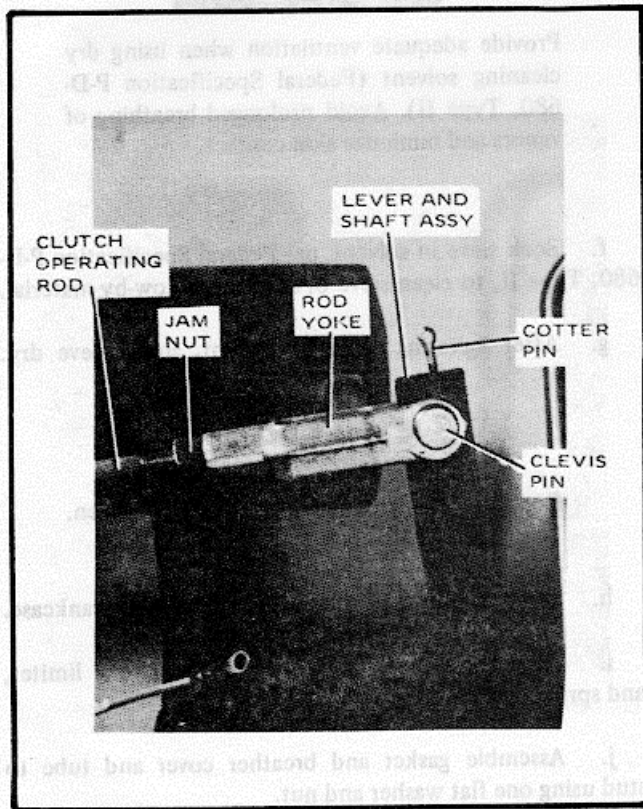

Figure 5-11. Clutch Operating Rod Adjustment

- c. Align rod yoke with hole in clutch and lever shaft, tighten jam nut on clutch operating rod, insert clevis pin through rod yoke and clutch and lever shaft; insert cotter pin in clevis pin.

5-16. Air Cooler Subassembly (Figure 1-1). To clean the outside surface of air cooler, proceed as follows:

WARNING

Air pressure used for drying or cleaning shall not exceed 30 psi (206.9 kPa).

- a. Clean outside surface of the air cooler with compressed air, pressurized hot water and detergent, or steam.

5-17. Engine Cooling Ducts and Blower Subassembly (25, Figure 8-30). To clean the engine's cooling ribs and blower, proceed as follows:

- a. Remove air cooling duct from blower assembly and engine cylinders.
- b. Using low pressure air, blow dust and residue from cooling ribs and blower fan.

WARNING

Provide adequate ventilation when using dry cleaning solvent (Federal Specification P-D- 680, Type 11). Avoid prolonged breathing of vapors and minimize skin contact.

- c. Wipe out cavity of cooling passages with a lint free cloth dampened in solvent, per Federal Specification P-D- 680, Type II. Allow to air dry.
- d. Install the cooling ducts for the engine cylinders and blower assembly.

5-18. Air Compressor Crankcase Filter (Figure 5-12). To clean air compressor crankcase filter, proceed as follows:

- a. Unscrew two hose clamps. Disconnect breather hose and crankcase filter hose from crankcase filter. Remove filter.

WARNING

Provide adequate ventilation when using dry cleaning solvent (Federal Specification P-D- 680, Type II). Avoid prolonged breathing of vapors' and minimize skin contact.

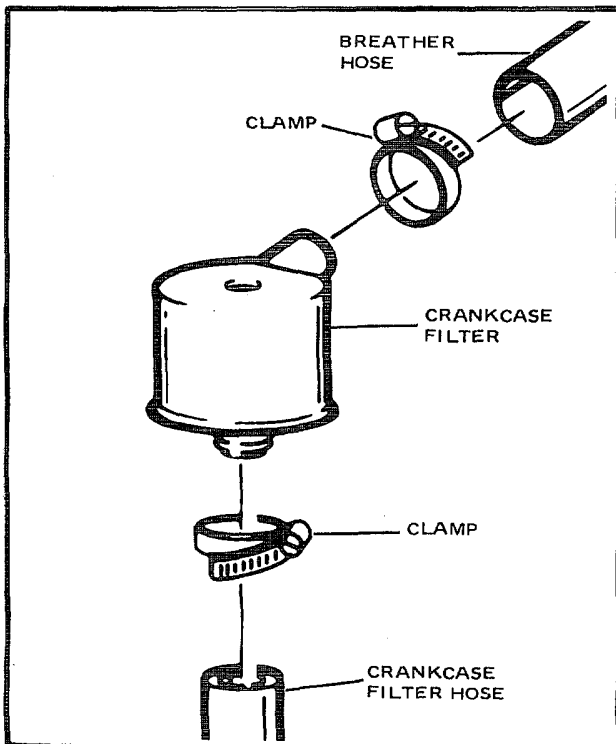

Figure 5-12. Air Compressor Crankcase Filter

- b. Soak filter in solvent, per Federal Specification P-D- 680, Type II, to clean internal element of sludge and blow-by material.
- c. After agitating filter in solvent, shake filter dry.
- d. Using hose clamps, attach filter to breather hose and crankcase filter hose.

5-19. Engine Crankcase Breather Sieve (Figure 5-13). To clean the engine's crankcase breather sieve, proceed as follows:

- a. Using a 13 mm deep socket, remove nut and washer from stud.
- b. Remove breather cover and tube from stud.
- c. Remove gasket, spring, stroke limiter, valve diaphragm, and valve plate from stud. Remove intermediate ring gasket from crankcase.
- d. Using a 13 mm, deep socket, remove nut and stud from crankcase.
- e. Remove sieve from crankcase.

WARNING

Provide adequate ventilation when using dry cleaning solvent (Federal Specification P-D- 680, Type II). Avoid prolonged breathing of vapors and minimize skin contact.

- f. Soak sieve in solvent, per Federal Specification P-D-680, Type II, to clean sieve of sludge and blow-by material.
- g. After agitating sieve in solvent, shake sieve dry.

CAUTION

Do not over tighten nut against sieve screen.

- h. Using one nut and stud, assemble sieve to crankcase.
- i. Place valve plate, valve diaphragm, stroke limiter, and spring over stud.
- j. Assemble gasket and breather cover and tube to stud using one flat washer and nut.

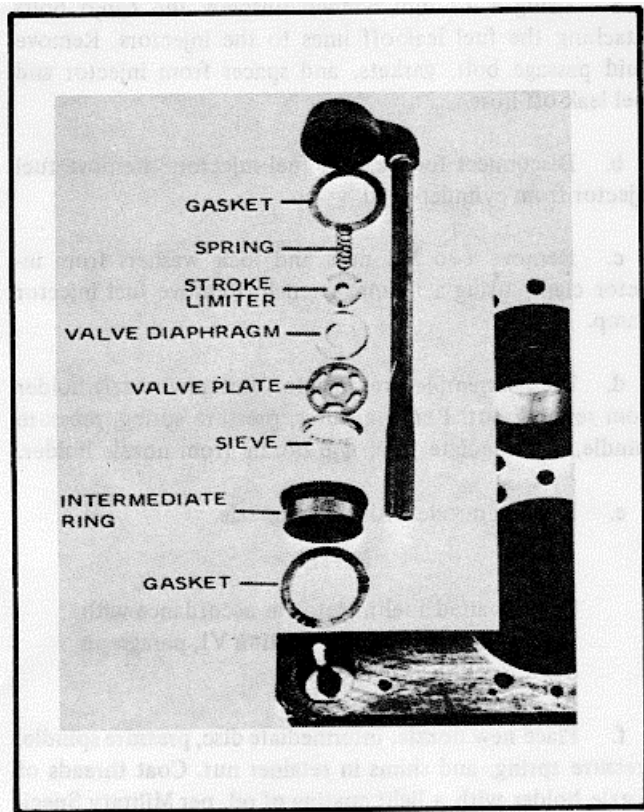

Figure 5-13. Engine Crankcase Breather Sieve

5-20. Engine Tappet Clearance Adjustment (Figure 5-14). To check tappet and adjust tappet clearance, proceed as follows:

NOTE

Tappet clearance check and adjustment shall be performed for both valves on each cylinder when the engine is cold.

- a. Unscrew and remove glow plug from cylinder head cover. Using a six mm allen wrench,
 - unscrew six 8 x 60 mm screws attaching cylinder head cover to cylinder heads. Remove cover.
- b. Using START switch turn engine until both valves of cylinder one are closed.
- c. Disconnect negative battery cable.
- d. Using a feeler gauge, check for 0.004 inch (0.10 mm) clearance between both valve stems and rocker arms.
- e. If gap clearance is incorrect, loosen jam nut and adjust adjusting screw until feeler gauge can be pulled between valve stem and rocker arm with just noticeable resistance. Tighten nut.

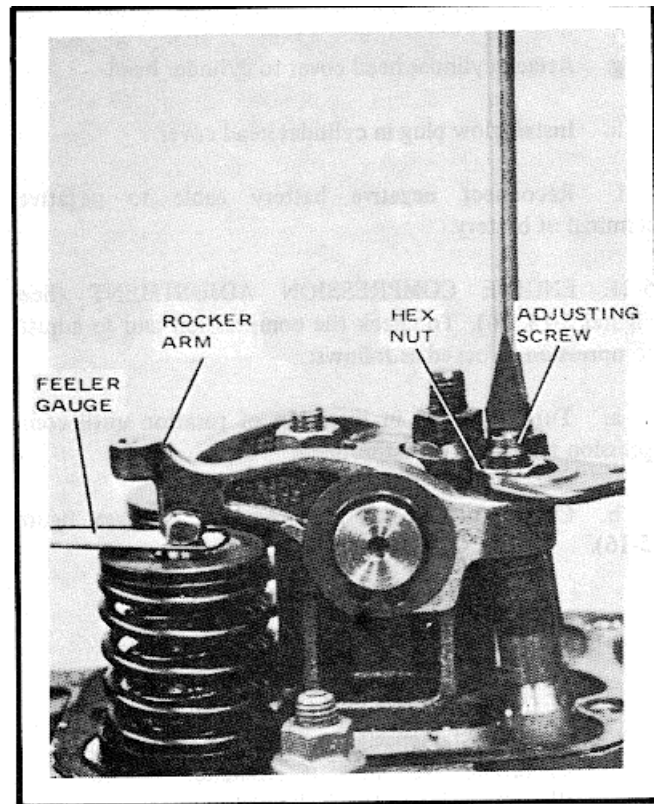

Figure 5-14. Engine Tappet Adjustment

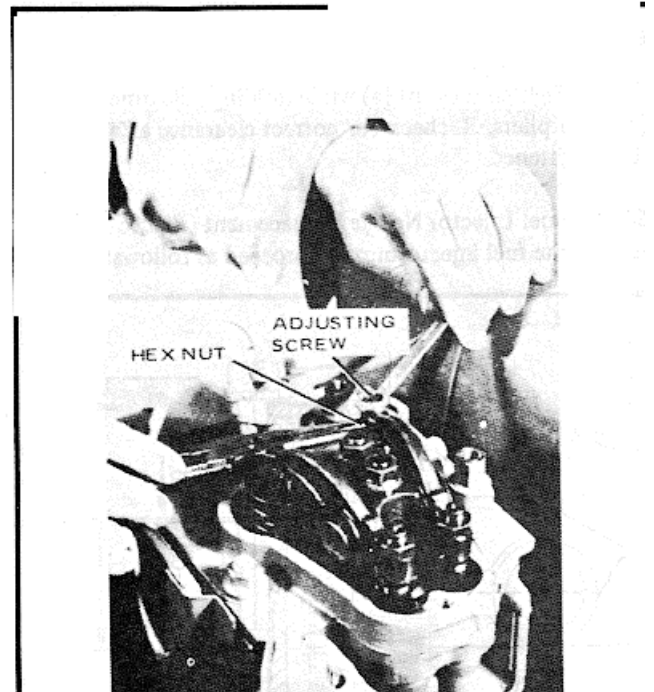

Figure 5-15. Engine Compression Adjustment

- f. Repeat steps b through e for cylinder number two.
- g. Attach cylinder head cover to cylinder head.
- h. Install glow plug in cylinder head cover.
- i. Reconnect negative battery cable to negative terminal of battery.

5-21. ENGINE COMPRESSION ADJUSTMENT (See Figures 5-15, 16). To check the compression and to adjust compression, proceed as follows:

- a. Turn flywheel in direction of rotation until compression resistance is first noticed.
- b. Check and record measurement "A" (see figure 5-16).



In the decompressed position, the valve must open just far enough so that the engine can be turned over without resistance. Do not allow the valve to touch the piston.

- c. Loosen lock nut (a) and adjustment screw (6) using a feeler gauge set at 0.012 inch (0.3 mm). Using a pair of pliers, adjust screw.
- d. Tighten lock nut (a) while holding adjustment screws (b) with pliers. Recheck for correct clearance after lock nut (a) is tightened.

5-22. Fuel Injector Nozzle Replacement (Figure 5-17). To replace the fuel injector nozzle, proceed as follows:

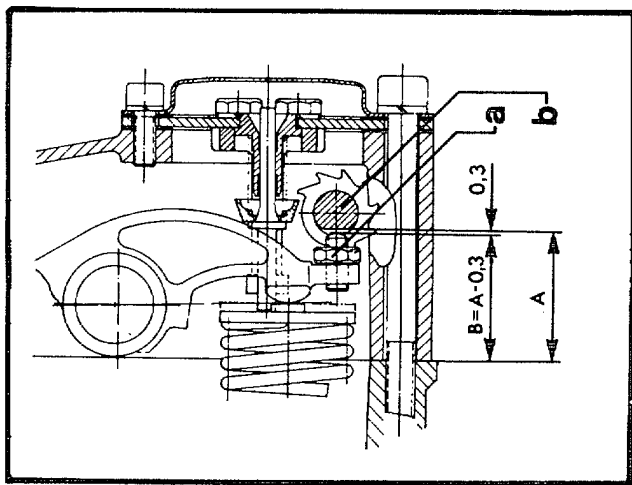

Figure 5-16. Engine Compression Adjustment Tolerances

- a. Using a 12 mm wrench unscrew the banjo bolts attaching the fuel leak-off lines to the injectors. Remove fluid passage bolt, gaskets, and spacer from injector and fuel leak-off hose.
- b. Disconnect fuel lines at fuel injectors. Remove fuel injector from cylinder head.
- c. Remove two M8 nuts and lock washers from injector clamp using a 13 mm wrench. Remove fuel injector clamp.
- d. To disassemble fuel injector, unscrew nozzle holder from retainer nut. Remove shims, pressure spring, pressure spindle, intermediate disc, and nozzle from nozzle holder.
- e. Replace nozzle with a new nozzle.

NOTE

Test repaired fuel injector in accordance with instructions set forth in Section VI, paragraph 6-39, Fuel Injector Assembly.

- f. Place new nozzle, intermediate disc, pressure spindle, pressure spring, and shims in retainer nut. Coat threads of nozzle holder with a light coating of oil, per Military Specification MILL-2104 or equivalent. Screw nozzle holder into retainer nut. Tighten holder to 63 pounds-foot (85Nm) torque.



Make certain washer is properly positioned in cavity of cylinder head.

- g. Place assembled fuel injector in cavity of cylinder head.
- h. Place clamp over injector.
- i. Attach clamp to cylinder head using two washers and nuts.
- j. Connect fuel pressure lines to injector.
- k. Connect fuel leak-off hose to injector using spacer, washers, and a fluid passage bolt.
- l. Repeat steps a through k for fuel injector number two.

5-24. LUBRICATION INSTRUCTIONS. Points of lubrication, type of lubricant, application, and time interval are listed in Table 5-3. Detailed instructions are as follows:

NOTE

So oil will flow more freely, drain oil from the engine crankcase while the engine is hot.

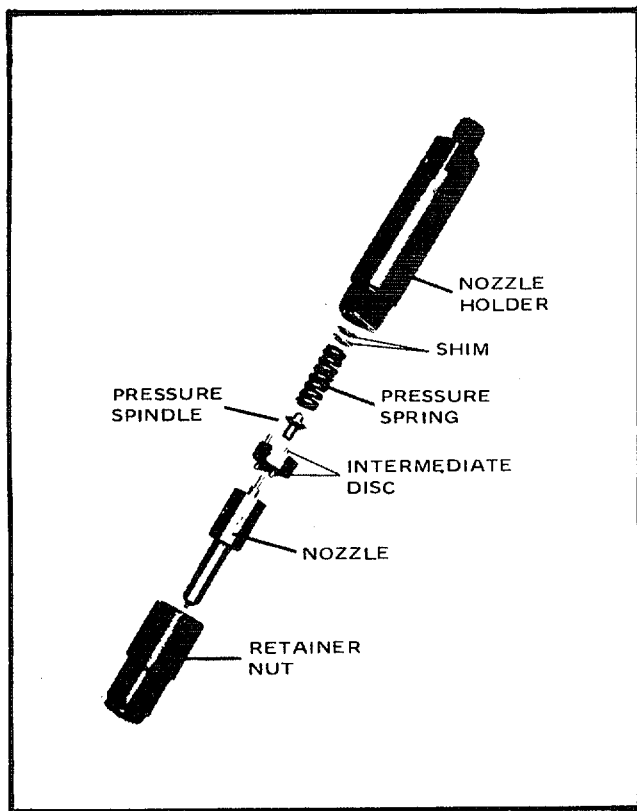

Figure 5-17. Fuel Injector Nozzle

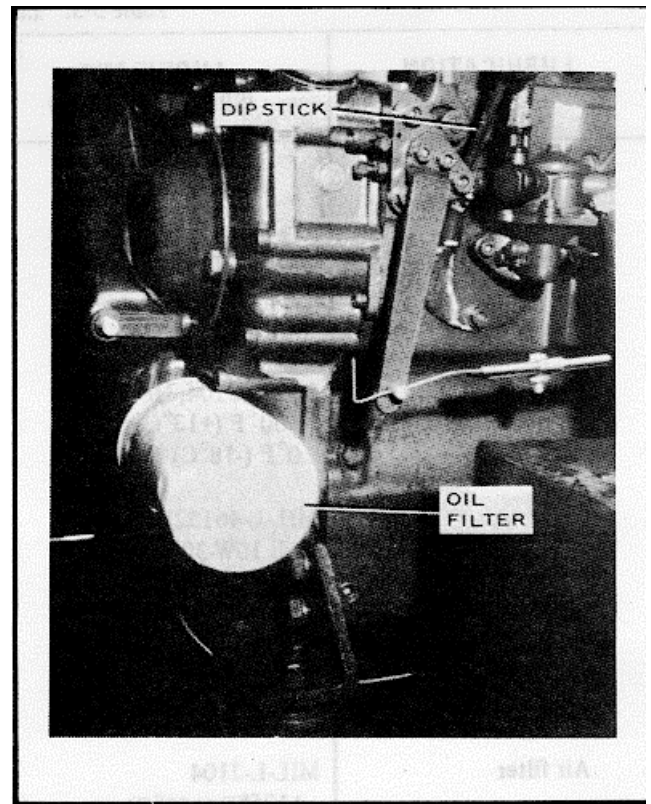

Figure 5-18. Engine Oil Filter

5-25. Engine Lubricating Oil. Change the engine oil as follows.

- a. Place a container under engine oil drain. Open oil drain valve and allow all oil to drain from engine.
- b. When oil flow stops, close drain valve.
- c. Remove oil filler cap from engine crankcase and fill crankcase with five quarts of clean lubricating oil (refer to Table 5-3). When engine oil filter is changed, fill crankcase with six quarts of oil. Install filler cap.
- d. Remove container from beneath engine drain and discard old oil.
- e. After engine has been started and operated for approximately ten minutes, stop engine, remove oil level dipstick and check oil level. If not to the full mark, add enough oil to bring to full mark.

5-26. Engine Oil Filter (Figure 5-18). To change the engine's oil filter, proceed as follows:

- a. Remove filter by turning counterclockwise using a screw driver, or strap wrench.

- b. Wipe the contact surface of the new filter clean of all dirt and coat rubber gasket with clean engine oil.

NOTE

Do not use screwdriver or strap wrench to install filter.

- c. Clean the mating surface of the oil filter adapter on the engine. To install oil filter, place a light film of clean oil on filter gasket, mount and hand turn the new filter clockwise until the gasket makes contact with the mounting flange.
- d. Hand turn the filter an additional half turn clockwise.

5-27. Compressor Lubricating Oil. Change compressor lubricating oil as follows.

NOTE

So oil will flow more freely, drain oil from the compressor sump while compressor is hot.

- a. Place a container under the compressor oil drain. Remove the drain plug and allow all oil to drain from the compressor.

Table 5-3. Lubrication Instructions

LUBRICATION POINT	LUBRICATION (SPECIFICATION)	APPLICATION (OR ACTION)	INTERVAL (SERVICE HOURS)
<p>ENGINE Crankcase</p> <p>Oil filter</p> <p>Air filter +1250F (+520C) to</p> <p>COMPRESSOR Sump Oil filter</p> <p>CLUTCH Lubrication fitting</p>	<p>MIL-L-2104, HDO-30 +125°F (+520C) to +60°F (+130C) MIL-L-2104, HDO-10 +600F (+130C) to 0°F (-18°C) MIL-L-46152B SAE O1W-30 +50°F (+10°C) to +86°F (+30°C) 820 42 150 hours or 6 months MIL-L-2104 HDO-30 +60°F (+13°C) +60°F (13°C) to 0°F (-18°C)</p> <p>MIL-L-17331 PER- I</p> <p>GAA-Grease MIL-G-10924</p>	<p>Drain and refill.</p> <p>Change element</p> <p>Drain and refill.</p> <p>HDO-30</p> <p>Drain and refill. Change element.</p> <p>Grease gun.</p>	<p>First change (new engine) 25 hours</p> <p>150 hours or 6 months</p> <p>At 1st change, then at 150 hours or 6 months</p> <p>150 hours or 6 months. 150 hours or 6 months.</p> <p>150 hours or 6 months.</p>

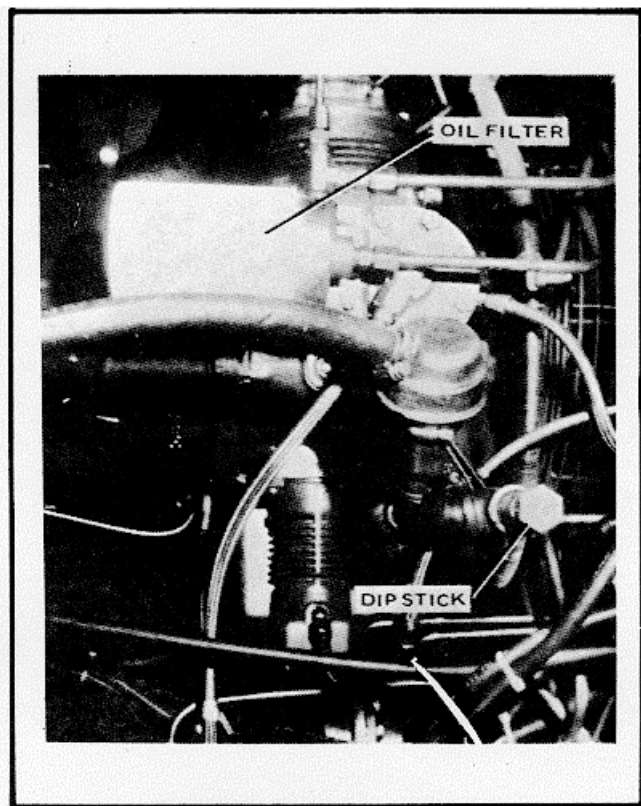

Figure 5-19. Compressor Oil Filter

- b. When oil flow stops, install drain plug. Service compressor oil filter, refer to COMPRESSOR OIL FILTER (Section V), at proper interval. Service compressor air filter, refer to COMPRESSOR AIR FILTER (Section V), at proper interval.
- c. Remove compressor oil level dipstick from filler pipe. Fill compressor oil sump with four quarts of clean lubricating oil (refer to Table 5-3). When compressor oil filter is changed, fill sump with five quarts of oil. Install dipstick.
- d. Remove container from beneath compressor drain and discard old oil.

5-28. Compressor Oil Filter (Figure 5-19). To change the compressor's oil filter, proceed as follows:

- a. Turn filter counterclockwise using a strap wrench.
- b. Wipe the contact surface of the new filter clean of all dirt and coat the rubber gasket with clean oil.
- c. Clean the mating surface of the adapter on the compressor. To install filter, hand turn the new filter clockwise until the gasket just contacts the mounting bracket. Do not use a strap wrench to install filter.

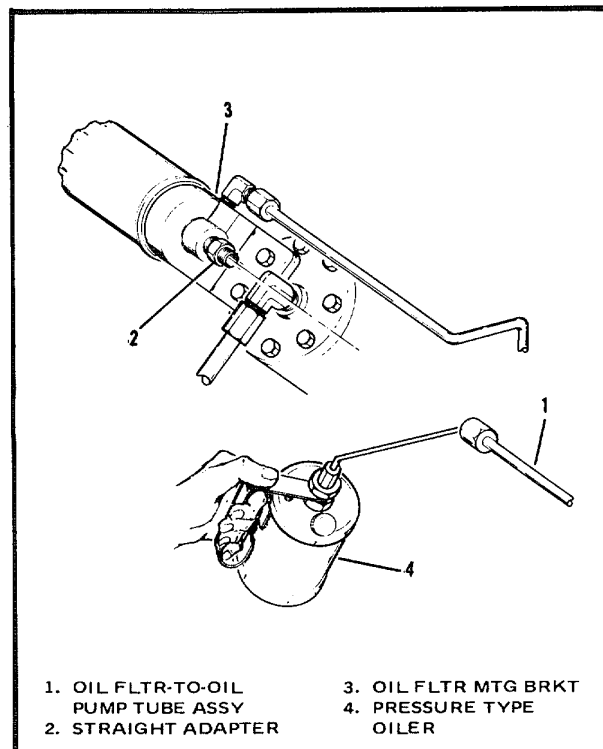

Figure 5-20. Priming Air Compressor Assembly Oil Pump

- d. Hand turn the filter an additional half turn clockwise.
- 5-29. Priming Air Compressor Assembly Oil Pump. (Figure 5-20). To prime the air compressor assembly oil pump, proceed as follows:

NOTE

After changing the oil filter or putting an air compressor unit into service, which has been idle or in storage for a considerable length of time, it may be necessary to prime the compressor pump to obtain a correct air compressor oil pressure indication.

- a. Disconnect oil filter-to-oil pump tube assembly (1) at adapter (2) on oil filter mounting bracket (3).
- b. Raise oil filter-to-oil pump tube (1) slightly above adapter (2).
- c. Using a pressure type oiler (4), containing compressor lubricating oil as specified in Table 5-3, fill oil filter-to oil pump tube (1) until oil flows from tube.
- d. Connect oil filter-to-oil pump tube (1) to adapter (2).

5-30. (Clutch Lubrication. Lubricate the clutch lubrication fitting located inside access hole recessed in the left-hand side of the clutch housing. Opposite side of clutch housing from the clutch lever.) Use a grease gun and lubricant specified in Table 5-3.

5-31. TROUBLESHOOTING. A tabulation of troubleshooting is contained in Table 54. This table will aid and guide the maintenance personnel by indicating the possible malfunctions that may occur during operation of the air compressor unit. The table lists probable causes of and possible remedies for correcting the malfunctions. The malfunctions and possible causes are listed in the order in which they are most apt to occur. The remedies for corrective action include servicing, adjusting, or replacing the component causing the trouble. The remedy may reference other detailed paragraphs of this manual. Once the malfunction has been isolated and corrected, perform OPERATIONAL CHECKOUT (Section V) to ensure proper operation of the air compressor unit.

Table 5-4. Troubleshooting

TROUBLE	PROBABLE CAUSE	REMEDY
1. Engine fails to start, or starts then stops.	1. Insufficient fuel supply	1. Refer to Table 6-1 and fill tank with appropriate fuel. If fuel tank has sufficient fuel supply check for kinked hoses/lines, proceed to probable cause 2.
	2. Fuel filter clogged	2. Refer to FUEL FILTER (Section V) clean and change fuel filter. If fuel filter is not clogged, proceed to probable cause 3.
	3. Wire lead from 15 (Figure 7-2) disconnected from fuel solenoid valve	3. Connect wire lead to solenoid If lead is connected to solenoid, proceed to probable cause 4. Check to see if wire has current.
	4. Throttle control cable retainer screw loose at speed control lever cable is stop	4. Tighten screw in cable stop. If screw tight, refer to probable cause 5.
	5. Fuel transfer pump malfunctioning	5. Refer to INSPECTION (Section V) and perform fuel transfer pump tests. If pump is operating properly proceed to probable cause 6.
	6. Fuel injection pump malfunctioning	6. Refer to REPAIR (Section V) and perform fuel injection pump tests. If pump is operating properly, proceed to probable cause 7.
	7. Fuel injector is malfunctioning.	7. Refer to REPAIR (Section V) and perform fuel injector test. If injector/s are operating properly, proceed to probable cause 8.
	8. Engine out of time	8. Refer to REPAIR (Section V) and time engine. Timing will not change unless shim pack under pump is disturbed.
	9. Air in fuel system	9. Check for loose lines and damaged sealing washers.
2. Engine is hard to turn	1. Wrong grade lubricating oil	1. Refer to Table 5-3 and fill within correct oil. If engine is still hard to turn, refer to probable cause 2.
	2. Tappet clearance incorrect	2. Refer to INSPECTION AND PREVENTIVE MAINTENANCE (Section V), check and adjust tappet clearance. If tappet clearance is correct, refer to probable cause 3.

Table 5-4. Troubleshooting - Continued

TROUBLE	PROBABLE CAUSE	REMEDY
2. Engine is hard to turn (Continued)	3. Engine exhaust restricted	3. Inspect engine exhaust system. If exhaust system is not restricted, proceed to probable cause 4.
	4. Poor electrical connections or bad starter	4. Clean connections and tighten as necessary.
	5. Engine exhaust valve/s stuck closed	5. Examine valve/s and valve seat/s. If valves are not sticking, proceed to probable cause 6.
	6. Injector/s leaking into cylinder/s causing hydraulic lockup.	6. Refer to REPAIR (Section V) and perform fuel injector leak test. If injector/s is/are not leaking, proceed to probable cause 7.
	7. Piston/s seizing on cylinder wall/s.	7. Refer to REPAIR (Section V) and examine pistons and cylinders for evidence of seizing. Replace all defective parts.
3. Black smoke coming from exhaust	1. Air filter clogged	1. Refer to INSPECTION AND PREVENTIVE MAINTENANCE (Section V) and service filter. If air filter is not clogged, refer to probable cause 2.
	2. Clogged engine fuel injector nozzle	2. Refer to INSPECTION AND PREVENTIVE MAINTENANCE (Section V) and replace fuel injector nozzle/s. If nozzle/s is/are clogged, refer to probable cause 3.
	3. Tappet clearance incorrect	3. Refer to INSPECTION AND PREVENTIVE MAINTENANCE (Section V), check and adjust tappet clearance. If tappet clearance is correct, refer to probable cause 4.
	4. Injector/s not tightened to proper torque value.	4. Refer to Table 5-6 and check injector retaining nuts torque value. If torque value is correct, proceed to probable cause 5.
	5. Dirty injector/s	5. Refer to REPAIR (Section V) and clean injector/s. If injector/s are clean, proceed to probable cause 6.
	6. Worn engine intake and/or exhaust	6. Examine valves and valve seat/s for evidence of wear. Replace all defective parts.
	7. Collapse or kinked air intake hose	7. Replace hose.

Table 5-4. Troubleshooting - Continued

TROUBLE	PROBABLE CAUSE	REMEDY
4. Engine overheats	1. Lack of cooling air	1. Clean cooling air inlet. If cooling air inlet is clean, refer to probable cause 2.
	2. Excessive oil in crankcase	2. Refer to Table 5-3, drain oil to normal level. If oil level is correct, refer to probable cause 3.
	3. Improper injector nozzle/s spray	3. Refer to INSPECTION AND PREVENTIVE MAINTENANCE (Section V) and replace injector nozzle/s. If nozzle/s is/are not at fault, refer to probable cause 4.
	4. Timing of fuel injection pump incorrect.	4. Refer to REPAIR (Section V). Check and reset pump timing if necessary. If pump timing is correct, proceed to probable cause 5.
	5. Loose, worm, or damaged engine components causing excessive friction	5. Refer to REPAIR (Section V), disassemble engine assembly. Replace parts which are worn.
5. Engine loses power. (Engine rpm [r/min] drops under load)	1. Lack of combustion air	1. Refer to trouble number 3, probable causes and remedies 1 and 2. If lack of combustion air is not at fault, proceed to probable cause 2.
	2. Tappet clearance incorrect cause and remedy 3	2. Refer to trouble number 3, probable cause 3. If tappet clearance is correct, refer to probable cause 3.
	3. Cylinder head attaching nuts not tightened to correct torque value.	3. Check and tighten nuts to correct torque value if necessary. If nuts are correctly tightened, refer to probable cause 4.
	4. Defective cylinder head gasket	4. Remove and inspect cylinder head gasket. Replace a defective gasket. If gasket is not defective, refer to probable cause 5.
	5. Valves sticking or not seating correctly or piston rings worn (compression not up to specifications.)	5. Disassemble cylinder head. Check cylinder head parts and replace or repair parts that show damage or excessive wear. Reassemble cylinder head.
	6. Air in fuel system	6. Check and tighten any loose fuel line hardware, and replace damaged sealing washers.

Table 5-4. Troubleshooting - Continued

TROUBLE	PROBABLE CAUSE	REMEDY
6. Engine stops suddenly.	1. Air filter clogged	1. Refer to INSPECTION AND PREVENTIVE MAINTENANCE (Section V) and service filter. If air filter is not clogged, refer to probable cause 2.
	2. Fuel tank empty	2. Refer to Table 5-3 and fill with appropriate fuel. If fuel tank is not empty, refer to probable cause 3.
	3. Incorrect fuel supply	3. Drain fuel tank, refer to Table 5-3 and fill tank with appropriate fuel. If fuel supply is correct, refer to probable cause 4.
	4. Fuel system clogged or leaking	4. Refer to trouble 3, probable causes and remedies.
	5. Throttle cable slipping	5. Tighten cable.
7. Engine becomes overloaded when compressor is driven through clutch	1. Compressor cylinders scored; defective compressor bearing	1. Disassemble, clean, inspect and repair compressor as necessary. Refer to REPAIR (Section VI). If parts are not defective, refer to probable cause 2.
	2. Compressor valves broken, stuck, or carbonized.	2. Remove the compressor valves, clean, inspect and replace as necessary Refer to REPAIR (Section V). If parts are not defective, refer to probable cause 3.
	3. Engine malfunctioning	3. Refer to all above engine troubles, probable causes, and remedies.
8. Compressor does not operate at proper speed when clutch is engaged	1. Clutch slipping	1. Adjustment clutch Refer to INSPECTION AND PREVENTIVE MAINTENANCE (Section V) and adjust clutch. If clutch is adjusted properly, refer to probable cause 2.
	2. Engine malfunctioning	2. Refer to all preceding engine troubles, probable causes, and remedies If engine is operating properly, refer to probable cause 3.
	3. Air compressor assembly malfunctioning	3. Refer to REPAIR (Section VI), disassemble air compressor. Check compressor parts against limits specified in Table 5-5. Replace parts which are worn beyond permissible limits.

Table 5-4. Troubleshooting - Continued

TROUBLE	PROBABLE CAUSE	REMEDY
9. COMPRESSOR OIL PRESSURE gauge indication too low	1. Compressor oil level in crankcase too low	1. Add oil to compressor oil sump to full mark on dipstick. If dipstick indicates correct oil level, proceed to probable cause 2.
	2. Prime oil line for compressor	2. Prime air compressor oil pump Refer INSPECTION AND PREVENTIVE MAINTENANCE (Section V) and prime air compressor assembly oil pump. If oil pump is primed, refer to probable cause 3.
	3. Viscosity of oil too low for operating ambient temperature.	3. Change oil in compressor crankcase. Refer to LUBRICATION INSTRUCTIONS (Section V) and Table 5-3 for ambient temperature. If oil is of correct viscosity, refer to probable cause 4.
	4. Compressor oil pump defective preventing proper circulation	4. Remove oil pump, disassemble, clean inspect, and repair as necessary If pump is not defective, refer to probable cause 5.
	5. Crankshaft oil seals worn causing - leak age resulting in probable cause 1.	5. Replace worn oil seals Refer to REPAIR(Section VI).If oil seals are not defective, refer to probable cause 6.
	6. Defective COMPRESSOR OIL PRESSURE gauge.	6. Replace a defective gauge Refer to REPAIR (Section VI), If gauge is not defective, refer to probable cause 7.
	7. Oil pressure relief spring broken	7. Replace broken oil pressure relief spring. Refer to REPAIR (Section VI).
10. COMPRESSOR OIL PRESSURE gauge indicating too pressure	1. Defective COMPRESSOR OIL PRESSURE gauge.	1. Replace a defective gauge. Refer to REPAIR (Section VI). If gauge is not defective, refer to probable cause 2.
	2. Compressor oil pressure relief ball stuck.	2. Remove and thoroughly clean oil pressure relief ball, spring, and oil passage. Replace any damaged parts. Refer to REPAIR (Section VI). If ball is not stuck, refer to probable cause 3.
	3. Oil pressure relief spring too long or too stiff.	3. Replace oil pressure relief spring with correct replacement spring. Refer to REPAIR (Section VI).

Table 5-4. Troubleshooting - Continued

TROUBLE	PROBABLE CAUSE	REMEDY
11. Compressor Output Pressure gauge indication higher than 3200 psi (22,048 kPa) while compressor is in load mode	1. Unload control pressure switch out of adjustment or faulty	1. Adjust the unload control pressure switch or replace if faulty. Refer to Operational Checkout, Section V.
	2. Accumulated condensate not being disposed of fast enough or often enough.	2. Place compressor unloader switch to unload position. Unloading should occur at least once every 90 minutes. If not, refer to probable cause No. 3.
	3. Clogged orifice of continuous bleed valve.	3. Clean orifices of bleed valves, and screws in the strainers.
	4. Obstruction in air cooler tubing	4. Remove the tubing and clean thoroughly to remove obstruction.
	5. Compressor output pressure gauge indicating improperly.	5. Replace faulty gauge.
12. Compressor Output Pressure gauge indication is less than 3200 psi (22,048 kPa) when compressor is loaded, or compressor does not deliver enough air	1. Leaking compressor lines	1. Tighten connections as necessary. Replace any tube or hose line leaking, or any fitting not seating properly.
	2. Safety valves on air cooler not working properly.	2. Replace a leaking safety valve.
	3. Valve in air compressor cylinder head leaking or not working properly.	3. Replace defective valve assembly.
	4. Automatic drain valve leaking	4. Remove and clean drain tubing, replace if necessary. If the tubing is satisfactory check the adjustment on the pressure switch.
	5. Air leaking from mechanical filter	5. Tighten the filter head assembly.
	6. Air leaking from dehydrators Cyl's 1 and 2, (19, 22, Figure 8-2)	6. Tighten the dehydrator cap assemblies.
	7. Air leaking from air purification cylinders (3, 4, 5, 23, 24, 25, Figure 8-2)	7. Tighten the air purifier cap assemblies.
	8. Air leaking from ten-micron air filter.	8. Tighten filter bowl.
	9. Air leaking past a compressor cylinder head gasket.	9. Replace the cylinder head gasket. Tighten cylinder head cap screws to correct torque value (Table 5-6).
	10. Piston rings worn	10. Replace defective piston rings.
13. Air Compressor	For Troubleshooting procedures, probable cause and remedies on Davey Compressor high pressure air ends, refer to Table 2-1, Test Stand, High Pressure Air End.	

SECTION VI.

REPAIR SECTION

6-1. REPAIR. The following paragraphs contain maintenance instructions for the air compressor unit. These instructions will enable maintenance personnel to repair or replace defective parts, allowing the air compressor unit to meet new equipment standards of operation. Instructions are included for the disassembly, cleaning, inspection, repair or replacement, assembly of detailed parts into subassemblies, subassemblies into assemblies, and final assembly of assemblies to form a complete air compressor unit.

NOTE

After performing any repair upon the air compressor unit, refer to TEST (Section VI) and test air compressor unit to ensure proper operation.

6-2. Preliminary Procedures. In general it is not necessary to completely disassemble the air compressor unit as illustrated in Figure 1 (Section VIII). Operational checkout and troubleshooting will indicate the required degree of disassembly necessary and assemblies which require repair or replacement. Prior to complete disassembly of the air compressor unit, the following step-by-step procedures shall be completed as follows:

WARNING

Never attempt to disassemble any part of the air compressor unit without first having relieved all air pressure from the system.

a. On control panel, open the service valve, dehydrator bleed valve, mechanical filter drain valve and the service hose bleed valve.

b. Remove battery cables from battery (3, Figure 8-37).

c. Remove two wing nuts (1), J-bolts (5) and battery retainer (2) from frame. Remove battery (3) from compressor unit and store in a heated area. Replace J-bolts, battery retainer and wing nuts.

d. Place a container under engine oil drain, and drain lubricating oil from engine.

e. Place a container under compressor oil drain, remove oil drain plug and drain lubricating oil from compressor. Install drain plug.

f. Place compressor unit on suitable work stands, place a container under fuel tank drain, loosen filter filler cap (21, Figure 8-37). Remove drain plug (22) from fuel tank and drain fuel. After fuel has drained from tank, install drain plug.

g. Remove oil container from engine air filter (23, Figure 8-30) and drain oil from container. Replace container.

6-3. AIR COMPRESSOR UNIT. The following paragraphs contain disassembly, cleaning, inspection, repair or replacement, and assembly instructions for the air compressor unit. General shop practice standards for maintenance and overhaul shall be followed on all assemblies. General cleaning, inspection, and repair or replacement is as follows:

WARNING

Provide adequate ventilation when using cleaning solvent (Federal Specification P-D680, Type II). Avoid prolonged breathing of vapors and minimize skin contact.

CAUTION

Solvents conforming to Federal Specification P-D-680, Type II shall not be used to clean any parts of the trap mounting group other than those specified herein. These solvents may cause damage to paint coatings, plastics, and rubber. Disposal of solvents conforming to Federal Specification P-D-680, Type II shall be accomplished in accordance with local state water pollution control laws. Consult local bioenvironmental engineer for guidance. In no instance should these solvents be allowed to contaminate streams or lakes. They may be disposed of by evaporation or burning under supervision.

NOTE

Do not allow parts to remain in cleaning solvent for extended periods of time or rust spots may form. If parts are not to be inspected immediately after cleaning, dip them in engine oil per Military Specification MI.-I.2104C or equivalent. Do not immerse electrical parts in cleaning solvent.

a. Cleaning.

- (1) Clean all unpainted metal parts using cleaning solvent that is in accordance with Federal Specification P-D-680, Type II, or equivalent. Wipe nonmetallic parts with a clean, lint-free cloth moistened in detergent and water and air dry.
- (2) Clean all painted surfaces by spraying with hot water and detergent solution per Federal Specification P-D-220. Parts that will be repainted may be cleaned with steam. After cleaning, refinish affected painted areas where required.



Do not use steam or water to clean any electrical components or assemblies such as electrical gauges, switches and solenoids.

- (3) Clean electrical components with trichloroethane, per Federal Specification O-T-620 or equivalent.



Proper precautions must be exercised to protect personnel. Stand clear of all tubing openings. After cleaning, drain tubes, and dry with low pressure compressed air (30 psig maximum [206 KPa]).

- (4) Clean outside and inside surfaces of the steel tubing assemblies with compressed air, pressurized hot water and detergent or steam.

b. Inspection. In general, inspect as follows:

- (1) Inspect for visible wear, damage, distortion, cracks, breaks, and corrosion. Replace all o-rings, gaskets and seals.
- (2) Inspect threaded parts for stripped threads, cross-threading and for nicks and burrs.
- (3) Inspect hoses and tubing for evidence of leaks, cracks, pinching, chaffing conditions, damaged connecting nuts, and similar defects.
- (4) Examine all electrical wiring for broken insulation, evidence of burning (indicating a short), loose connections and damaged terminals.
- (5) Inspect painted surfaces for chipping, peeling or discolored paint.

c. Repair or Replacement. For the most part, repair of this equipment will be made by replacement of worn or damaged parts. Detailed repair and replacement procedures

for specific parts are found in the following subassembly paragraphs.

NOTE

Many repair parts for this equipment are provided in the form of kits. Refer to Section VIII, Illustrated Parts Breakdown for details. Activities shall replace all parts (regardless of condition) which are removed in the process of disassembly with all like parts furnished in kits. Therefore, instructions for cleaning, inspecting, and repair of used parts found in kits have been omitted from this manual. If any kit parts must be cleaned, inspected, or tested prior to installation, instructions for performing these requirements are included at the appropriate detailed instruction location. An installed part which is not defective need not be removed solely for the purpose of replacement by a corresponding kitted part. Residue from kits and removed parts in this category shall be administratively condemned.

- (1) Minor nicks, scoring or scratches on non-critical surfaces may be smoothed with crocus cloth per Federal Specification P-C458.
- (2) Repair or replace damaged or defective steel tubing. To repair or replace steel tube assemblies attachment fittings, proceed as follows:

NOTE

Before attempting to repair tube fittings, make certain stainless steel tubing is of sufficient length to fit after cutting off end containing damaged fittings. If not long enough, replace whole tube assembly.

- (a) Cut off tubing just beyond damaged fitting.
- (b) Slide tubing nut and then the sleeve onto the tubing, refer to Figure 6-1. Make certain end of tubing is free of any burrs and is reasonably square.
- (c) Insert the end of the tubing into mating fitting, see Figure 6-2. Make certain that tubing end is bottomed on fitting shoulder. Apply a good grade of lubricant on end of tubing.
- (d) Turn tubing nut slowly with wrench while turning tubing with other hand. When the sleeve grips the tubing, that is when tile tubing can no longer be turned by hand, stop turning nut and note position of wrench. This is termed the ring grip point.

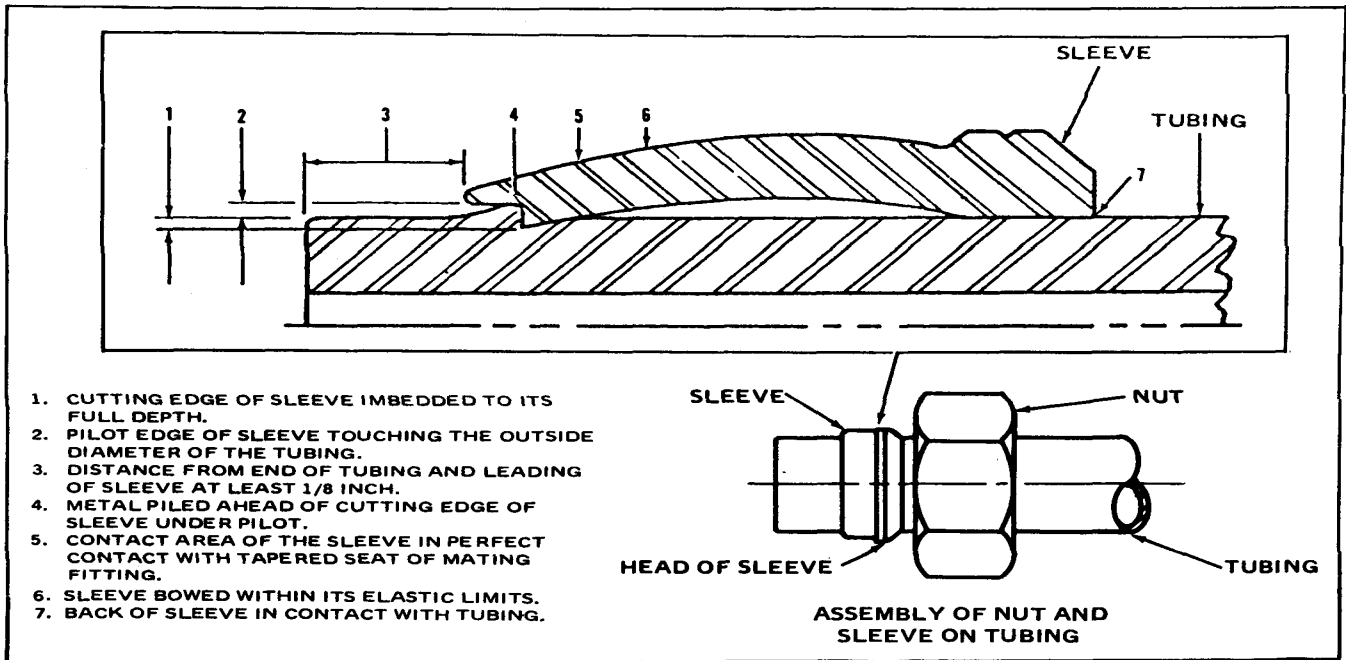

Figure 6-1. Steel Tubing and Fitting Assembly

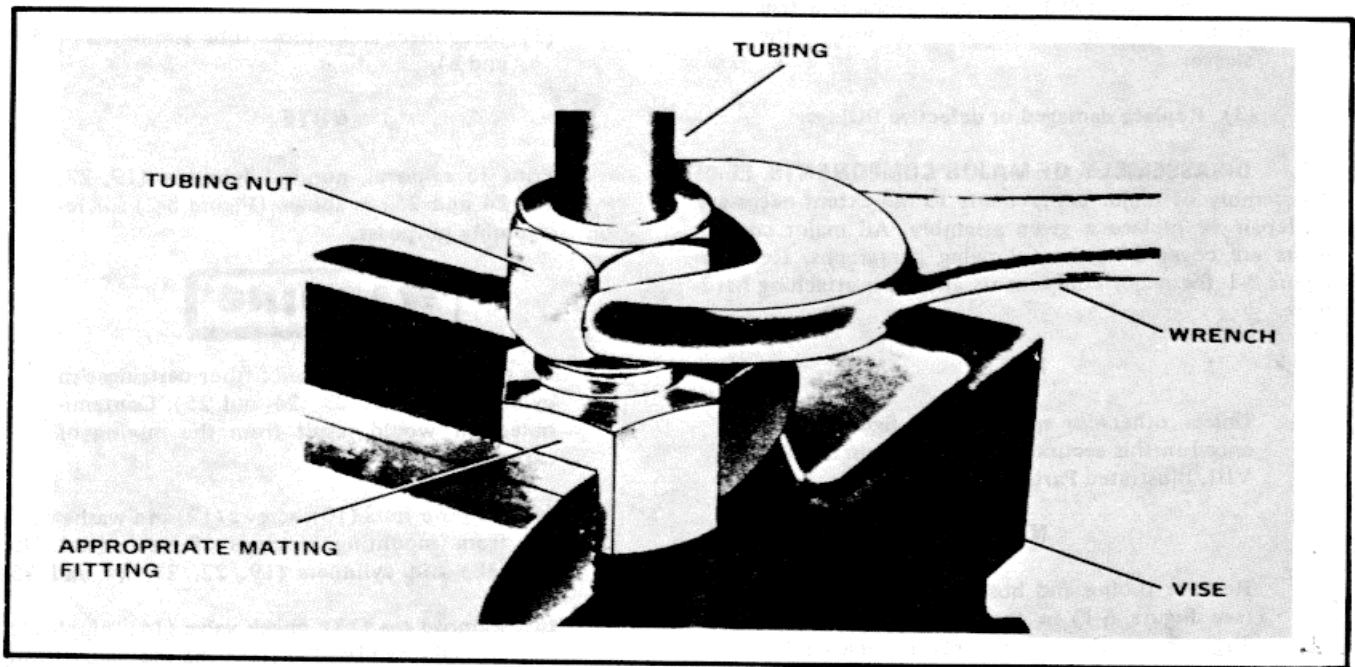

Figure 6-2. Presetting Tubing Sleeve

- (e) Then, tighten the nut an additional one turn past the ring grip point.
- (f) Unscrew nut and remove the tubing from the mating fitting, or presetting tool. Inspect the preset as described in Figure 6-1.
- (g) When installing a preset tubing assembly, lubricate the threads and seat of the fitting and the shoulder of the sleeve with a small amount of good grade lubricant such as clean compressor oil.



At installation of tubing assemblies, do not overtighten tubing nuts.

- (h) Insert tubing assembly into fitting and tighten nut until a sharp rise in torque is felt. Starting at position of sharp torque rise, tighten the nut 1/4 additional turn to complete the assembly.

NOTE

At the point where the torque starts to rise, the sleeve and tubing are just touching the seat. An additional 1/4 turn produces a seal with the fitting and restores the bow to the sleeve.

- (3) Replace damaged or defective fittings.

6-4. DISASSEMBLY OF MAJOR COMPONENTS.

Limit disassembly of major components to the extent necessary to repair or replace a given assembly. All major components are covered in the following paragraphs. Refer to Figure 8-1 for major components and their attaching hardware.

NOTE

Unless otherwise specified, all figures referenced in this section will be found in Section VIII, Illustrated Parts Breakdown.

NOTE

Remove tubing and hose assembly as needed (see Figure 6-1) in the disassembly process. Tag tube and hose assembly for reassembly purposes.

NOTE

Remove tubing clips as needed, tag clips for aid in the reassembly process.

6-5. AIR PURIFICATION/DEHYDRATOR GROUP. To remove the air purification/dehydrator group from the air compressor unit, see Figure 8-1 and proceed as follows:

NOTE

Identify all disconnected or removed tube assemblies for reassembly purposes.

NOTE

Remove tubing clips as needed for disassembly purposes.

a. Disassembly. Air purification/dehydrator group, see Figure 8-2 and proceed as follows:

- (1) Disconnect the rupture disc to tee tube assembly (1) at tee (13). Disconnect 4th stage cooler to mechanical filter tube assembly (2) at elbow (16), and mechanical filter to drain valve tube assembly (3) at elbow (17).
- (2) Disconnect ten-micron filter to service valve tube assembly (9) at elbow (26).
- (3) Disconnect and remove tube assemblies (4, 5, 6, and 8).

NOTE

Prior to removal, number cylinders (19, 22, 23, 24 and 25) as shown (Figure 8-2) for reassembly purposes.



Do not interchange or mix filter cartridges in cylinder (19, 22, 23, 24 and 25). Contaminated air would result from the mixing of cartridges.

- (4) Remove nuts (10), screws (12) and washers (11) from mounting brackets of mechanical filter (18) and cylinders (19, 22, 23, 24 and 25).
- (5) Remove tee (13), check valve (14), nipple (15) and elbows (16, 17) from the mechanical filter (18).

- (6) Remove elbows (17) from cylinder (19, 22, 23, 24 and 25). Unscrew and remove priority valve (20) and nipple (21) from cylinder (22). Unscrew and remove the ten-micron filter (29) and adapter (27) from cylinder (25).

b. Cleaning. Refer to paragraph (6-3.a for general cleaning instructions.

c. Inspection. Refer to paragraph 6-3.b for general inspection requirements. Specific assembly inspection/testing as follows.

(1) Test the priority valve (20, Figure 8-2) as follows:

- (a) Screw a 1/8 npt pipe plug in one side of valve body (12, Figure 8-5). Install priority valve to be tested in test setup shown in Figure 0-3, or equivalent.

NOTE

Hydrostatic tester may be used in lieu of air or nitrogen.

- (b) Close bleed valve and open shut-off valves. numbers one and two.
- (c) Adjust regulator, increasing pressure to tile inlet side of the priority valve assembly under test, until air escapes from priority valve outlet port.

NOTE

Gauge should indicate 2,200 + 100 psi (5,158 + 690 KPa). If indication is correct, proceed to step (g). Otherwise, proceed with step (d).

- (d) Remove priority valve assembly from test setup if specified limit is not obtained as specified in step (c) of this paragraph.
- (e) Rotate adjusting screw (2, Figure 8-5) in or out as may be required.
- (f) Re-install priority valve assembly in test setup and repeat steps (a) through (c). Repeat steps (d) and (e) until desired indication is obtained.
- (g) Close shut-off valve number two (Figure 6-3) and remove leakage apparatus.

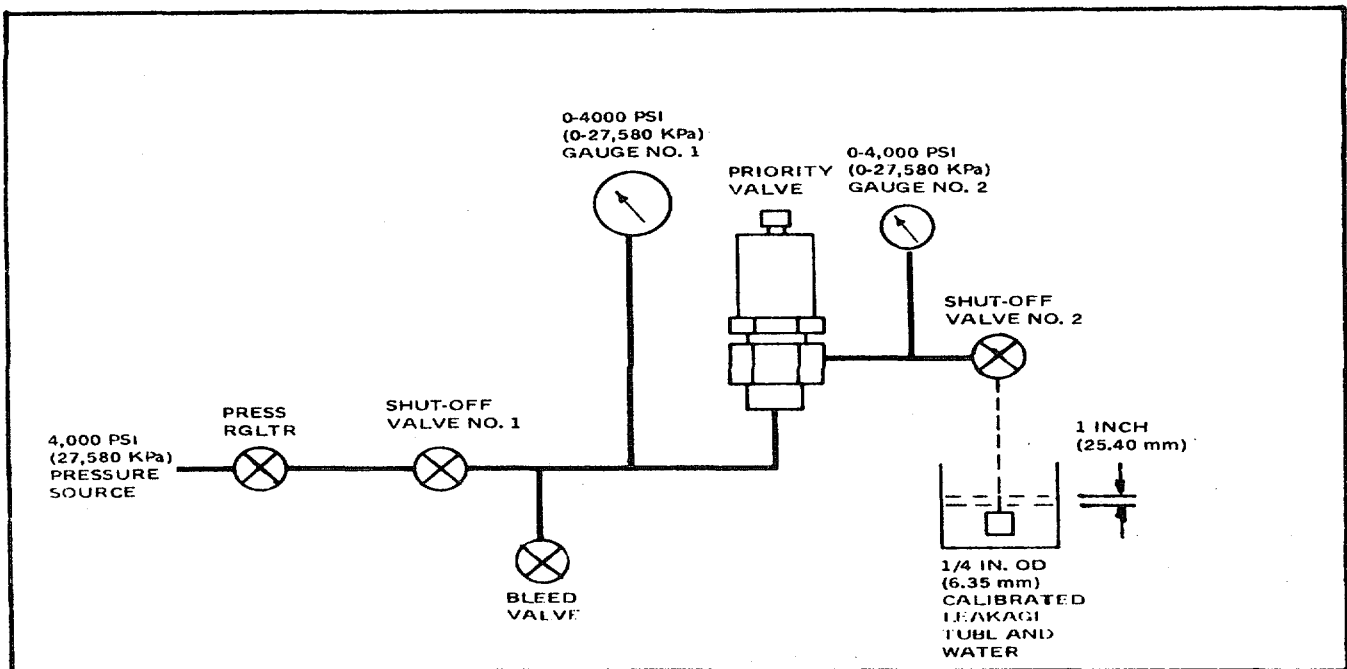

Figure 6-3. Priority Valve Test Setup

- (h) Open pressure regulator until gauge indicates 2,200 + 100 psi (15,158 ± 690 KPa).
- (i) Close shut-off valve number one.
- (j) Open shut-off valve number two to relieve the outlet pressure.
- (k) Reconnect leakage apparatus.

NOTE

The priority valve assembly should reseal when air escape ceases. Reseal pressure will be indicated on pressure gauge number one and should not be less than 200 psig (1,380 KPa).

- (l) Cycle the priority valve assembly through test procedures specified in steps (a) through (j) and check for leakage.
- (m) Cycle the priority valve assembly through test procedures specified in steps (a) through (e) and check for leakage.
- (n) If priority valve is defective, refer to PRIORITY VALVE ASSEMBLY (Section V) and repair valve.

d. Repair or Replacement. This paragraph contains information necessary to repair and replace worn or defective parts prior to assembly.

- (1) Minor nicks, scoring or scratches on non-critical surfaces may be smoothed with crocus cloth per Federal Specification P-C458.
- (2) Replace all o-rings removed during disassembly.
- (3) Replace all threaded parts having worn, stripped or damaged parts.
- (4) Replace identification markings or plates if markings are illegible.

c. Assembly. To assemble the air purification/dehydrator group, proceed as follows (see Figure 8-2):

NOTE

Assure that o-rings (32) are in place in the ten-micron filter before adaptors (31) are installed.

- (1) Assemble elbows (17) to cylinder (19, 22, 23, 24 and 25). Screw in nipple (21) in priority valve (20) and assemble to cylinder (22). Screw in adapter (27) into ten-micron filter (19) and attach to cylinder (25).
- (2) Assemble nipple (15), check valve (14), tee (13), and elbows (17, 16) on mechanical filter (18).
- (3) Position mounting brackets and attach mechanical filter (18) and cylinder (19, 22, 23, 24 and 25) using screws (12), washers (11) and nuts (10) to control panel.

NOTE

Elbows should be positioned as shown in Figure 8-2 on the mechanical filter and cylinders.

NOTE

Do not completely tighten screws (12) and nuts (10) until tube assemblies have been installed.

- (4) Assemble tube assemblies (4, 5, 6, 7 and 8) to cylinders.
- (5) Install tube assembly (9) at elbow (26), tube assembly (3) at elbow (17), tube assembly (2) at elbow (16) and tube assembly (1) at tee (15).

6-6. Mechanical Filter Assembly (See Figure 8-3). The following paragraphs contain disassembly, cleaning, inspection, repair or replacement and assembly instructions for the mechanical filter assembly.

a. Disassembly. Disassemble the mechanical filter assembly only to the extent necessary to repair or replace a defective part or parts.

- (1) Remove tee (13, Figure 8-2), check valve (14), nipple (15) and elbows (16, 17) from filter (18). Reassemble as required.
- (2) Unscrew and remove filter element and head (3) subassembly from cylinder head (7).
- (3) Remove o-ring (4) from cylinder (7).

NOTE

Perform step (4) only when o-ring (6) is damaged and replacement is necessary.

- (4) Remove cylinder tail piece (5) and o-ring (6) from cylinder (7).

b. Cleaning. Thoroughly clean the inside of the filter cylinder. Use a lint-free cloth and hot water and detergent solution per Federal Specification P-D-220. Allow cylinder to air dry.

c. Inspection. Refer to paragraph 6-3.b. for general inspection.

d. Repair and Replacement.

- (1) Minor nicks, scoring or scratches on shaft may be smoothed with crocus cloth, per Federal Specification P-C458.
- (2) Replace all parts that are worn or damaged to an extent that will impair their normal function.

e. Assembly. To assemble the mechanical filter assembly, proceed as follows:

- (1) If the cylinder tail piece (5) was disassembled, place new o-ring (6) in position and assemble tail piece (5) securely in cylinder (7).
- (2) Assemble o-ring (4) in position on element and head (3) and install the subassembly (3) in cylinder (7). Tighten securely.
- (3) Attach brackets (2, 1) to cylinder (7) until ready for next higher assembly.

6-7. Air Purification/Dehydrator Cylinder Assemblies. (See Figure 8-4.)

a. Disassembly. To disassemble the air purification/dehydrator cylinder, proceed as follows:

- (1) Unscrew and remove cylinder cap and upper head subassembly (3 through 14) from cylinder (19) and cartridge (15).
- (2) Remove screws (4), gaskets (5) and dust cover (3) from cap (7).
- (3) Remove retaining ring (6) and separate upper head (9) from cap (7). Remove o-ring (8) from cap (7).
- (4) While holding the upper head (9) and head spring (14), remove retaining screw (10) and disassemble upper perforator (11), lower head (12), head spring (14) and remove o-ring (13).

NOTE

Perform step (5) only when necessary to disassemble lower perforator (17).

- (5) Remove retainer screw (16), lower perforator (17), and spacer (18) from cylinder (19).

b. Cleaning. Refer to paragraph 6-3.a. for general cleaning instructions.

- (1) Flush the cylinder clean with P-D-680, Type II, or equivalent.
- (2) Clean the upper head with the flushing agent.
- (3) Allow the cylinder, head and parts to air dry until odor of the flushing agent disappears.

c. Inspection. Refer to paragraph 6-3.b. for general inspection procedures.

- (1) Perforator blades (11 and 17) for any bending or dullness.

- (2) Spring (14) for breaks or set,

d. Repair or Replacement. Refer to paragraph 6-3.c. for general repair or replacement procedures.

- (1) Replace a damaged cap or cylinder. Damaged threads may cause leakage.
- (2) Replace damaged or dull perforators. Defective perforators will not puncture cartridge.
- (3) Replace a defective spring.
- (4) Replace all parts that are worn or damaged to an extent that will impair their normal function.

e. Assembly. To assemble the air purification/dehydrator cylinder assembly, proceed as follows:

- (1) Assemble spacer (18) and lower perforator (17) in bottom of cylinder (19) with screw (16) tightened securely.
- (2) To assemble upper head assembly place o-ring (13) in position on lower head (12). Place o-ring (8) in position on upper head (9). Assemble spring (14) and lower head (12). Assemble spring (14) and lower head (12) on upper head (9), position upper perforator (11) and secure with screw (10).

- (3) Install this assembled group of parts in cylinder cap (7) and Install retaining ring (6). Attach cover (3) to cap (7) with screw gaskets (5) and screws (4).
- (4) Install cartridge (15) in cylinder (19) and screw tile tipper head assembly securely onto cylinder (19) hand tight.
- (5) The upper and lower mounting brackets (2 and 1) are supplied with a dehydrator assembly. Attach the brackets (2 and 1) to cylinder (19) until ready for next higher assembly.

6-8. Priority Valve Assembly (See Figure 8-5). The following paragraphs contain disassembly, cleaning, inspection, repair or replacement and assembly instructions for the priority valve.

a. Disassembly. Disassemble the priority valve only to the extent necessary to repair or replace a defective part or parts.

- (1) Unscrew and remove jam nut (1) and set screw (2) from valve housing (3).
- (2) Carefully unscrew and remove housing (3) from valve body (12).
- (3) Remove two spring buttons (4), spring (5) and valve plunger (6).
- (4) Remove backup ring (7) and o-ring (8) from plunger (6).
- (5) Remove tubing elbow (9), valve washer (10) and valve seat (11) from body (12).

b. Cleaning. Refer to paragraph 6-3.a. for general cleaning requirements.

- (1) Clean all unpainted metal parts using cleaning solvent that is in accordance with Federal Specification P-D-680, Type II or equivalent.
- (2) Wipe ion-metallic parts with a clean lint-free cloth moistened in detergent and water, and air dry.

c. Inspection. Refer to paragraph 6-3.b. for general inspection requirements. Visually inspect for:

- (1) Valve plunger for nicks and burrs that would cause sticking.

- (2) Back-up ring and o-rings for cuts, excessive wear, or deformation.

d. Repair or Replacement. Minor nicks, scoring, or scratches on non-critical surfaces may be smoothed with crocus cloth per Federal Specification P-C458. Clean up minor thread damage to threaded parts.

- (1) Replace all threaded parts having worn, stripped, or damaged threads.
- (2) Replace damaged or defective elbow.
- (3) Place new spring, plunger, backup ring, o-ring, washer, and seat from repair kit, in valve body.

e. Assembly. To assemble the priority valve assembly, proceed as follows:

NOTE

A repair kit consisting of spring (5), plunger (6), ring (7), o-ring (8), washer (10), and seat (11) is available. At overhaul of the priority valve, this kit shall be used.

- (1) Assemble valve seat (11) in valve body (12) and tap into position to full depth of bore. Install washer (10) in body (12).
- (2) Install backup ring (7) and o-ring (8) in plunger (6) groove. Assemble plunger (6) in body (12) with a twisting motion, assemble spring buttons (4) and spring (5).
- (3) Screw housing (3) onto body (12) until housing bottoms. Install set screw (2) and jam nut (1). See Figure 6-4 and install elbow (9) and plug (13) in body (12).
- (4) Set valve to open at 2,200 psig (15,158 kPa) by adjusting set screw(2); refer to AIR PURIFICATION/DEHYDRATOR GROUP, INSPECTION, paragraph 6-5.c and Figure 6-3, then tighten ,nut (1) to secure set screw at this setting.

6-9. Ten-Micron Filter Assembly. (See Figure 8-6.) The following paragraphs contain disassembly, cleaning, inspection, repair or replacement and assembly instructions for the ten-micron filter assembly.

a. Disassembly. Disassemble the ten-micron filter assembly only to the extent necessary to repair or replace a defective part or parts.

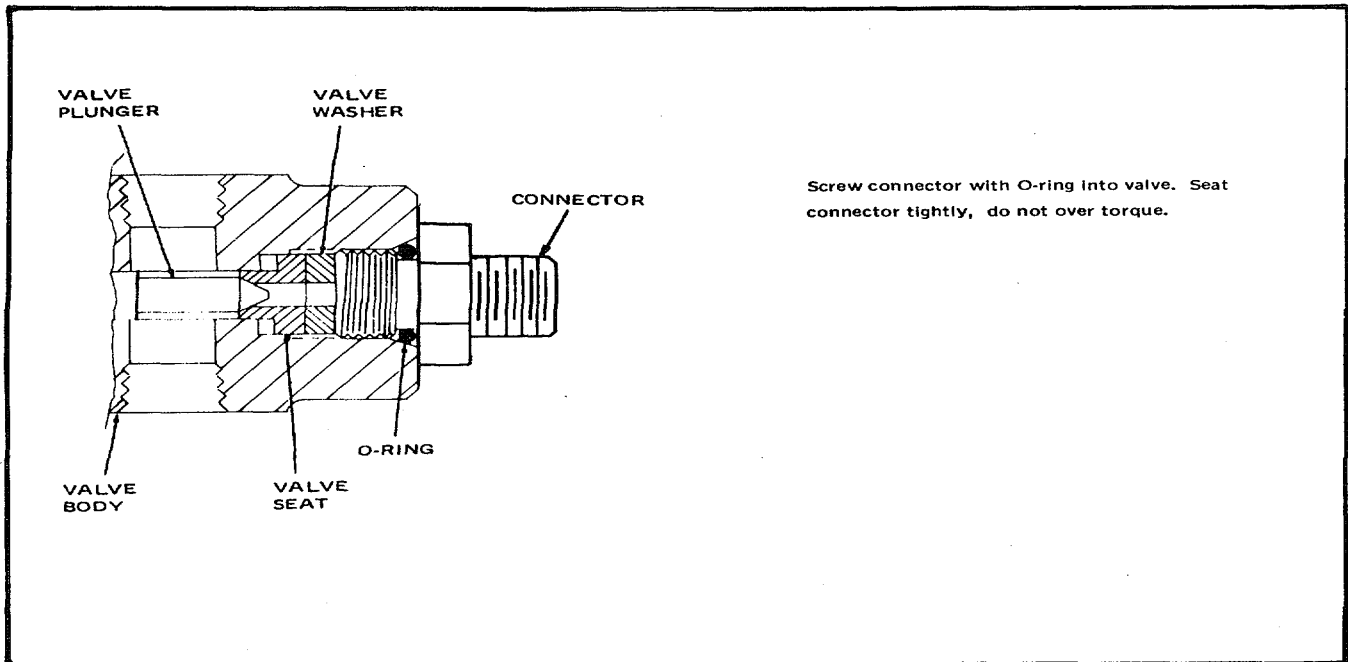

Figure 6-4. Seating Priority Valve Connector.

- (1) Unscrew and remove head (5) from bowl (1).
 - (2) Remove element (2) from bowl (1).
 - (3) Remove two backup rings (3), and o-ring (4) from filter head (5).
- b. Cleaning. Refer to paragraph 6-3.a. for general cleaning instructions.
- (1) Flush the filter bowl clean with P-D-680, Type II, or equivalent.
 - (2) Clean the filter head with the flushing agent.
 - (3) Allow bowl and head to air dry until odor of the flushing agent disappears.
- c. Inspection. Refer to paragraph 6-3.b. for general inspection instructions.
- d. Repair or Replacement. Minor nicks, scoring, or scratches on filter body surface may be smoothed with crocus cloth, per Federal Specification P-C-589. Clean up minor thread damage to threaded connections. The repair and replacement procedure for the ten micron air filter assembly is as follows:
- (1) Replace all threaded parts having worn, stripped, or damaged threads.
 - (2) Replace all parts that are worn or damaged to an extent that will impair their normal function.
- e. Assembly. To assemble the ten-micron filter assembly (Figure 8-6), proceed as follows:
- (1) Assemble the two backup rings (3) and o-ring (4) on filter head (5).
 - (2) Place filter element (2) in position and screw filter head (5) onto bowl (1).
- 6-10. Control Panel Group (See Figure 8-7). To remove the control panel group from the air compressor unit, see Figure 8-7, 8-8, 8-10, and 8-11 and proceed as follows:
- a. Disassembly. Control panel group (see Figure 8-7) and proceed as follows:
- (1) Disconnect cylinder 1 to 1st stage cooler hose assembly (1, Figure 8-39) at elbow (21, Figure 8-11). Unscrew 1st stage cooler to 1st stage trap tube assembly (2, Figure 8-39) at elbow (22, Figure 8-10).

- (2) Disconnect 2nd stage outlet to 2nd stage cooler inlet hose assembly (8, Figure 8-39) at elbow (19, Figure 8-10).
- (3) Disconnect 2nd stage air cooler outlet to 2nd stage trap tube assembly (9, Figure 8-39) at elbow (21, Figure 8-10).
- (4) Disconnect 3rd stage cooler inlet hose assembly (14, Figure 8-39) at elbow (15, Figure 8-10).
- (5) Disconnect 3rd stage outlet to 3rd stage trap tube assembly (15, Figure 8-39) at connector (13, Figure 8-10).
- (6) Disconnect 4th stage cooler inlet hose assembly (21, Figure 8-39) at elbow (11, Figure 8-11).
- (7) Disconnect and remove 4th stage cooler outlet to mechanical filter tube assembly (22, Figure 8-39) and label for reassembly purposes.
- (8) Disconnect and remove ten-micron filter to service valve tube assembly (9, Figure 8-2) at elbow (26, Figure 8-8). Label for reassembly purposes.
- (9) Disconnect drain valve to mechanical filter tube assembly (23, Figure 8-39) at the mechanical filter.
- (10) Disconnect and remove tee to drain valve tube assembly (41, Figure 8-39) at tee and drain valve to mechanical filter bleed valve tube assembly (24).
- (11) Disconnect compressor oil hose assembly (28, Figure 8-10) at elbow (10, Figure 8-8).
- (12) Disconnect engine oil pressure hose assembly (19, Figure 8-30) at connector (13, Figure 8-8).
- (13) Disconnect starter to start switch wire assembly at start switch (20, Figure 8-8).
- (14) Disconnect master switch to starter wire assembly at master switch (21, Figure 8-8) and the master switch to compressor oil pressure switch wire assembly at the master switch (21, Figure 8-8).
- (15) Disconnect ammeter to starter wire assembly at the ammeter (2, Figure 8-8).
- (16) Disconnect two wire assemblies from load switch (12, Figure 8-8) to compressor oil pressure switch, and loader switch to unloader control box at load switch (39, Figure 8-8).
- (17) Disconnect push-button-glow plug to glow plug wire assembly at push button (42, Figure 8-8).
- (18) Disconnect engine oil pressure gauge to unloader control box wire assembly at pressure gauge (9, Figure 8-8).
- (19) Remove cotter pin (2, Figure 8-19), clevis pin (3) from clevis (4). Unscrew and remove clevis (4) and nut (5) from rod (1). Remove rod (1) from control panel.
- (20) Unscrew and remove nuts, screws and tubing clips (11, Figure 8-30).
- (21) Loosen screw of wire stop (13) and pull throttle cable wire from wire stop (13).
- (22) Loosen and remove hex nut and lock washer holding throttle cable (11, Figure 8-30) against control panel at the back of the panel. Pull throttle cable (11) through the hole in the control panel. Re-install lock washer and hex nut on cable body.
- (23) Unscrew screw (1, Figure 8-10) from fan guard (5), remove rubber washers (2), special washers (3), and flat washer (4).
- (24) Unscrew and remove screws (19, Figure 8-11). Remove fan guard (5, Figure 8-10) and fan (15, Figure 8-11). Replace screws (19) in hub of compressor.
- (25) Remove nuts, washers and screws attaching the control panel assembly (Figure 8-7) to the frame. Remove control panel group from compressor frame.
- (26) Disconnect and remove rupture disc to dehydrator bleed valve tube assembly (26, Figure 8-39) at rupture disc (3, Figure 8-7). Disconnect and remove mechanical filter to rupture disc tube assembly (25, Figure 8-39) at rupture disc. Tag tubes for assembly reference.

- (27) Disconnect rupture disc to unloader control box tube assembly (27, Figure 8-39) at rupture disc. Disconnect and remove rupture disc to compressor output pressure gauge tube assembly (28, Figure 8-39). Tag tubes for assembly reference.
 - (28) Unscrew and remove nuts (4, Figure 8-7) and lockwashers (5) securing the instrument panel (6) to shock mounts (7). Remove instrument panel (6).
 - (29) Unscrew and remove nuts (2, Figure 8-9), spacers (3, Figure 8-9) and screws (1) that hold the rupture disc.
 - (30) Remove rupture disc assembly (Figure 8-9).
 - (31) Remove nuts (9) and screws (8 and 16, Figure 8-7). Remove nuts (11) and screws (10). Separate air cooler from control panel.
- b. Cleaning. Refer to paragraph 6-3.a. for general cleaning instructions.
- c. Inspection. Refer to paragraph 6-3.b. for general inspection instructions.
- d. Repair or Replacement. Refer to paragraph 6-3.c.
- (1) Minor nicks, scoring or scratches on non-critical surfaces may be smoothed with crocus cloth per Federal Specification P-C-458.
 - (2) Replace all threaded parts having worn, stripped or damaged parts.
- e. Assembly. To assemble the Control Panel Group, proceed as follows:
- (1) Position control panel on frame, support it and place air cooler (Figure 8-10) in position behind control panel. Align mounting holes. If removed, place screws (16, Figure 8-7) through bar (19). Install washers (18) on screws (16). Insert screws (16) through mounting holes and attach nuts (17). Install screws (8) and nuts (9, 11).
 - (2) Place fan guard (5, Figure 8-10) in place over compressor shaft, remove screws (19, Figure 8-11) from hub of compressor. Attach fan (15) to hub using screws (19).
 - (3) Position washers (2, 3 and 4, Figure 8-10) and fan guard (5). Using screw (1) attach fan guard (5).
 - (4) Install mounting screws (1, Figure 8-9) through control panel side, add spacers (3) and rupture disc (Figure 8-9) onto screws (1). Install nuts (2). Do not tighten rupture disc assembly at this time.
 - (5) Install instrument panel assembly (6, Figure 8-7) over shock mounts (7). Add lock washer (5) and install nuts (4). Tighten nuts.
 - (6) Connect rupture disc to unloader control box tube assembly (27, Figure 8-39) at rupture disc (3, Figure 8-7). Connect rupture disc to compressor output pressure gauge tube assembly (28, Figure 8-39).
 - (7) Connect rupture disc to dehydrator bleed valve tube assembly (26, Figure 8-39). Connect mechanical filter to rupture disc tube assembly (25, Figure 8-39). Tighten nuts (2, Figure 8-9) on screws (1).
 - (8) Assemble control panel group (Figure 8-7) to the air compressor unit frame using panel mounting nuts, washers and screws.
 - (9) Place throttle cable (11, Figure 8-30) through the throttle cable hole in the control panel from the front of the panel. Install cable body lock washer and hex nut, tighten nut.
 - (10) Install cable clips (do not tighten). Thread throttle cable wire (11) through wire stop (13, Figure 8-30). Assure that the throttle lever is in the closed position. (Throttle lever pointing toward fan belt end of engine). Tighten screw in wire stop (13). Install screws and nuts for tubing clips (11) and tighten.
 - (11) If clutch rod bushing was removed from the control panel, install and secure. Insert clutch rod (1, Figure 8-19) through bushing from the front of the panel. Install nut (5) and clevis (4) on rod end. Position clevis (4) over clutch shaft assembly (12), insert clevis pin (3) and install cotter pin (2). For clutch rod adjustment see paragraph 5-15, Section V.
 - (12) Connect engine oil pressure gauge to unloader control box wire assembly at pressure gauge (9, Figure 8-8).

- (13) Connect push button glow plug to glow plug wire assembly at push button (42).
- (14) Connect two wire assemblies from compressor oil pressure switch (8) to load switch (39) and from unloader control box to load switch (39).
- (15) Connect starter to ammeter wire assembly at ammeter (2).
- (16) Connect stator to master switch wire assembly at master switch (21), connect the compressor oil pressure switch to master switch wire assembly at the master switch (21).
- (17) Connect starter to start switch wire assembly at start switch (20).
- (18) Connect engine oil pressure hose assembly (19, Figure 8-30) at connector (13, Figure 8-8).
- (19) Connect compressor oil pressure hose assembly (28, Figure 8-10) at elbow (10, Figure 8-8).
- (20) Connect the mechanical filter and drain valve/dehydrator bleed valve to automatic drain valve tube assembly (24, Figure 8-39) at elbow (35, Figure 8-8). Connect tee to drain valve tube assembly (41, Figure 8-39).
- (21) Connect the drain valve to mechanical filter tube assembly (23, Figure 8-39) at the mechanical filter.
- (22) Connect the ten-micron filter to service valve tube assembly (9, Figure 8-2) at elbow (28) and the service valve at elbow (26, Figure 8-8).
- (23) Connect 4th stage cooler outlet to mechanical filter tube assembly (22, Figure 8-39). Connect the 4th stage cooler inlet hose assembly (21, Figure 8-39) at elbow (11, Figure 8-10).
- (24) Connect 3rd stage outlet to 3rd stage trap tube assembly (15, Figure 8-39) at connector (13, Figure 8-10). Connect 3rd stage cooler inlet hose assembly (14, Figure 8-39) at elbow (15, Figure 8-10).
- (25) Connect 2nd stage air cooler outlet to 2nd stage trap tube assembly (9, Figure 8-39) at elbow (21, Figure 8-10). Connect 2nd stage outlet to

2nd stage cooler inlet hose assembly (8, Figure 8-39) at elbow (19, Figure 8-10).

- (26) Connect cylinder 1 to 1st stage cooler hose assembly (1, Figure 8-39) at elbow (8, Figure 8-10). Connect 1st stage cooler to 1st stage trap tube assembly (2, Figure 8-39) at elbow (22, Figure 8-10).

6-11. Instrument Panel Assembly (See Figure 8-8). The following paragraphs contain disassembly, cleaning, inspection, repair or replacement and assembly instructions for the instrument panel assembly.

a. Disassembly. Disassemble the instrument panel assembly only to the extent necessary to repair or replace a defective part or parts.

- (1) Loosen and remove hour meter (1, Figure 8-8) mounting nuts and clamp. Remove the hour meter (1) from panel (44).
- (2) Loosen and remove ammeter (2) mounting nuts and clamp. Remove ammeter from panel (44).
- (3) Disconnect service pressure to service outlet tube assembly (5) at service pressure gauge elbow (7).
- (4) For the compressor pressure gauge (3), service pressure gauge (6), compressor oil pressure gauge (8) and engine oil pressure gauge (12) remove nuts and clamps on each gauge, remove gauges from the front of the panel (44).
- (5) Disconnect service outlet to service valve tube assembly (14) at service outlet (16).
- (6) Loosen and remove jam nut (15) from rear of service outlet (16). Remove service outlet (16) from panel (44).
- (7) Unscrew and remove nut securing wire assembly (17) to starter switch (20). Remove wire assembly (17) from switch post.
- (8) Remove nuts (19) and screws (18) from start switch (20). Remove the starter switch.
- (9) Loosen and remove lock nut on front of master switch (21). Remove switch (21) from rear of panel (44).

- (10) Disconnect and remove service valve to service hose bleed valve tube assembly (23). Tag for reassembly reference.
- (11) Disconnect and remove tube assembly (17) at tee (27). Disconnect and remove tube assembly (5) at tee (31). Tag for reassembly reference.
- (12) For the service hose bleed valve (29), mechanical filter drain valve (33) and dehydrator bleed valve (37) remove handles, unscrew and remove lock nuts, and remove the valves from panel (44) from the rear.
- (13) Remove retaining nut and flat washer (40) from unloader switch (39). Remove switch (39) from panel (44) from the rear.
- (14) Loosen adjusting nut at the back of the panel on push button (42). Unscrew and remove top cap from push button (42). Remove the push button from the back of the panel.
- (15) Unscrew and remove the cover of indicator (43). Remove indicator (43) from the back of the panel.

b. Cleaning. Refer to paragraph 6-3.a. for general cleaning instructions.

- (1) Clean all unpainted metal parts using cleaning solvent that is in accordance with Federal Specification P-D-80, Type II, or equivalent. Wipe nonmetallic parts with a clean, lint-free cloth moistened in detergent and water and air dry.
- (2) Clean all painted surfaces by spraying with hot water and detergent solution per Federal Specification P-D-220. Parts that will be repainted may be cleaned with steam. Avoid use of water or steam on instruments, electrical components and wiring. After cleaning, refinish affected painted areas where required in accordance with T.O.35-1-3.
- (3) Wash glass gauge faces with a soft cloth and warm soapy water or equivalent. Dry with a clean lint-free cloth. Use care not to damage indicators.



Proper precautions must be exercised to protect personnel. Stand clear of all tubing openings. After cleaning, drain tubes, and dry with

low pressure compressed air (30 psig 1207 k Pa] maximum).

- (4) Clean outside and inside surfaces of steel tubing assemblies with compressed air, pressurized hot water and detergent or steam.



Do not use steam or water to clean any electrical components or assemblies such as switches, starter motors, or solenoids.

- (5) To clean electrical components use trichloroethane, per Federal Specification O-T.620. or equivalent, and air dry parts thoroughly.

c. Inspection. Refer to paragraph 6-3.b for general inspection procedures.

- (1) Tubing for cracks, chaffing, deformation or wear.
- (2) Hexagon nuts for stripped or damaged threads.
- (3) Screws for stripped or damaged threads.
- (4) Threaded parts (fittings, etc.) for stripped or damaged threads.
- (5) Rubber grommets for cracks, excessive wear or deformation.

d. Repair or Replacement. Refer to paragraph 6-3.for general repair or replacement procedures.

- (1) Replace damaged or defective nipples, couplings and gauges.
- (2) Replace all threaded parts having worn, stripped, or damaged threads.
- (3) Replace damaged or defective tubing.
- (4) Replace damaged or defective fittings.
- (5) Replace damaged or defective pressure switch.
- (6) Replace damaged or defective lamps, switches or switch assemblies.
- (7) Replace identification plates if marking are illegible.

- (8) Straighten bent or dented panel.
- (9) Replace all parts that are worn or damaged to an extent that will impair their normal function.

e. Assembly. To assemble the instrument panel assembly, proceed as follows:

- (1) Insert indicator (43, Figure 8-8) through the back of the panel (44), assemble indicator cap on indicator and tighten.
- (2) Insert push button (42) through the back of the panel (44), install push button cap and tighten adjusting nut.
- (3) Remove retaining nut and washer from unloader switch (39), insert the switch into panel (44) from the back, install flat washer and retaining nut. Tighten nut.
- (4) Remove the handles and locknuts from hand valves (29, 33 and 37). Be sure flat washers are in place and insert hand valves through the panel from the back. Attach locknuts and handles.
- (5) Connect tube assembly (17) at tee (27) and tube assembly (5) at tee (31).
- (6) Connect service valve to service hose bleed valve tube assembly (23).
- (7) Remove locknut from master switch (21). Insert switch through back of panel (44), attach locknut to switch (21) and tighten.
- (8) Install start switch (20) in panel (44) using nuts (19) and screws (18).
- (9) Assemble wire assembly (17) to starter switch (20).
- (10) Install service outlet (16) in panel (44) using nut (15). Tighten nut.
- (11) Connect service outlet to service valve tube assembly (14) at service outlet (16).
- (12) Insert the compressor pressure gauge (3), service pressure gauge (6), compressor oil pressure gauge (8) and engine oil pressure gauge in to panel (44). Attach clamps and nuts to each gauge.

- (13) Connect the service pressure to service outlet tube assembly (5) at service pressure gauge elbow (7).

- (14) Install ammeter (2) into panel (44), attach to panel with mounting clamps and nuts.

- (15) Install hourmeter (1) into panel (44) with mounting clamp and nuts.

6-12. Rupture Disc Assembly (See Figure 8-9). The following paragraphs contain disassembly, cleaning, inspection, repair or replacement and assembly instructions for the rupture disc assembly.

a. Disassembly. Disassemble the rupture disc assembly only to the extent necessary to repair or replace a defective part or parts.

- (1) Remove rupture disc base (8) from body (10). Remove cap nut (9) from rupture disc base (8) and remove washer and rupture disc.

- (2) Remove connectors (5), elbows (4, 7) and straight tee (6).

b. Cleaning. Refer to paragraph 6-3.a. for general cleaning procedures.

c. Inspection. Refer to paragraph 6-3.b for general inspection procedures.

d. Repair or Replacement. Refer to paragraph 6-3.c for general repair or replacement procedures.

e. Assembly. To assemble the rupture disc assembly, proceed as follows:

- (1) Install straight tee (6), elbows (7, 4) and connectors (5) to body (10).

- (2) If rupture disc and washer were removed from the disc base (8) install and assemble cap nut (9) to disc base (8). Install disc base (8) in body (10).

6-13. Air Cooler Group (See Figure 8-10.) The following paragraphs contain disassembly, cleaning, inspection repair or replacement and assembly instructions for the air cooler group.

a. Disassembly. Disassemble the air cooler group only to the extent necessary to repair or replace a defective part or parts.

(1) Unscrew and remove first stage safety valve assembly (6), reducing bushing (7), tubing elbow (8), and street tee (9).

(2) Unscrew and remove fourth stage safety valve assembly (10). Remove tubing elbow (11), street tee (12), and tubing adaptors (13).

(3) From the opposite side of the cooler assembly, unscrew and remove the third stage safety valve assembly (14), elbow (15), tee (16) and elbow (17).

(4) Unscrew and remove the second stage safety valve assembly (18). Remove adaptor (19) and tee (20). Remove elbows (21 and 22)

(5) Remove six machine screws (23) and remove fan shroud (24) from air cooler (25).

b. Cleaning. Refer to paragraph 6-3.a. for general cleaning requirements.

(1) Clean outside surfaces of the air cooler with compressed air, pressurized hot water and detergent or steam.

(2) Clean inside of tubing surfaces with I'-D-80, Type II.

(3) After cleaning dry with low pressure compressed air (30 psi).

c. Inspection. Refer to paragraph 6-3.b for general inspection requirements.

(1) Test safety valves. Connect valve to be tested to a gauged and regulated 4,000 psig (27,580 KPa) air or nitrogen source. See Figure 6-5.

WARNING

Keep unprotected parts of body away from valve opening during test.

NOTE

Hydrostatic tester may be used in lieu of nitrogen or air pressure source.

(a) with zero pressure increase pressure to valve operating pressure.

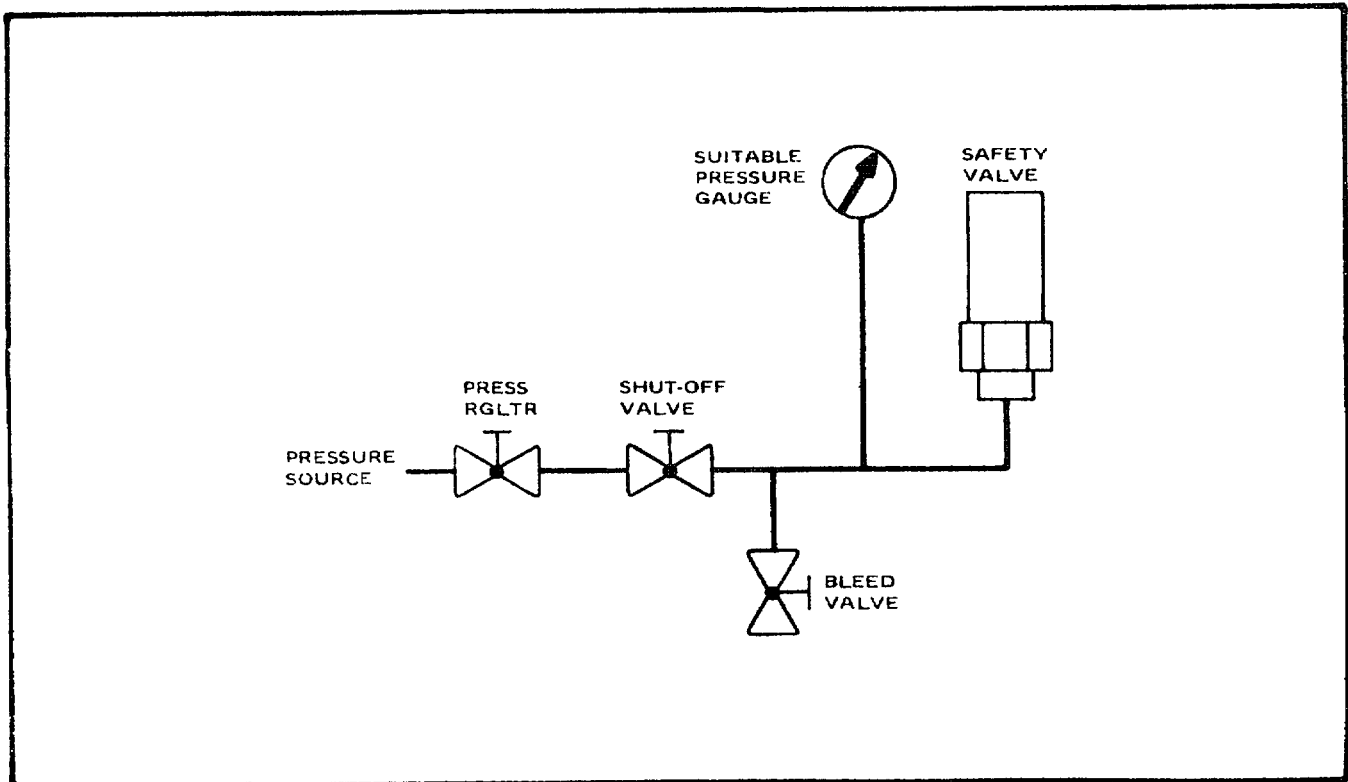

Figure 6-5. Typical Safety Valve Test Setup

1st stage valve	80 psig (552 kPa)
2nd stage valve	240 psig (1,655 kPa)
3rd stage valve	1,500 psig (10,343 kPa)
4th stage valve	3,800 psig (26,196 kPa)

Spray the tube around the fins with silicone lubricant (NSN 9150-00-823-78060).

- (b) If safety valve relieves pressure prior to or after specified pressure. replace safety valve.

- (2) Screw a steel pipe plug into first stage outlet opening. Pressurize air cooler with low pressure air (30 psig [207 kPa] maximum) at first stage inlet opening. Immerse cooler first stage in water. Inspect for any leaks.
- (3) Remove pipe plug and air source from first stage. Repeat step (1.) (a.) for second, third, and fourth stages of air cooler.
- (4) Refer to REPAIR OR REPLACEMENT to repair leaks in the air cooler.

d. Repair or Replacement. Refer to paragraph 6-3.c. for general Repair or Replacement instructions:

- (1) Replace all threaded parts having worn, stripped. or damaged threads.
- (2) Replace damaged or defective fittings.
- (3) Replace damaged or defective safety valves.
- (4) Straighten bent or dented shroud assembly. Weld any cracks or breaks.
- (5) Repair air cooler, if leaking, as follows.
 - (a) Using an oxy-acetylene torch, carefully unsolder U-bend end fitting on stub from one end of the defective tube.
 - (b) Manufacture extraction tool by using a four inch long 0. inch diameter (102 mm long, 9.525 mm diameter) solid steel rod. Solder a three inch (7.63 mm) piece of same material for t-handle. Insert tool into exposed elbow end, flared end of the defective tube, work the defective tube loose from the cooling fins.
 - (c) Rotate the tool installed in step 2, but do not exert extreme that will deform tube. If tube will not work loose, use a #6-16 blade type screw driver or other flat tool to work each cooling fin gently back and forth to relieve any oxide or corrosion.

- (d) Manufacture a new tube section and have one end swaged to proper size for resoldering of end piece.

NOTE

Use a piece of asbestos cloth or other heat shield to protect surrounding fittings from direct flame. Small pin holes can develop in the solder joints of existing fittings if they are not protected.

- (e) Ensure ends of new tube, original fittings, and all unsoldered areas are clean. Insert new tube through cooler. Use silver solder and flux, resolder new tube and original fittings back into place.
- (f) After soldering is finished, test the cooler with low pressure air and water, refer to INSPECTION to determine if any leaks are present. If leaks are present, resolder where necessary. Check the cooling stages to the proper pressure for each with water or hydraulic pressure. If hydraulic pressure is used, be sure the tubes are purged of hydraulic fluid before repainting and re-use.

e. Assembly. To assemble the air cooler group, proceed as follows:

- (1) Using six screws (23) attach fan shroud (24) to (cooler (25).
- (2) Assemble elbows (22, 21), tee (20) to cooler (25). Assemble adapter (19) and safety valve (18) to tee (20).
- (3) Assemble elbow (17) to cooler (25), assemble tee (16) to elbow (17) and elbow (15) and safety valve (14) to tee (16).
- (4) On the opposite side of the cooler assembly, install tubing adapter (13), tee (12) and tubing elbow (11). Assemble safety valve (10) with tee (12).
- (5) Assemble street tee (9), tubing elbow (8), reducing bushing (7) and safety valve (6).
- (6) Using washers (4, 3, and 2), attach guard (5) to shroud (24) using (1)

6-14. AIR COMPRESSOR GROUP (See Figure 8-11). The following paragraphs contain disassembly, cleaning, inspection, repair or replacement and assembly instructions for the air compressor group.

a. Disassembly. Disassemble the air compressor group only to the extent necessary to repair or replace a defective part or parts.

- (1) Tube/hose assembly. Refer to paragraph 6-4. Remove tube/hose assemblies as needed. Tag to identify for reassembly purposes.



Do not use a chain around cylinder heads to lift air compressor assembly.

- (2) Remove hose clamp (1, Figure 8-11) and breather hose (2).
- (3) Using a lifting sling and hoist, or other suitable equipment, support air compressor group and remove eight nuts, lock washers, and screws (18, 19, and 20, Figure 8-18) attaching compressor to clutch. Remove two screws (3), lock washers (4) and mount washers (5) attaching compressor (28) to frame.

NOTE

Block up rear end of engine assembly to support engine when air compressor assembly is removed.

- (4) Using hoist and lifting sling, back compressor (28) away from clutch until drive ring gear (76, Figure 8-12) is free of clutch driving plate (50, Figure 8-18).

NOTE

For ease of disassembly, move compressor group to a work bench or equivalent and remove hoist and lifting sling.

- (5) Unscrew and remove nut (8, Figure 8-11) and screw (9) with lockwasher (10) attaching each compressor mounting bracket (11) to frame. Remove brackets (11) from frame.
- (6) Separate and remove shock mounts (6)

from compressor mounts (11).

- (7) Remove screw (13) and washer (14), fan hub washer (12), and nuts (17), washers (18), and screws (19) from fan (15) and hub (16). Remove fan (15) and key (20) from compressor (28).
- (8) Remove elbow (21) from first stage cylinder head and elbow (22) from second stage cylinder head.
- (9) Remove one elbow (23) from second stage cylinder head, two elbows (23, 24) from third stage cylinder, and two elbows (24) from fourth stage cylinder head.
- (10) Remove hose clip (25) and hose (27). Remove hose clamp (25) and PVC valve (26) from breather hose (27).

b. Cleaning. Refer to paragraph 6-3.a for general cleaning instructions.

- (1) Clean all unpainted metal parts using P-D-680, Type II or equivalent. Wipe non-metallic parts with a clean, lint-free cloth moistened in detergent and water. Air dry.
- (2) Clean outside and inside surfaces of steel tubing with compressed air, pressurized hot water and detergent or steam.
- (3) Clean exterior of hoses in soap and water. Wipe dry.

c. Inspection. Refer to paragraph 6-3.b for general Inspection instructions.

d. Repair or Replacement. Refer to paragraph 6-3.c for general repair instructions.

e. Assembly. To assemble the air compressor group, proceed as follows:

- (1) Assemble PVC valve (26) to breather hose (27) with clamp (25). Install breather hose (27) with clamp (25).
- (2) Install elbows (24) in fourth stage cylinder head, elbows (23, 24) in third stage cylinder and elbow (23) in second stage cylinder.
- (3) Install elbow (22) in second stage cylinder head and elbow (21) in first stage cylinder head.

- (4) Install key (20) and hub (16) on compressor crankshaft (28). Attach fan (15) to hub (16) using nuts, washers and screws (17, 18 and 19). Insert hub washer (12) and install washer (14) and screw (13).
- (5) Attach compressor mount (11) to frame using nuts, washers and screws (8, 9, and 10).
- (6) If removed, assemble shock mounts (6) to compressor mount (11).



Do not use a chain around cylinder heads to lift compressor assembly.

- (7) Using a lifting sling and hoist, position compressor assembly on chassis and align compressor drive ring gear teeth with teeth on clutch drive plates.
- (8) Using screws (3), lock washers (4) and mounting washers (5) secure compressor to compressor mounts.
- (9) Make certain clutch is engaged. Attach clutch housing to compressor using nuts, washers and screws (20, 19, and 18).
- (10) Connect tube and hose assemblies.
- (11) Connect air compressor breather hose (2) using hose clamp (1).

6-15. Air Compressor Assembly. (See Figure 8-12). The following paragraphs contain disassembly, cleaning, inspection, repair or replacement and assembly instructions for the air compressor assembly.

a. Disassembly. Disassemble the air compressor assembly only to the extent necessary to repair or replace a defective part or parts.

- (1) Remove screws and lock washers (2, 3) from air cleaner (1) base. Remove air cleaner (1) and gasket (4).
- (2) Loosen hose clamps (12), remove crankcase filter (7), hose (11), hose clamps (12). Unscrew and remove nipple (13).
- (3) Pull oil dipstick bayonet gauge (15) out of guide and remove o-ring (16). Unscrew

and remove dipstick guide (17), pipe elbow (14), pipe tee (18) and pipe nipple (19).

- (4) Remove oil pump to oil filter tube subassembly (20) between oil pump and oil filter mounting bracket (52). Remove the tubing adaptor (21) and tubing elbow (22).
- (5) Remove oil filter-to-oil pump tube subassembly (23) between oil filter mounting bracket (52) and oil pump. Remove two tubing adaptors (24).
- (6) Remove third stage cylinder-to-oil sump hose subassembly (25) between third stage cylinder and oil sump. Remove tubing elbow (26).
- (7) Remove fourth stage cylinder-to-oil sump hose subassembly (27) between fourth stage cylinder and sump. Remove tubing elbow (33), and tubing tee (28).
- (8) Remove fourth stage cylinder-to-oil pump hose subassembly (29) between oil pump and fourth stage cylinder. Remove tubing elbow (31).
- (9) Remove oil pump-to-oil sump hose subassembly (32) between oil pump and sump. Remove two tubing elbows (33).
- (10) Remove oil sump-to-oil pump hose subassembly (35) between oil sump and oil pump. Remove tubing adaptor (36), from oil pump.
- (11) Remove adaptor (37) from end cover (90), and remove elbow (33) from oil strainer (120).
- (12) Unscrew reducer bushing (39) from elbow (40) and remove elbow (40) from oil sump (121). Remove pipe plug (41) from end cover (90).
- (13) Remove tubing adaptor (42), reducing bushing (43) and piston (44) from end cover (90). Remove oil relief screw (45), locknut (46), gasket (47), relief spring (48), and oil relief ball (49) from end cover (90).
- (14) Unscrew and remove oil filter (50) and adaptor (51). Remove two cap screws (53), lock washers (54) and remove the oil filter mounting bracket (52) from second stage cylinder head.

- (15) Rotate crankshaft positioning the first stage piston at top dead center. Unscrew and remove the four locknuts (56) and carefully lift first stage head and cylinder group (55) away from crankcase (127) far enough to expose piston pin retaining rings (59). Remove the retaining rings (59) and piston pin from piston and the connecting rod. Keep piston pin and piston with first stage cylinder and piston group. Remove cylinder gasket (58). Studs (57) need not be removed from crankcase unless damaged and require replacement.
- (16) Rotate crankshaft positioning the second stage piston top dead center. Unscrew and remove four locknuts (61) and carefully lift second stage head and cylinder group (60) away from crankcase (127) far enough to expose piston pin retaining ring (64). Remove the retaining rings (64) and the piston pin from piston and connecting rod. Keep piston pin and piston with second stage cylinder and piston group. Remove cylinder gasket (63). Studs (62) need not be removed from crankcase unless damaged and require replacement.
- (17) crankshaft positioning the third stage piston top dead center. Unscrew and remove four locknuts (66) and carefully lift third stage head and cylinder group (65) away from crankcase (127) far enough to expose piston pin retaining rings (69). Remove the retaining rings (69) and the piston pin from the piston and connecting rod. Keep piston pin and piston with third stage cylinder and piston group. Remove cylinder gasket (68). Studs (67) need not be removed from crankcase unless damaged and require replacement.
- (18) Rotate crankshaft positioning the fourth stage piston top dead center. Unscrew and remove four locknuts (71) and carefully lift fourth stage head and cylinder group (70) off crankcase (127). Remove cylinder gasket (73). Studs (72) need not be removed from crankcase unless damaged and need replacement. Remove piston pin retaining rings (74) and piston pin from piston and connecting rod.
- (19) Remove six cap screws (77), lock washers (78) and drive ring (76). Remove three cap screws (80), lock washers (81) and flywheel (79). Dowel pin (82) need not be removed unless replacement is necessary. Remove flywheel gasket (83).

NOTE

Pay particular attention to disassembly sequence of oil seal (88) from crank (118). (See Figure 6-6.) Reference sequence for reassembly purposes. Care should be taken not to mar T-seal surface and the o-ring seal finished surface.

- (20) Remove four locknuts (85) and sealing washers (86) and remove the oil seal cover (84). Remove o-ring (87), oil seal (88) and oil pump outer cover (89).
- (21) Remove cap screws (91, 93) and lock washers (92, 94), separate and remove end cover assembly (90) and remove gasket (95). Disassemble cover bushings (96) and o-ring (97) from end cover (90) only when replacement is necessary.
- (22) Remove the four oil pump blades (99), The oil pump rotor (98) and rotor key (100) from crankshaft (118). Remove the oil pump inner cover (101) and four cover studs (102). Press oil seal (103) out of cover (101).

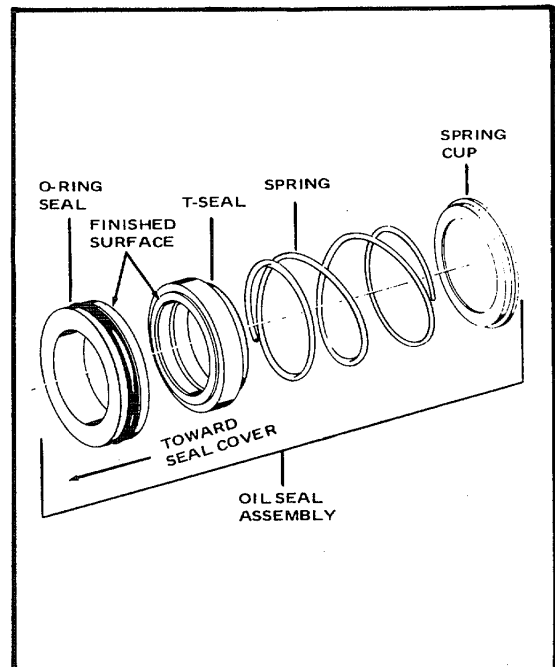

Figure 6-6. Oil Seal, Crankshaft

(13) Support the crankshaft with suitable wooden blocks and remove live cap screws (105), one cap screw (107), lock washers (106, 108), separate and remove drive end cover (104) from crankcase (127). Remove gasket (109). Press oil seal (110) out of end cover (104).

(24) Use a bearing puller, remove the two crankshaft bearings (111) from each end of crankshaft (118). Remove two cap screws (113) and lock washers (114) from each of the two balance weights (112) and remove the balance weights (112) from crankshaft (118).

(25) Carefully lift crankshaft off supporting blocks and withdraw from crankcase, removing the connecting rod assemblies (115, 116, and 117) from crankshaft journal as crankshaft is being withdrawn. Do not remove pipe plug (119) from crankshaft (118) except for cleaning of oil passages. or for replacement because of leakage.

(26) Unscrew and remove oil strainer (120) from sump (121). Remove three cap screws (122) and lock washers (123), remove oil sump (121) and o-ring (124). Do not remove tapping screws (126) and serial number plate (125) from crankcase (127) unless replacement of the plate or crankcase is necessary due to damage. When replacing serial number plate (125), make certain all data from old plate is stamped on new to retain same serial number for service records.

b. Cleaning. Refer to paragraph 6-3.a for general cleaning requirements.

(1) Clean all painted surfaces by spraying with hot water and detergent solution per Federal Specification P-D-220.

(2) Parts that will be repainted may be cleaned with steam. Avoid use of water or steam on instruments, electrical components, and wiring.

(3) After cleaning, refinish affected painted areas where required in accordance with T.O.34-1-3.

(4) Remove caked grease or dirt with a nonmetallic brush after immersing part in solvent.

Scrape carbon, grease, and old gasket material from affected surfaces.

(5) Clean compressor cylinders and pistons with care. Do not use wire or scratch contact or seating surfaces. Piston ring grooves must be cleaned with care so as not to scratch or mar grooved surfaces. Use a

section of old piston ring corresponding to groove size for this purpose.



Do not immerse in dry cleaning solvent prior to installation.

(6) Clean bearings by immersing them in dry cleaning solvent per Federal Specification P-D-680, Type II, and air dry.

c. Inspection. Refer to paragraph 6-3.b. for general inspection requirements. Refer to Table 6-1, Table of Limits for dimensional inspections.

d. Repair or Replacement. Refer to paragraph 6-3.c. for general repair or replacement requirements.

(1) Replace oil seal, gaskets, and preformed o-ring packing.

NOTE

Minor nicks, scratches, and burrs may be honed with a fine hand stone.

(2) Replace cylinders having cracks, broken fins, damaged or warped mating surfaces, and if tolerances given in Table 6-1 (Table of Limits) are not met.



Do not remove any more material than is necessary to completely remove the glaze. Clean the cylinders in accordance with CLEANING instructions.

(3) Remove glaze from cylinder walls with portable cylinder hone (using 280 to 400 grit stones), a glaze breaker, or a crocus cloth, depending on condition of cylinder walls.

(4) Replace pistons if worn, cracked, scored, scuffed, and if ring lands are worn or broken.

NOTE

If a piston is found to be defective, replace piston and piston pin as an assembly.

- (5) Replace pistons and piston pins not meeting the tolerances given in Table 6-1 (Table of Limits).
- (6) Replace all damaged piston rings.



The connecting rod bearings shall be replaced, regardless of apparent condition, at the end of each 10,000-hour operating period.

- (7) Replace oil pump blades if blades are worn, chipped, cracked or broken. Replace entire oil pump if parts other than blades require replacement.
- (8) Replace damaged or defective oil strainer.
- (9) Replace end covers if worn, cracked, chipped, or warped. Remove minor burrs with a fine hand stone.
- (10) Replace crankshaft bearings if worn, scored, or damaged in any way that will impair their normal function.
- (11) Replace crankshaft having worn, scored, pitted, or out of round journal or bearing surfaces, permanently restricted oil passages, and if tolerances given in Table 6-1 (Table of Limits) are not met.
- (12) Replace crankcase if cracked or if mating surfaces are damaged or warped.

NOTE

Minor nicks, scratches, and burrs may be honed with a fine hand stone.

- (13) Replace any defective cylinder.

e. Assembly. To assemble the air compressor assembly, proceed as follows:



Do not mount oil sump (121) in a vise.

NOTE

A compressor overhaul kit consisting of all gaskets, o-ring, and oil seals is available. Replace all gaskets, seals,

and o-rings, coat gaskets and o-rings with a light coat of petrolatum, per Federal Specification VV-P-236, to aid in assembly.

- (1) Mount the oil sump (121) in a suitable holding fixture to start assembly. Assemble o-ring (124) in groove on sump. Assemble crankcase (127) to sump (121) and attach with three lock washers (123) and screws (122). If removed, attach serial number plate (125) to crankcase with screw (126). Assemble oil strainer (120) in sump.
- (2) If pipe plug (119) was removed from crankshaft (118) install the pipe plug (119). Place connecting rods (115, 116, and 117) in crankcase (127) with rod bearing ends through crankcase cylinder bores.
- (3) Assemble balance weight (112) to drive end of crankshaft (118) bearing journal with lock washers (114) and cap screws (113).
- (4) Heat drive end bearing (111) by immersing in oil heated to temperature of 350°F (177°C). Allow bearing to heat from five to ten minutes; then, assemble on crankshaft drive end journal with bearing inner race against shoulder of balance weight (112)
- (5) Assemble a new oil seal (110) in bore of drive end cover (104) flush with outer face and with sealing lip facing inward. Press three dowel pins (77) in end of crankshaft (118) leaving approximately half of pin protruding from crankshaft. Carefully assemble drive end cover (104) over bearing (113). Place new gasket (109) against end cover (104) flange aligning holes. Insert non-drive end of crankshaft (118) through drive end of crankcase and carefully through the connecting rods (115, 116, 117). Secure drive end cover (104) to crankcase (127) with lock washers (106, 108), one 1-1/4 inch long cap screw (107) and five 1-1/2 inch long cap screws (105).
- (6) Assemble drive ring gear (76) to flywheel (79) with lock washers (78) and cap screws (77). position flywheel gasket (83) on end of crankshaft over dowel pin (82) and carefully assemble flywheel (79) to end of crankshaft (1 18) with three lockwashers (81) and socket head cap screws (80).

(7) Assemble balance weight (112) to non-drive end of crankshaft rod journal with lock washers (114) and cap screws (113). Heat the non-drive end bearing (111) by immersing in oil heated to temperature of 350°F (177°C). Allow bearing to heat from live to ten minutes; then, assemble (01 crankshaft journal with inner race against shoulder of balance weight.

(8) See Figure 6-7. Using rear pump cover and seal tool (Table 2-1), assemble new oil seal (103), with seal lip facing towards bearing, onto crankshaft (118). Install four studs (102) in oil pump inner cover (101) with short threaded end in cover (101). Assemble cover (101) on crankcase. Install pump rotor key (100) in (118) keyway. Assemble oil pump rotor (98) over key (100) and install pump blades (99). Remove cover and seal tool.

(9) If end cover assembly (90) was disassembled, press in one bushing (96) to a depth of 1.3201.330 inch from face of boss on side of end cover (90), install o-ring (197), then press in the other bushing (96) to a depth of 0.780 0.790 inch from boss face. Position gasket (95) on flange of end cover (90) and assemble end cover to crankcase with oil relief valve boss located 90° from top, facing compressor non-drive end and aligning studs

(102) with end cover holes. Secure end cover (95) to crankcase with lock washers (92, 94) and screws (91, 93). Install oil pump outer cover (89) with chamfered side of bore facing outward and drilled oil passage 111 the 12 o'clock position over studs (102).



Assure that finished surface of o-ring seal is against (facing inward) T-seal surface. Care should be taken not to mar T-seal surface or o-ring seal finished surface. (See Figure 6-6).

(10) Install spring cup and spring of oil seal (88) over crankshaft (118), place T-seal of oil seal (88) over crankshaft (118) and into spring. Place o-ring seal of oil seal (88) over crankshaft (118) with finished surface inward. Assemble o-ring (97) on cover (84), assemble cover (84) over crankshaft onto studs (102) and secure with washers (86) and nuts (85).

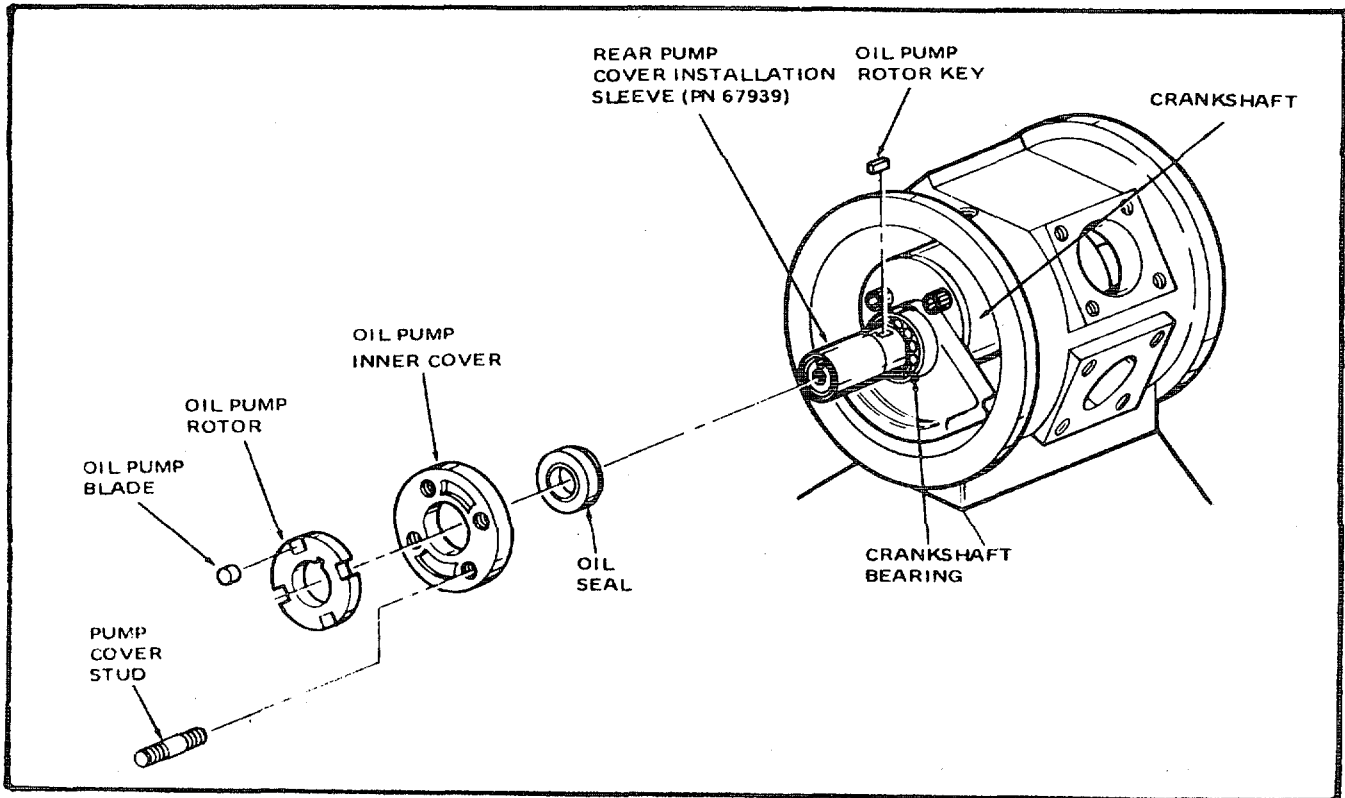

Figure 6-7. Non Drive End Cover, Oil Pump and Oil Seal Installation

- (11) If removed, assemble cylinder studs (57, 62, 67, and 72) in crankcase (127) (12) Place gasket (73) over cylinder studs (72), assemble fourth stage piston assembly (Figure 8-17) to connecting rod (115) with fourth stage piston pin (7, Figure 8-17) pushed through piston and rod (115, Figure 8-12) and secure with two retaining rings (79). Lubricate piston rings (2, Figure 8-17) with clean compressor oil and carefully assemble cylinder (Figure 8-18) over fourth stage piston assembly (Figure 8-17). Assemble the fourth stage cylinder (70) to crankcase (127), secure with heavy duty locknuts (71).
- (13) Place gasket (68) over cylinder studs (67). Remove piston pin (Figure 8-16) from third stage piston, position piston over connecting rod (115, Figure 8-12) and assemble piston to connecting rod by pushing piston pin through piston and rod and securing pin in position with retaining rings (69). Carefully assemble cylinder (16, Figure 8-16) over piston with air outlet (on side of cylinder head) facing non-drive end of compressor. Secure cylinder (16) to crankcase with heavy duty locknuts (66, Figure 8-12).
- (14) Place gasket (63) over cylinder studs (62). Remove piston pin from second stage piston (1, Figure 8-15). Position piston over connecting rod (116) and assemble piston to rod by pushing piston pin through piston and rod. Secure piston in position with retaining rings (64). Carefully assemble cylinder (17, Figure 8-15) over piston (1) with air outlet (on side of cylinder head) facing non-drive end of compressor. Secure cylinder (17) to crankcase with heavy duty locknuts (61, Figure 8-12). Mount oil filter mounting bracket (52) and secure to head and cylinder (60) with two lock washers (54) and two 1-3/4 inch long cap screws (53). Tighten all eight head cap screws to 20 pounds foot. Install adapter (51) and compressor oil filter (50) on mounting bracket (52).
- (15) Place gasket (58) over cylinder studs (57). Remove piston pin from first stage piston (1, Figure 8-14); position piston over connection rod (117) and assemble piston to rod by pushing pin through piston and rod. Secure piston pin in position with retaining rings (59). Carefully assemble cylinder (17, Figure 8-14) over piston (1) and with air outlet in head facing down and secure to crankcase with heavy duty locknuts (56, Figure 8-12).
- (16) Assemble oil relief ball (49), relief spring (48), gasket (47), locknut (46), and oil relief screw (45) in end cover (90). Assemble piston (44), reducing bushing (43), and adaptor (42) in end cover (90). Assemble pipe plug (41) in end cover (90).
- (17) Screw street elbow (40) into oil sump (I 21) oil drain. Assemble reducer bushing (39) to elbow (40). Screw elbow (33) into oil strainer (120). Install one reducer bushing.
- (18) Install adapters (37 and 36) in end cover (90). Connect oil sump-to-oil pump hose (35) between elbow (33) in oil strainer (120) and adapter (36) in end cover (90).
- (19) Install one elbow (33) in end cover (90) and one elbow (33) in oil sump (121). Connect oil pump-to-oil sump hose (32) between elbow (33) in end cover (90) and elbow (33) in oil sump (121).
- (20) Install one elbow (30) in fourth stage cylinder (70) and one elbow (39) in end cover (90). Connect fourth stage cylinder-to-oil pump hose (29) between elbow (30) in fourth stage cylinder (70) and elbow (31) in end cover (90).
- (21) Install tee (28) in air sump (121) and elbow (33) in fourth stage cylinder (70). Connect fourth stage cylinder-to-oil sump hose (27) between elbow (37) in fourth stage cylinder (76) and tee (20) in oil sump (121).
- (22) Install elbow (26) in third stage cylinder (65). Connect third stage cylinder-to-oil sump hose (25) between elbow (26) in third stage cylinder (65) and tee (28) in oil sump (121).
- (23) Screw one adapter (24) into boss on end cover (90) and one adapter (24) into boss on filter mounting bracket (52). Connect oil filter-to-oil pump tube (23) between adapter (24) in mounting bracket (52) and adapter (24) in end cover (90).
- (24) Install elbow (22) in boss on oil filter mounting bracket (52) and adapter (21) in boss on end cover (90). (Connect oil pump-to-oil filter tube (20) between adapter (21) in end cover (90) and elbow (22) in bracket (52)

- (25) Assemble pipe nipple (19) in oil sump (121); assemble pipe tee (18), street elbow (14), guide (17) to nipple (19). Place o-ring (16) on oil level gauge and install gauge (15) in nipple (19).
- (26) Assemble pipe nipple (13) in street elbow (14), attach hose (11) to nipple (13) and crankcase filter (7) with two hose clamps (12).
- (27) Install gasket (4) air breather (1) using locknuts (3) and screws (2) to 1st stage cylinder head (5, Figure 8-14).

6-16 Air Cleaner Assembly (See Figure 8-13). The following paragraphs contain disassembly, cleaning, inspection, repair or replacement and assembly instructions for the air breather assembly.

a. Disassembly. Disassemble the air cleaner assembly only to the extent necessary to repair or replace a defective part or parts.

- (1) Unscrew and remove wing nut (1) and washer (2) from top of air breather assembly.
- (2) Remove breather cover (3), element (4) and gasket (5) from base (6).

b. Cleaning. Refer to paragraph 6-3.a for general cleaning instructions.

c. Inspection. Refer to paragraph 6-3.b for general inspection instructions.

d. Repair or Replacement. Refer to paragraph 6-3.c for general repair or replacement instructions.

- (1) If spot welds should crack or break loose on the stud or stud bracket of the base (1) repair by spot welding the crack or break.

e. Assembly. To assemble the air cleaner assembly, proceed as follows: (1) Place gasket (5) on base (6), install element (4) cleaner cover (3).

NOTE

Position breather cover (3) for proper breather hose attachment prior to tightening wing nut (1).

6-17. First Stage Cylinder and Piston Group. (See Figure 6-24 8-14). The following paragraphs contain disassembly, cleaning, inspection, repair or replacement, and assembly instructions for the first stage cylinder and

piston group.

a. Disassembly. Disassemble the first stage cylinder and piston group only to the extent necessary to repair or replace a defective part or parts.

- (1) Remove the piston and pin assembly (1) with piston rings (2) from cylinder (17).

NOTE

The piston and pin (1) are matched and are not to be replaced separately. Replace as an assembly only. The compression rings (3) and oil control ring (4) are supplied in the form of a piston ring kit. Replacement of rings should be by kit set only.

- (2) Remove cap screws (6) and lock washer (7); remove cylinder heat (5) gasket (8), valve assembly (9) and gasket (16).

- (3) To disassemble valve assembly (9), remove cotter pin (11), remove castle nut, and separate upper plate from lower plate. Fixing pin need not be removed from upper plate.

NOTE

The lentoid springs (12), valve ring (13), valve plate (14), spring plates (15), and the cotter pin (11) are supplied in the form of a valve repair kit and shall be replaced as such.

- (4) Remove valve plate (14), two lentoid springs (12), valve ring (13), and two spring plates (15).
- (5) The center bolt is secured in the lower plate with dowel pin peened over and neither should be removed.

b. Cleaning. Refer to paragraph 6-3.a for general cleaning instructions.

- (1) Remove caked grease or dirt with a nonmetallic brush after immersing part in solvent. Scrape carbon, grease, and old gasket material from affected surfaces.
- (2) Clean parts with care. Do not mar or scratch contact or seating surfaces. Valve components should not be wire brushed.

c. Inspection. Refer to paragraph 6-3.b for general inspection instructions.

- (1) Parts with dimensions listed in Table 6-1, Table of Limits, shall be measured to ascertain acceptability for repair or replacement and assembly.

d. Repair or Replacement. Refer to paragraph 6-3.c for general repair or replacement instructions.

- (1) Replace all gaskets removed during disassembly.



Do not remove any more material than is necessary to completely remove the glaze. Clean the cylinders in accordance with cleaning procedures.

- (2) Remove glaze from cylinder walls with portable cylinder hone (using 280 to 400 grit stones), a glaze or a crocus cloth, depending on condition of cylinder walls.

e. Assembly. To assemble the First Stage piston and cylinder group, proceed as follows:

NOTE

A repair kit consisting of lentoid springs (12), valve ring (13), valve plate (14), spring plates (15), and cotter pin (11) is available. At overhaul replace these parts as a set. Assemble lentoid springs (12) as illustrated in Figure 6-8.

f. Assemble spring plates (15), spring tips up on both, and valve plate (14) so that fixing pin in upper plate will align these parts. Assemble valve ring (13) and lentoid springs (12) (see Figure 608).

g. Apply a very thin coating of sealing compound, per Military Specification MIL-S-46163 or equivalent, on mating outer surface between upper and lower valve plate. Apply between and around mounting holes making certain no compound will be squeezed into air port area. Assemble upper plate aligning fixing pin with holes in plates (15) and valve plate (14). Secure upper plate with nut and secure nut in position with cotter pin (11).

h. Apply a light coating of scaling colt)pound, per Military Specification MIL-S-46163, or equivalent, between and around mounting holes on top of cylinder. Make certain that no compound will be squeezed into cylinder bore area. Assemble cylinder head (5), head gasket (8), valve assembly (9), and valve gasket (16) to cylinder (17) using lock washers (7) and screws (6).

NOTE

The compression rings (3) and oil control ring (4) are available in a ring kit and are to be replaced as a set.

i. Assemble oil control ring (3) and compression rings (4) in grooves of piston (1). Coat the rings with clean compressor oil to aid in assembly.

6-18. Second Stage Cylinder and Piston Group. (See Figure 8-15). The following paragraphs contain disassembly, cleaning, inspection, repair or replacement, and assembly instructions for the second stage cylinder and piston group.

a. Disassembly. Disassemble the second stage cylinder and piston group only to the extent necessary to repair or replace a defective part or parts.

- (1) Remove the piston and pin assembly (1) with piston rings (2) from cylinder (17).

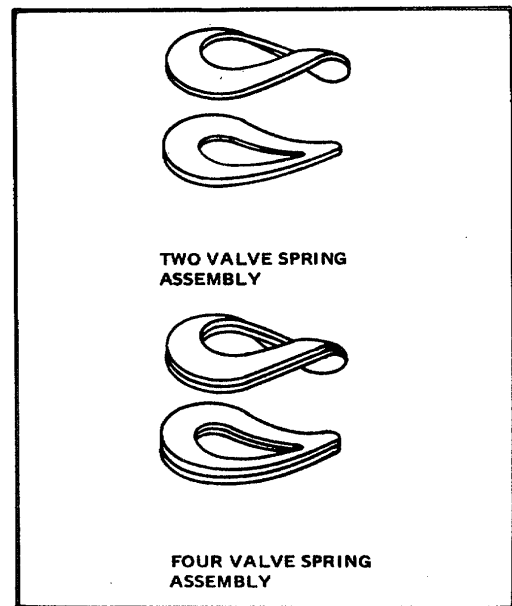

Figure 6-8. Lentoid Spring Assembly)Detail

NOTE

The piston and pin (1) are matched and are not to be replaced separately. Replace as an assembly only. The compression rings (3) and oil control ring (4) are supplied in the form of a piston ring kit and should be replaced only as a kit set.

- (2) Remove eight cap screws (6) and lock washers (7); remove cylinder head (5), head gasket (8), valve assembly (9) and valve gasket (16) from cylinder (17).
- (3) To disassemble valve assembly (9), remove cotter pin (11) and castle nut; separate upper plate from lower plate.

NOTE

The valve ring (14), lentoid springs (12), valve ring (13), lentoid springs (15), and cotter pin (11) are supplied in the form of a valve repair kit and shall be replaced as such.

- (4) Remove valve ring (14), lentoid springs (12), valve ring (13), and lentoid springs (15).
- (5) The center bolt is secured in lower plate with dowel pin peened over and neither should be removed.

b. Cleaning. Refer to paragraph 6-3.a for general cleaning instructions.

- (1) Remove caked grease or dirt with a nonmetallic brush after immersing part in solvent. Scrape carbon, grease, and old gasket material from affected surfaces.
- (2) Clean parts with care. Do not mar or scratch contact or seating surfaces. Valve components should not be wire brushed.

c. Inspection. Refer to paragraph 6-3.b for general inspection instructions.

- (1) Parts with dimensions listed in Table 6-1, Table of Limits, shall be measured to ascertain acceptability for repair or replacement and assembly.

d. Repair or Replacement. Refer to paragraph 6-3.c for general repair or replacement instructions.

- (1) Replace all gaskets removed during disassembly.



Do not remove any more material than is necessary to completely remove the glaze. Clean the cylinders in accordance with CLEANING procedures.

- (2) Remove glaze from cylinder walls with portable cylinder hone (using 280 to 400 grit stones), a glaze or a crocus cloth, depending on condition of cylinder walls.

e. Assembly. To assemble the second stage cylinder and piston group, proceed as follows:

NOTE

A repair kit consisting of valve ring (14), lentoid springs (12), valve ring (13), lentoid springs (15), and cotter pin (11) is available. At overhaul replace these parts as a set. Assemble lentoid springs (12 and 15) as shown in Figure 6-8.

- (1) At overhaul of intake-exhaust valve assembly (9, Figure 8-15) use available repair kit. Assemble lentoid springs (15), valve ring (13), lentoid springs (12), valve ring (14) and upper plate attach with nut and secure the nut in place on center bolt with cotter pin (11).
- (2) Assemble valve gasket (16), intake-exhaust valve assembly (9), head gasket (8), and cylinder head (5). Secure head with eight lock washers (7) and eight 1-1/4 inch long cap screws (6). See Table 6-2 for torque values.

6-19. Third Stage Cylinder and Piston Group. (See Figure 8-16). The following paragraphs contain disassembly, cleaning, inspection, repair or replacement, and assembly instructions for the third stage cylinder and piston group.

a. Disassembly. Disassemble the third stage cylinder and piston group only to the extent necessary to repair or replace a defective part or parts.

- (1) Remove the piston and pin assembly (1) with piston rings (2) from cylinder (16).

NOTE

The piston and pin (1) are matched and are not replaced separately. Replace as an assembly only. The three ring assemblies (2) each consisting of an outer ring and an inner ring (3) are supplied in the form of a piston ring kit and should be replaced as a kit set.

- (2) Remove four cap screws (5) and lock washers (6); remove cylinder head (4), head gasket (7), valve assembly (8) and valve gasket (15) from cylinder (16).
- (3) To disassemble valve assembly (8), remove cotter pin (10), castle nut and separate upper guard from valve seat.

NOTE

The lentoid springs (11), valve ring (12), lentoid springs (13), valve ring (14), and cotter pin (10) are supplied in the form of valve repair kit and shall be replaced as such.

- (4) Remove lentoid springs (11), valve ring (12), separate and remove lower guard, remove lentoid springs (13), and valve ring (14) from valve seat.
- (5) The center bolt is secured in valve seat with dowel pin peened over and neither should be removed.

b. Cleaning. Refer to paragraph 6-3.a for general cleaning instructions.

- (1) Remove caked grease or dirt with a non-metallic brush after immersing part in solvent. Scrape carbon, and old gasket material from affected surfaces.
- (2) Clean parts with care. Do not mar or scratch contact or seating surfaces. Exhaust valve components should not be wire brushed.

c. Inspection. Refer to paragraph 6-3.b for general inspection instructions.

- (1) Parts with dimensions listed in Table 6-1, Table of Limits, shall be measured to ascertain acceptability for repair or replacement and assembly.

d. Repair or Replacement. Refer to paragraph 6-3.c for general repair or replacement instructions.

(1) Replace all gaskets removed during disassembly.



Do not remove any more material than is necessary to completely remove the glaze. Clean the cylinders in accordance with CLEANING procedures.

- (2) Remove glaze from cylinder walls with portable cylinder hone (using 280 to 400 grit stones), a glaze buffer, or a crocus cloth, depending on condition of cylinder walls.

e. Assembly. To assemble the third stage cylinder and piston group, proceed as follows:

NOTE

A repair kit consisting of lentoid springs (11), valve ring (12), lentoid springs (13), valve ring (14), and cotter pin (10) is available. At overhaul replace these parts as a set. Assemble lentoid springs (11 and 13) as illustrated in Figure 6-8.

- (1) At overhaul of intake-exhaust valve assembly (8), use available repair kit (9). Assemble valve ring (14) and lentoid springs (13) in valve seat and assemble lower guard plate. Assemble valve ring (12), lentoid springs (11), upper guard and castle nut. Secure nut on center bolt with cotter pin (10).
- (2) Assemble valve gasket (15), valve assembly (8), head gasket (7), and cylinder head (4) to cylinder (16). Secure head to cylinder with lock washers (6) and cap screws (5). Torque cap screws (5) to 45 pounds foot (Table 6-2).

NOTE

The piston ring assemblies (2) are available in a ring kit and are to be replaced as a set.

- (3) Assemble inner and outer rings of ring assemblies (3) in grooves on piston (1). Coat the rings with clean compressor oil to aid in assembly.

6-20. Fourth Stage Head and Cylinder Group (See Figure 8-17). The following paragraphs contain disassembly, cleaning, inspection, repair or replacement, and assembly instructions for the fourth stage head and cylinder group.

a. Disassembly. Disassemble the fourth stage head and cylinder group only to the extent necessary to repair or replace a defective part or parts.

- (1) Remove eight cap screws (2), lock washers (3), remove cylinder head (1), head gasket (4), valve assembly (5), and valve gasket (11).
- (2) To disassemble valve assembly (5), separate and remove lower guard and remove lentoid springs (7) and valve ring (8). Separate and remove upper guard from valve seat and remove the closing spring (9) and valve disc (10).
- (3) Pipe plug (12) need not be removed from cylinder (15). The cylinder liner (14) is a press fit in cylinder (15). To remove, use an arbor press or other suitable means, and press liner out of cylinder in the direction of the head (toward top of cylinder).

b. Cleaning. Refer to paragraph 6-3.a for general cleaning instructions.

- (1) Remove caked grease or dirt with a non-metallic brush after immersing part in solvent. Scrape carbon, grease, and old gasket material from affected surfaces.
- (2) Clean cylinder with care. Do not mar or scratch contact or seating surfaces.

c. Inspection. Refer to paragraph 6-3.b for general inspection instructions.

- (1) Parts with dimensions listed in Table 6-1, Table of Limits, shall be measured to ascertain acceptability for repair or replacement and assembly.
- (2) All parts or subassemblies which do not meet minimum acceptable standards shall be repaired or replaced with a like serviceable item.

d. Repair or Replacement. Refer to paragraph 6-3.c for general repair or replacement instructions.

- (1) Replace all gaskets removed during disassembly.

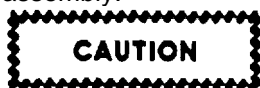

Do not remove any more material than is necessary to completely remove the glaze. Clean the cylinders in accordance with CLEANING

procedures.

- (2) Remove glaze from cylinder walls with portable cylinder hone (using 280 to 400 grit stones), a glaze breaker, or crocus cloth, depending on condition of cylinder walls.

e. Assembly. To assemble the fourth stage cylinder group, proceed as follows:



When cylinder liner (14) is pressed into cylinder (15), make certain that oil hole in skirt of liner (14) is aligned with oil hole in cylinder (15). Assemble cylinder to crankcase with the oil inlet hole on top side.

- (1) If cylinder liner (14) was disassembled from cylinder (15), press into position aligning oil hole in liner skirt with oil hole in cylinder. Assemble pipe plug (12) if removed at disassembly

NOTE

A repair kit consisting of lentoid springs (7), valve ring (8), closing spring (9), and valve disc (10) is available. At overhaul these parts shall be replaced as a set. Assemble lentoid springs (7) as illustrated on Figure 6-8.

(2) At overhaul of intake-exhaust valve assembly (5) use available repair kit. Assemble valve disc (10), closing spring (9), and assemble the upper guard onto seat. Install valve ring (8) and four lentoid springs (7) (see Figure 6-8) and assemble lower guard into seat.

- (3) Assemble valve gasket (11), intake-exhaust valve assembly (5), head gasket (4), cylinder head (1) and secure with lock washers (3) and cap screws (2). Torque cap screws (2) to 45 pounds foot (Table 6-1).

6-21. Fourth Stage Piston and Pin Assembly (See Figure 8-18). The following paragraphs contain disassembly, cleaning, inspection, repair or replacement, and assembly instructions for the fourth stage piston assembly.

a. Disassembly. Disassemble the fourth stage piston assembly only to the extent necessary to repair or replace a defective part or parts.

- (1) Unscrew and remove stem nut (1), remove ring kit
- (2) Note ring kit component assembly order. The piston and pin are matched and shall be kept together as an assembly (7). The piston or pin are not available separately.

b. Cleaning. Refer to paragraph 6-3.a for general cleaning instructions.

- (1) Clean piston with care. Do not mar or scratch contact or seating surfaces. Piston ring grooves must be cleaned with care so as not to scratch or mar grooved surfaces. Use a ring groove cleaner corresponding to groove size for this purpose.

c. Inspection. Refer to paragraph 6-3.b for general inspection instructions.. Refer to Table 6-1 for dimensional inspection.

d. Repair or Replacement. Refer to paragraph 6-3.c for general repair or replacement instructions.

(1) Replace all damaged parts, and parts that do not meet dimensional requirements of Table 6-1, Table of Limits.

- (2) Replace rings and spacers as a kit (2, Figure 8-18).

e. Assembly. To assemble the fourth stage piston and pin assembly, proceed as follows.

- (1) Assemble ring kit (2) components onto piston bolt (7) in the order as shown (2, Figure 8-18).
- (2) Apply 3 to 4 drops Loc-Tite No. 290 (green) or equivalent to stem threads and install stem nut (1). Tighten nut (1) to 9 foot-pounds torque.

6-22. Clutch and Clutch Housing Group (See Figure 8-19). The following paragraphs contain disassembly, cleaning, inspection, repair or replacement, and assembly instructions for the clutch and clutch housing group.

a. Disassembly. Disassemble the clutch and clutch housing group only to the extent necessary to repair or replace a defective part or parts.

- (1) If not already removed, remove cotter pin (2), clevis pin (3) from yoke (4); separate rod yoke (4) from shaft assembly (12). Loosen nut (5), unscrew and remove rod yoke (4) and nut (5) from clutch rod (1).

- (2) Remove screws (7), lock washers (8) and remove cover (6). Loosen cap screws securing throwout yoke (14) to shaft assembly (12), slowly withdraw shaft assembly (12) from clutch housing (15) and remove throwout yoke (14) and yoke keys (13).

- (3) Unscrew and remove fitting (9), coupling (10), and nipple (11) from clutch assembly (28).

- (4) Remove four cap screws (17) and lock washer (18). Carefully remove clutch housing assembly (15) from engine.

- (5) Do not remove bushing (16) from housing (15) unless replacement is required.

- (6) Remove cap screw (25), lock washer (26), and drive washer assembly (22) from engine crankshaft. Do not disassemble the drive washer (22) unless replacement of pin (23) or washer (24) is necessary.

- (7) Using a gear puller, or equivalent, break clutch assembly loose from engine crankshaft. Slide clutch assembly (28) back on crankshaft until woodruff key (27) is exposed. Using a pair of needle nose pliers, or equivalent, remove key (27) from recess in crankshaft. Remove clutch assembly from engine crankshaft.

- (8) Remove nuts (30), cap screws (31), spacer (32) and clutch collar (33).

- (9) Remove cotter pins (34), pins (35), washer weights (36) and links (37). Push out and remove pin (38).

- (10) Remove cotter pin (40), pin (41) and links (42). Push upward on locking pin (46) against the spring (47), slip small diameter wire through hole in locking pin (46) to hold pin in place. Grasp the sliding sleeve (39) and the hub (53) and unscrew counter clockwise.

- (11) Remove drive plates (50), floating plate (49) from hub (53). Remove release springs (51) from hub (53). Plate pin (52) does not need to be removed, and should be removed only as necessary.

b. Cleaning. Refer to paragraph 6-3.a for general cleaning instructions.

c. Inspection. Refer to paragraph 6-3.b for general inspection instructions.

- (1) Inspect drive plates (50) for warpage, broken or missing teeth.

d. Repair or Replacement. Refer to paragraph 6-3.c for general repair or replacement instructions.

- (1) Replace damaged or defective driving plate (50) segments.

e. Assembly. To assemble the clutch and clutch housing group, proceed as follows: (1) Install release springs (51) in hub (53). Place drive plates (50) in position and install floating plate (49) on hub (53). Screw the sliding sleeve (39) to hub (53). Remove wire pin from locking pin (46). Insure locking pin (46) snaps into place.

- (2) Attach links (42), pins (41), and cotter pins (40).
- (3) Install pin (38), links (37), washer weights (36) and cotter pins (34).
- (4) Position clutch collar (33) on sleeve (39), insert spacers (32) and attach using screws (31) and nuts (30).



Do not over torque screw (25).

- (5) Position clutch assembly (28) on shaft and insert key (27). Assemble clevis washer (22) to engine drive shaft using lock washer (26) and screw (25). Use Loc-Tite No. 277 (red), torque screw (25) to 20 ft-lbs.
- (6) Carefully position clutch housing (15) over clutch assembly (28), attach housing (15) to engine block with lock washers (18) and screws (17). Assemble nipple (11), coupling (10), and fitting (9), screw fitting (9) into clutch assembly (28).
- (7) Position yoke (14) in clutch housing; insert shaft assembly (12) through bushing (16), assemble yoke key (13) to shaft (12) carefully insert shaft (12) into yoke (14). Tighten cap screws on yoke (14) when shaft with keys (13) is properly positioned in yoke (14).
- (8) Assemble cover (6) to housing (15) using

lock washers (8) and screws (7). Assemble nut (5) and rod yoke (4) to clutch rod (1). Position rod yoke (4) over shaft (12) and insert pin (3) and cotter pin (2).

6. . Trap Group (See Figure 8-20). The following paragraphs contain disassembly, cleaning, inspection, repair or replacement, and assembly instructions for the trap group.

a. Disassembly. Disassemble the trap group only to the extent necessary to repair or replace a defective part or parts.

- (1) Disconnect and remove second stage trap tube assemblies (1, 3, and 4) and hose assembly (2). Identify hose assembly for reassembly reference.
- (2) Disconnect and remove first stage trap hose assemblies (6, 7 and 8) and tube assembly (9). Identify hose and tube assembly for reassembly reference.
- (3) Disconnect and remove third stage trap hose assemblies (5 and 10) and tube assembly (11). Identify hose assembly for reassembly reference.
- (4) Disconnect and remove receiver accumulator hose assemblies (6, 12, and 13). Identify tube assembly for reassembly reference.
- (5) Remove screws (14) and lock washers (15) from trap assemblies (16, 17 and 18). Remove traps from mounting bracket (23).
- (6) Remove screws (14) and lock washers (15) from accumulator assembly (19). Remove from mounting bracket (23).
- (7) Remove nuts (20), lock washers (21) and screws (22) from mounting bracket (23), and remove bracket.

b. Cleaning. Refer to paragraph 6-3.a for general cleaning instructions.

c. Inspection. Refer to paragraph 6-3.b for general inspection instructions.

- (1) mounting bracket for straightness.

d. Repair or Replacement. Refer to paragraph 6-3.c figure general repair or replacement instructions.

- (1) mounting bracket if bent.

c. Assembly. To assemble tile trap group, proceed as follows: (1) Attach mounting bracket (23) to frame using screws (22), lock washers (21) and nuts (20).

- (2) Using lock washers (15) and screws (14), attach the accumulator assembly (19) and first, second and third stage traps (16, 17 and 18) to the mounting bracket (23).
- (3) Connect hose assemblies (13, 12 and 6) to the accumulator assembly (19).
- (4) Connect hose assemblies (5 and 10) and tube assembly (11) to the third stage trap assembly (18).
- (5) Connect hose assemblies (6, 7 and 8) and tube assembly (9) to the first stage trap assembly (17).
- (6) Connect hose assembly (2) and tube assemblies (1, 3 and 4) to the second stage trap (16) assembly.

6-24. First Stage Trap Assembly (See Figure 8-21). The following paragraphs cleaning disassembly, cleaning, inspection, repair and replacement and assembly instructions for the first stage trap assembly.

a. Disassembly. Disassemble the first stage trap assembly only to the extent necessary to repair or replace a defective part or parts.

- (1) Remove tubing adaptor (1) and tubing elbow (2).
- (2) Remove tubing adaptor (3) and reducing nipple (4).
- (3) Unscrew and remove the trap filter assembly (5) and o-ring packing (6) from trap body (7).

b. Cleaning. Refer to paragraph 6-3.a for general cleaning instructions.



take care not to damage line mesh filter screen.

NOTE

Do not allow parts to remain in dry cleaning solvent for extended periods of time or luster spots may form.

- (1) Thoroughly wash filter screen in solvent. per Federal Specification (D4)80, Type II. Allow filters to air dry.

NOTE

For best results, use ultrasonic cleaner, NSN 4940-00-164-8977, (Table 2-1), to clean filter screen.

- (2) Wipe out cavity of trap bodies with a lint free cloth dampened in solvent, per Federal Specification P-D-680, Type II. Allow bodies to air dry.

c. Inspection. Refer to paragraph 6-3.b for general inspection instructions.

- (1) Check the filter screen for damage such as breaks and plugging due to corrosion.
- (2) Check o-ring for deterioration, cuts, or other damage.

d. Repair or Replacement. Refer to paragraph 6-3.c for general repair or replacement instructions.



Do not allow solder to foul filter screw threads.

- (1) If screen is undamaged and screen-to-screw solder joint is broken, use a gas torch to silver solder screen to screw. Use rosin residue remover to remove solder flux residue, oil, and grease from trap filter.
- (2) if filter screen is damaged, replace the trap filter subassembly.
- (3) Replace all threaded parts having worn, stripped, or damaged threads.
- (4) Replace damaged or defective fittings.

c. Assembly. To assemble the first stage trap assembly, proceed as follows:

- (1) Attach new o-ring (6), on filter assembly (5). Install filter assembly (5) into trap body (7).
- (2) Install reducing nipple (4), tubing adaptor (3), tubing elbow (2) and adaptor (1).

6-25. Second Stage Trap Assembly (See Figure 8-22). The following paragraphs contain disassembly, cleaning, inspection, repair and replacement and assembly instructions for the second stage trap assembly.

a. Disassembly. Disassemble the second stage trap assembly only to the extent necessary to repair or replace a defective part or parts.

(1) Remove two tubing adaptors (1 and 2), pipe tee (3), nipple (4), and reducing bushing (5), from trap body (16).

(2) Remove tubing elbow (6), check valve (7), close nipple (8), reducer (9), elbow (10), street tee (11), reducer (12) and adapter (13) from trap body (16).

(3) Unscrew and remove trap filter assembly (14) and o-ring packing (15) from trap body (16).

b. Cleaning. Refer to paragraph 6-3.a for general cleaning instructions.



Take care not to damage the fine mesh filter screen.

NOTE

Do not allow parts to remain in dry cleaning solvents for extended periods of time or rust spots may form.

- (1) Thoroughly wash filter screen in solvent, per Federal Specification P-D-680, Type II. Allow filters to air dry.

NOTE

For best results, use ultrasonic cleaner, NSN 4940-00-164-8977, (Table 2-1), to clean filter screen.

- (2) Wipe out cavity of trap bodies with a lint-free cloth dampened in solvent, per Federal Specification P-D-680, Type II. Allow bodies to air dry.

c. Inspection. Refer to paragraph 6-3.b for general inspection instructions.

- (1) Check the filter screen for damage such as breaks and plugging due to corrosion.
- (2) Check o-ring for deterioration, cuts, or other damage.

d. Repair or Replacement. Refer to paragraph 6-3.c for general repair or replacement instructions.



Do not allow solder to foul filter screw threads.

- (1) If screen is undamaged and screen-to-screw solder joint is broken, use a gas torch to silver solder screen to screw. Use rosin residue remover to remove solder flux residue oil, and residue from trap filter.
- (2) If filter screen is damaged, replace the trap filter subassembly.
- (3) Replace damaged or defective fittings.
- (4) Replace a damaged or defective check valve.

e. Assembly. To assemble the second stage trap assembly, proceed as follows: (1) Assemble o-ring (15) and trap filter (14) in top of trap body (16). Install adaptor (13) in body (16).

- (2) Install reducing bushing (12) in body (16), assemble street tee (11) on bushing (12).
- (3) Assemble elbow (10) to run on tee (11). Assemble valve (7) to nipple (8), to reducing bushing (9), and install bushing (9) in branch of pipe tee (11). Assemble elbow (6) to valve (7).
- (4) Install reducing bushing (5) in body, assemble hex nipple (4) to pipe tee (3), and install nipple (4) in bushing (5). Assemble adaptors (1 and 2) to pipe tee (3).

6-26. Third Stage Trap Assembly (See Figure 8-23). The following paragraphs contain disassembly, cleaning,

inspection, repair and replacement, and assembly instructions for the third stage trap assembly.

a. Disassembly. Disassemble the third stage trap assembly only to the extent necessary to repair or replace a defective part or parts.

- (1) Remove tubing elbow (1), tubing elbow (2), tubing adaptor (3) and bleed valve assembly (4) from strainer (9).

NOTE

Refer to BLEED VALVE SUBASSEMBLY (Section VI) for bleed valve repair instructions.

- (2) Remove reducing nipple (5) and line strainer (6) from trap body (12).
- (3) To disassemble strainer assembly (6), remove plug and screen assembly (7) and o-ring packing (8) from strainer body (9).
- (4) Unscrew and remove trap filter assembly (10) and o-ring packing (11) from trap body (12).

b. Cleaning. Refer to paragraph 6-3.a for general cleaning instructions.



Take care not to damage the fine mesh filter screen.

NOTE

Do not allow parts to remain in dry cleaning solvent for extended periods of time or rust spots may form.

- (1) Thoroughly wash filter screen in solvent, per Federal Specification P-D-680, Type II1. Allow filters to air dry.

NOTE

For best results, use ultrasonic cleaner, USN 4940-00-164-8977. (Table 2-1). to clean the strainer filter screen.

- (2) Wipe out cavity of trap bodies with a line-free cloth dampened in solvent, per Federal Specification 1P-I)600. Type II. Allow bodies to air dry.

c. Inspection. Refer to paragraph 6-3.b for general inspection instructions.

- (1) Check the filter screen for damage such as breaks and plugging due to corrosion.
- (2) Check o-ring for deterioration, cuts, or other damage.

d. Repair or Replacement. Refer to paragraph 6-3.c for general repair or replacement instructions.



Do not allow solder to foul filter screw threads.

- (1) If screen is undamaged and screen-to-screw solder joint is broken, use a gas torch to silver solder screen to screw. Use rosin residue remover to remove solder flux residue oil, and grease from trap filter.
- (2) If filter screen is damaged, replace the trap filter subassembly.
- (3) Replace all threaded parts having worn, stripped, or damaged threads.
- (4) Replace damaged or defective fittings.
- (5) Replace a damaged or defective strainer.
- (6) Replace a damaged or defective continuous bleed valve.
- (7) Replace all parts that are worn or damaged to an extent that will impair their normal function.

e. Assembly. To assemble the third stage trap assembly, proceed as follows:

- (1) Assemble o-ring (11) and trap filter assembly 4(10) in top of trap body (12). Assemble o-ring (8) and the plug and screen assembly (7) into strainer body (9).
- (2) Install the reducer nipples (5) in strainer body (9).
- (3) Assemble the continuous bleed valve assembly (4) on reducing nipple (5) and install tubing adaptor (3) in bleed valve outlet.

- (4) Assemble nipple (5), strainer (9), and valve (4) to body (12).
- (5) Install elbow (2) and elbow (1) in body (12).

6-27. Accumulator Assembly (See Figure 8-24). The following paragraphs contain disassembly, cleaning, inspection, repair or replacement, and assembly instructions for the accumulator assembly.

a. Disassembly. Disassemble the accumulator assembly only to the extent necessary to repair or replace a defective part or parts.

- (1) Remove elbow (1), connector (2), tubing adaptor (3) and bleed valve (4).

NOTE

Refer to bleed valve subassembly (Section VI) for bleed valve repair instructions (see Figure 8-26).

- (2) Remove nipple (5), strainer (6), and connector (7) from accumulator body (10).

NOTE

For detailed breakdown on line strainer (6) see Figure 8-25.

- (3) See Figure 8-25. Remove plug (5) and o-ring (6) from strainer body (9). Remove seal washer (7) and strainer element (8) from the strainer body (9).
- (4) Remove cap (8) and o-ring (9) from accumulator body (10).

b. Cleaning. Refer to paragraph 6-3.a for general cleaning instructions.

- (1) Wipe out cavity of accumulator body with lint-free cloth dampened in solvent, per Federal Specification P-D-680, Type II. Allow to air dry.

NOTE

For best results, use Ultrasonic Cleaner, NSN 4)40-00-164-8977, (Table 2-1), to clean strainer filter.

- (2) Wash line strainer filter element in solvent, per 6-34 Federal Specification P-D-680, Type II1. Allow filter element to air dry.

c. Inspection. Refer to paragraph 6-3.b for general inspection instructions.

- (1) Replace a damaged strainer element.

d. Repair or Replacement. Refer to paragraph 6-3.c for general repair or replacement instructions.

- (1) Replace all parts damaged to the point of impairing these normal functions.

e. Assembly. To assemble the accumulator assembly, proceed as follows: (1) Install o-ring (9) and cap (8) into accumulator body (10).

- (2) See "A" Figure 8-25, insert strainer element (6) and seal washer (5) into strainer body (7); attach o-ring (4) to plug (3) and attach plug (3) to strainer body (7).
- (3) Install connector (7, Figure 8-24), strainer (6) and nipple (5) to accumulator body (10).
- (4) Attach adaptor (3) to bleed valve (4), install bleed valve (4) on nipple (5). Install connector (2) and elbow (1) to accumulator body (10).

6-28. Bleed Valve Assembly (See Figure 8-25). The following paragraphs contain disassembly, cleaning, inspection, repair or replacement and assembly instructions for the bleed valve assembly.

a. Disassembly. Disassemble the bleed valve assembly only to the extent necessary to repair or replace a defective part or parts.

NOTE

Note position of elbows (1) prior to removal.

- (1) Remove elbows (1) and strainers (2).
- (2) Unscrew body plug (3) from strainer body (7), remove o-ring (4) from plug (3).
- (3) Remove seal washer (5) and strainer element (6) from strainer body (7).

- (4) Remove reducer nipple (8) and adaptors (9). Loosen and remove bleed valve (10), mounting screws and remove bleed valves (10) from mounting bracket (I I).

NOTE

Replace lock washers and screws in bleed valve body

- b. Cleaning. Refer to paragraph 6-3.a for general cleaning instructions.

- (1) Wipe non-metallic parts with a clean lint-free cloth moistened in detergent and water and air dry.

NOTE

For best results, use ultrasonic cleaner, NSN 4940-00-164-8977, (Table ' -1), to clean strainer filters.

- (2) Wash line strainer filter elements in solvent, per Federal Specification P-D-680, Type II. Allow elements to air dry.

- c. Inspection. Refer to paragraph 6-3.b for general inspection instructions.

- (1) Element damage.

- d. Repair or Replacement. Refer to paragraph 6-3.c for general repair or replacement instructions.

- (1) Replace damaged strainer element.
 - (2) Straighten bent mounting bracket.

- e. Assembly. To assemble the bleed valve assembly, proceed as follows: (1) Install adaptors (9) and reducer nipples (8) in bleed valves (10).

- (2) Insert element (6), seal washer (5) in strainer body (7). Place o-ring (4) o011 plug (3) and install plug (3) into strainer body (7). Install strainers (2) into nipples (8).
 - (3) Install elbows (1) in strainer (2). Position elbow (1) as shown in Figure 8-25.
 - (4) Unscrew mounting screws from bleed valve body (10) and attach valve (10) to mounting bracket (I I) using lock washers and bleed valve screws.

6-29. Continuous Bleed Valve Subassembly (See Figure 8-26). The following paragraphs contain disassembly, cleaning inspection, repair or replacement and assembly instructions for the continuous bleed valve subassembly.

- a. Disassembly. Disassemble the continuous bleed valve subassembly only to the extent necessary to repair or replace a defective part or parts.

- (1) Remove six screws (2) and lock washers (3) attaching valve cap to valve body (12).



Mark or tag the third stage continuous bleed valve spring at disassembly as it differs from the first and second stage bleed valve springs.

- (2) Remove spring (4), unscrew locknut (5); separate diaphragm plate (6), diaphragm (7), and orifice screw (8).
 - (3) Remove valve plunger (9) from valve seat (10) and bleed valve (11) from body (12).

- b. Cleaning. Refer to paragraph 6-3.a for general cleaning instructions.

- (1) Wash all parts, except diaphragm (7), thoroughly with solvent, P-D-680, or equivalent.
 - (2) Make certain that air passages in orifice screw (8), valve plunger (9), and valve seat (10) are clean and free of any obstruction.
 - (3) Wipe the diaphragm (7) with a clean, lint-free cloth moistened with solvent.
 - (4) Air dry cleaned parts.

- c. Inspection. Refer to paragraph 6-3.b for general inspection instructions.

- (1) Parts with dimensions listed in Table 6-1, Table of Limits, shall be measured to determine acceptability for repair and assembly.
 - (2) Diaphragm (7) for cuts, tears, separation, and any other defect.

- (3) Valve seat (10) and bleed valve (11) for nicks and burrs that will cause sticking or clogging of orifices.
- (4) Spring (4) for breaks and set. Refer to Table 6-1.

NOTE

Third stage spring (4) differs from the first, second and accumulator bleed valve springs (4). Keep separated.

d. Repair or Replacement. Refer to paragraph 6-3.c for general repair or replacement instructions.

- (1) Replace a damaged diaphragm.
- (2) Replace a defective spring.

e. Assembly. To assemble the continuous bleed valve subassembly, proceed as follows:

NOTE

Repair kits consisting of spring (4), diaphragm plate (6), diaphragm (7), orifice screw (8), valve plunger (9), valve seat (10), and bleed valve (11) are available for each of the two bleed valve subassemblies. The kits differ only in springs (4). Care shall be taken so as not to assemble the wrong spring. At overhaul of the bleed valve subassemblies, these kits shall be used.

- (1) Assemble orifice screw (8), diaphragm (7), diaphragm plate (6), and secure together with locknut (5).
- (2) Install bleed valve (11) in bore of valve seat (10) with tapered end of valve (11) into bore first. Screw valve seat (10) into body until head of seat bottoms in body. Tighten securely.
- (3) Place valve plunger (9) in center hole of valve seat head (10) making certain small end of plunger (9) enters the small air passage hole in seat (10).
- (4) Position diaphragm (7) aligning diaphragm holes with tapped holes in body (12).



When assembling spring (4), make certain that proper spring is assembled for the third stage application. The third stage spring has free length of 2-3/4 inches, whereas, first and second stage spring free length is 2 inches. Assemble the third stage spring in the assembly that has a 3 stamped into the face of body (12).

- (5) Assemble proper spring (4) on diaphragm plate (6). Assemble cap (1) to body (12), aligning holes so that correct inlet to outlet relationship is obtained. (See Figure 6-9). Attach cap to body with lock washers (3) and cap screws (2). Tighten cap screws (2) to 16 + 1 pound-inch (1.81 + 0.113 Nm) of torque.

6-30. Drain Valve Assembly (See Figure 8-27). The following paragraphs contain disassembly, cleaning, inspection, repair or replacement and assembly instructions for the drain valve assembly.

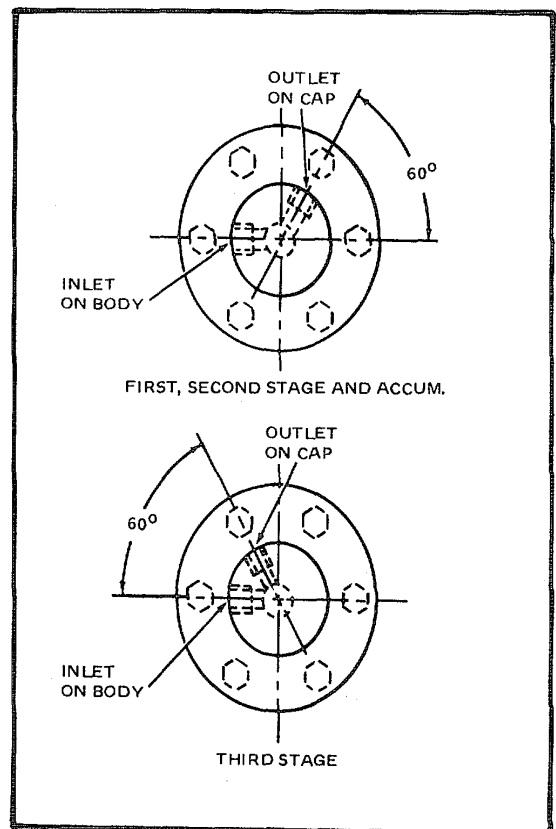

Figure 6-9. Bleed Valve Port Locations

a. Disassembly. Disassemble the drain valve assembly only to the extent necessary to repair or replace a defective parts or parts.

- (1) Remove two screws (5) attaching drain valve (7) to mounting bracket (6). Unscrew and remove tubing tee (1) from drain' valve (7).
- (2) Remove tubing tee (2), tubing adaptor (4),and pipe plugs (3). Unscrew and remove three cap screws (9), lock washers (10), and separate cap (8) front body (20). Remove spring (11).
- (3) Place a 1/8 inch diameter rod through hole in side of body (20) and through hole in valve stein to keep stem from turning and remove locknut (13); then, remove rod. Remove piston (12) and o-ring (14).
- (4) Unscrew and remove valve body screw (15), tap on end of stem (17) to remove seat (16) and valve stem (17). Remove o-ring (18) and backup ring (19) from stem (17).

b. Cleaning. Refer to paragraph 6-3.a for general cleanm1, instructions.

c. Inspection. Refer to paragraph 6-3.b for general inspection instructions.

- (1) Parts with dimensions listed in Table 6-1, Table of Limits, shall be measured to determine acceptability for repair and assembly.
- (2) Inspect valve spring for cracks. breaks, and set. Refer to Table 6-2.
- (3) Inspect drain valve piston for nicks and burrs that could cause sticking.
- (4) Inspect valve seat for nicks, burrs, or clogged passages.

d. Repair or Replacement. Refer to paragraph 6-3.c for general repair or replacement instructions.

- (1) Replace all parts that are worn or damaged to an extent that will impair their normal function.

e. Assembly. To assemble the drain valve assembly, proceed as follows: (l) Assemble o-ring (18), and backup ring ()19) on valve stem (17). Lubricate o-ring with very light coating of clean compressor oil to aid assembly.

- (2) Assemble stem (17) into valve body (20) and place a 1/8 inch diameter rod through hole in side of body and hole in stem to keep stem from turning when tightening locknut (13). Assemble o-ring (14) on piston (12), assemble piston in bore of body over end of stem and secure with locknut (13). Remove the 1/8 inch rod.
- (3) Assemble seat (16) and body screw (15) in body (20). Attach mounting bracket (6) to bottom of body (20) with screws (5), positioned with mounting extension facing side opposite tubing tee (2).
- (4) Assemble spring (11) and cap (8). Secure cap to body with lock washers (10) and cap screws (9).
- (5) Install pipe plugs (3), tubing adaptor (4), and tubing tee (2). Position tubing tee (2) with run of tee horizontal with respect to mounting bracket.
- (6) Use a wrench to hold body screw (5) and install tubing tee (1) into body screw with run of tubing tee (1) parallel with the run of tubing tee (2).
- (7) Attach mounting plate (6) to compressor frame using mounting nuts, flat washers and mounting screws.

6-31. Unloader Control Box Group (See Figure 8-28). The following paragraphs contain disassembly, cleaning, inspection, repair or replacement, and assembly instructions for the unloader control box group.

a. Disassembly. Disassemble the unloader control box group only -to the extent necessary to repair or replace a defective part or parts.

- (1) Remove nuts (7), lock washers (8), flat washers (9), five insulator washers (10), and machine screws (11). Remove plug (12).
- (2) Remove nuts (1) and washers (2) from control box mounts (3). Replace washers and nuts after box is removed.

- (3) Remove nuts (4) and washers (2).
Remove shock mounts from frame (5).
- (4) Remove adaptor (13) from pressure switch (14). Unscrew and remove mounting nut and washer securing pressure switch to box and remove pressure switch (14). When damaged only, remove the two lug terminals (15) from pressure switch leads.
- (5) Remove tubing elbow (16) and connector (17) from solenoid valve (19) only when replacement is required, or repair to solenoid (19) is required. Remove the corner screw holding box inner panel and ground leads from solenoid valve (19) and safety relay (22). Remove diode subassembly (21) from box. Unscrew and remove connector (18) and withdraw solenoid valve (19) from mounting hole.
- (6) Only when necessary, remove terminal lugs (20) from solenoid switch (19) leads.
- (7) Remove the remaining three screws attaching box inner panel in place. Lift the panel from the box and remove nut (26), lock washer (27), and screw (28) which attach the safety relay (29) to the box panel. Only when damaged, unsolder and remove wire assemblies (22, 20 and 25) and wire lead (23) from control relay (29).
- (8) To avoid losing parts until ready to assemble, attach lower inner panel in place in the control box assembly (30) with the four corner screws removed during disassembly.

b. Cleaning. Refer to paragraph 6-3.a for general cleaning instructions.

- (1) Clean components with trichloroethane, per Federal Specification O-T-620, or equivalent.
- (2) Allow parts to dry thoroughly before attempting to operate the equipment.

c. Inspection. Refer to paragraph 6-3.b for general inspection instructions.

- (1) Test solenoid valve as follows: (a) Using a multimeter, check for continuity across coil of the solenoid valve. Meter should indicate zero (0) ohms.

(b) Connect solenoid valve coil leads across the

terminals of a 12 volt DC power source. A metallic click indicates the solenoid valve is operating properly.

(2) Test pressure switch as follows:

(a) Install pressure switch to be tested in test setup shown in Figure 6-10 or equivalent.

NOTE

The test setup shall incorporate a master pressure gauge of known accuracy together with suitable pressure regulating and controlling apparatus. The C lead is common, NO lead is normally open, and the NC lead is normally closed.

(b) Adjust pressure source until pressure gauge indicates 3,300 psig (22,754 KPa).

(c) Slowly increase pressure until lamp A lights. Lamp B shall light between 3,250 (22,392 KPa) and 3,350 psig (23,081 KPa).

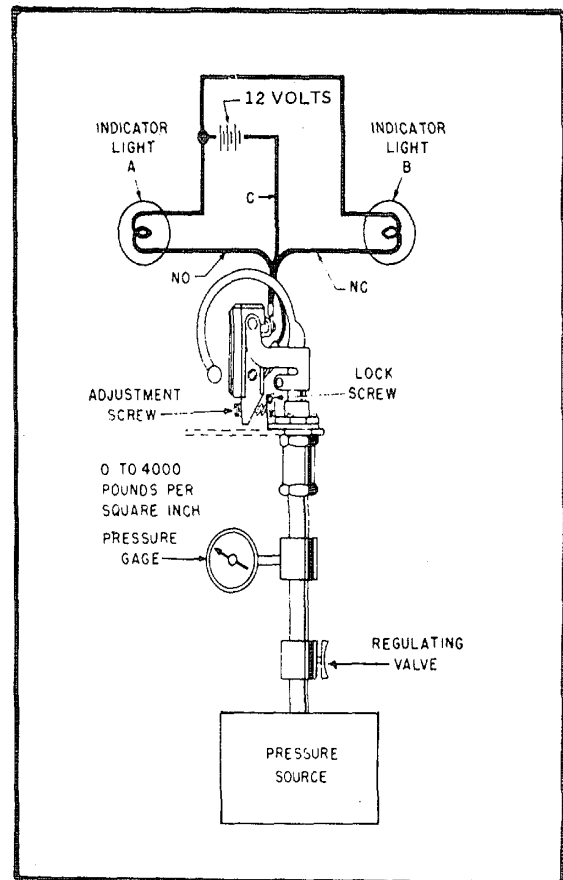

Figure 6-10. Pressure Switch Test Setup

NOTE

This occurs when actuation point of switch is adjusted for 3, 200 psig (22, 348 KPa).

- (d) Slowly increase pressure above 3, 350 psig. Indicator A should light.
- (e) If lamp does light within the specified limits, adjust actuation point of pressure switch by loosening lock screw and turning adjustment screw clockwise to lower actuation point or counterclockwise to raise it.
- (f) Repeat steps b through e until indicators light within the specified limits.
- (g) If correct indication cannot be obtained, switch is defective.

d. Repair or Replacement. Refer to paragraph 6-3.c for general repair or replacement instructions.

- (1) Replace defective wiring.
- (2) Replace defective solenoid valve.
- (3) Replace defective pressure switch.

e. Assembly. To assemble the unloader control box group, proceed as follows:

- (1) Disconnect and separate inner panel from control box (30).
- (2) Using screws (28), lockwasher (27) and nuts (6) attach relay (39) to inner panel. Position the inner panel in the control box (30).
- (3) Thread wiring (20) through connector nut (18) and insert solenoid (19) wiring through hole in the side of control box (30). Thread wiring through lock washer and connector; attach solenoid (19) to control box (30). If removed, install connector (17) and elbow (16) on solenoid (19).
- (4) Connect solenoid ground wire (20) and diode assembly (21) to inner panel using attaching screw.
- (5) Insert pressure switch (14) through hole in front of control box (30), and attach switch to control box using washer and nut (14). Screw

adaptor (13) into pressure switch (14). Snap in plug (12).

- (6) Using screw (11) attach terminal (22), washer (9), and insulated washer (10); insert through hole No. 1 in control box. Attach washer (10), washers (9) lock washer (8) and nut (7) to screw (11).
- (7) Using screw (11) attach terminal (25), washer (9) and insulated washer (10); insert screw (1) through hole No. 2 in control box. Attach washer (10), washers (9), lock washer (8) and nuts (7) to screw (11).
- (8) Using screw (11) attach terminal (24), washer (9), insulated washer (10); insert screw (11) through hole No. 3 in control box. Attach washer (10), washers (9), lock washer (8) and nuts (7) to screw (11).
- (9) Using screw (1) attach terminals (15), washer (9), and insulated washer (10); insert screw (11) through hole No. 4 in control box. Attach washer (10), washers (9), lock washer (8) and nuts (7) to screw (11).
- (10) Using screw (11) attach terminals (15, 20, and 21), washer (9), insulated washer (10), insert screw (11) through hole No. 5 in control box. Attach washer (10), washer (9), lock washer (8) and nuts (7) to screw (11).
- (11) Attach shock mounts (3) to mounting brackets (5) using lock washer (2) and nut (4).
- (12) Attach unloader control assembly (7) to shock mounts (3) using lock washer (2) and nuts (1).

6-32. Condensate Receiver Group (See Figure 8.29). The following paragraphs contain disassembly, cleaning, inspection, repair or replacement, and assembly instructions for the condensate receiver group.

a. Disassembly. Disassemble the condensate receiver group only to the extent necessary to repair or replace a defective part or parts.

- (1) Disconnect and remove drain hose (1) and tube assembly (5). Identify for reassembly purposes.
- (2) Unscrew and remove screws (10) lock washer (11), remove separator cap (12) and gasket (13). Remove elbow (14).

- (3) Remove mounting nuts (8) and remove receiver box (23) from mounting brackets (9).
- (4) Remove nipple (17) from receiver box (23); un-screw and remove elbow (16) from nipple (17), and valve (15) from elbow (16).
- (5) Remove nut (19), hose connector (20), flat washer (21) and rubber grommet (22) from receiver box (23).

b. Cleaning. Refer to paragraph 6-3 for general cleaning instructions.

c. Inspection. Refer to paragraph 6-3 for general in-spection instructions.

(1) Check rubber parts for cracks, deterioration or tears.

(2) Check condensate receiver box for dents or cracks.

d. Repair or Replacement. Refer to paragraph 6-3 for general repair or replacement instructions.

(1) Replace gaskets or o-rings removed during dis-assembly.

(2) Straighten dents and repair cracks, replace if damage is too severe.

e. Assembly. To assemble the condensate receiver group, proceed as follows:

(1) Insert rubber grommet (22) in receiver box (23), place flat washer (21) over hose connector (20) and insert into box (23). Attach to box using nut (19).

(2) Attach valve (15) to elbow (16), and elbow (16) to nipple (17). Attach nipple (17) to bottom of receiver box (23).

(3) Mount receiver box (23) and secure with nuts (8) to mounts (9).

(4) Place gasket (13) and separator cap (12) on receiver box (23), secure with lock washers (11) and screws (10). Assemble elbow (14) to separator cap (12).

(5) Attach tube assembly (5) to elbow (14), and insert hose (1) onto hose connector (20).

6-33. Diesel Engine Assembly (See Figure 8-30). The following paragraphs contain disassembly, cleaning, inspection, repair or replacement, and assembly instructions for the diesel engine assembly.

- a. Disassembly. Disassemble the diesel engine assembly only to the extent necessary to repair or replace a defective part or parts.

WARNING

Do not bend engine lifting straps past the vertical plane, or failure of the straps could occur.

NOTE

Disconnect engine electrical wiring as needed during disassembly process. Tag for reassembly purposes.

NOTE

Disassembly and assembly of the diesel engine will require the use of metric tools.

(1) Drain oil (14, Figure 8-30, Sheet 1 of 10) and unscrew and remove oil filter (19). Disconnect oil drain hose assembly (14) from frame prior to engine removal.

(2) Disconnect fuel bleed off line at fuel tank filler.

(3) If not previously disconnected, remove clips (1a, 1b) and attaching hardware (Figure 8-30, Sheet 1 of 10), loosen screw in wire stop (13) and pull throttle cable (11) loose from the engine. Reattach clips and hardware.

(4) Disconnect oil pressure hose at oil pressure switch (20).

(5) Remove engine mounting nuts and flat washers (17, Figure 8-30, Sheet 1 of 10). Use suitable hoist or lifting device and remove engine from frame. Replace washers and nuts on shock mounts.

(6) Unscrew and remove screws (3, Figure 8-30, Sheet 2 of 10) and lock washers (4) from air intake manifold (11). Remove support strap (2) and remove air breather (5) with rain cap

- (1) from manifold (11). Remove gasket (6) and support plate (7) from manifold (11).
- (7) Remove nuts (13) from manifold studs; remove manifold (11) and gaskets (12); glow plug (10) and studs (14 and 15) need not be removed unless replacement is required.
- (8) Remove nuts (27, Figure 8-30, Sheet 7 of 10) from studs (30), remove exhaust muffler (28) and gaskets (29). Studs (30) need not be removed unless replacement is required.
- (9) Figure 8-30, Sheet 2 of 10, remove screws (16, 22, and 30). Separate front half of the belt guard (34) and remove. Loosen screw (7, Figure 8-30, Sheet 10 of 10) and remove drive belts (25, Sheet 9 of 10). Remove rear half of belt guard.
- (10) Remove nuts (5 and 8, Figure 8-30, Sheet 10 of 10), washers (6, 9) and screws (7 and 10). Remove alternator (4) from engine. Remove screws (12), washers (13) and alternator bracket (11) from crankcase.
- (11) Figure 8-30, Sheet 10 of 10. Remove mounting screws (2) and lock washers (3) from starter motor (1). Disengage starter motor and remove from engine.
- (12) Figure 8-30, Sheet 3 of 10. Remove tube clip (30), disconnect fuel line No. 1 (31) and fuel line No. 2 (32). Remove fluid passage bolts (25), copper gaskets (26) and spacer (27). Remove fuel line (11).
- (13) Remove fluid passage bolt (1), copper gaskets (2) from fuel pump (4); remove screws (3) from fuel pump (3) and remove from engine. Remove o-ring (5).
- (14) Unscrew fluid passage bolt (7) from fuel filter (21). Remove fuel line (6) and copper gaskets (8).
- (15) Remove fluid passage bolt (9), copper gaskets (10 and 12). Remove fuel line (11); tag for re-assembly purposes. Remove banjo bolt (14), fuel line (16), leak off to tank, copper gaskets (15), banjo bolt (17), copper gaskets (18) and fuel line to shut off valve (19).
- (16) Remove screws (20) from fuel filter (21) and remove filter assembly, screws (22) and spacers (24), remove fuel filter mounting bracket (23). mounting bracket (23).

(17) Figure 8-30, Sheet 7 of 10. Remove nuts (64), lock washers (65), injector strap (66). Do not remove studs (67) unless replacement is necessary. Remove fuel injector (29, Figure 8-30, Sheet 3 of 10) and seal washer (28) from cylinder head.

CAUTION

If shims (35) are removed, care should be taken in replacing the exact number and size of shim removed.

NOTE

When removing injection pump push throttle lever completely forward (full speed position). DO NOT pull extra fuel button.

- (18) Remove nuts (33) from injection pump (34), push throttle lever full forward (drive end) and remove pump. Remove shims (35), guide plate (36) and gasket (37). Overflow valve (38) and studs (39) need not be removed unless replacement is required.
- (19) Figure 8-30, Sheet 7 of 10. Remove screws (1) and lifting straps (2). Remove screws (3) from head cover (4), remove covers (4). To disassemble decompression subassembly proceed as follows:
- (a) Remove clip (9), plug (12), spring (11) and ball (10) front cover (4).
- (b) Remove shaft (6) from cover (4).
- (20) Unscrew nuts (14) from studs (25). Remove each rocker arm subassembly. Using a pair retaining ring pliers (Table 2-1), remove retaining ring (15) and shim (16) from rocker arm bracket (24). Remove bushing (20), nut (18), and adjusting screw (19) from rocker arm (17). Using retaining ring pliers, remove retaining ring (15) and shim (16) from bracket (24), and inlet rocker (23) off bracket (24). Remove bushing (20), nut (18), and adjusting screw (19) from rocker arm (23). Repeat procedure for other rocker arm subassembly. Adjusting nut (21) and screw (22) need not be removed except for replacement purposes. Remove studs (25) from cylinder heads.

- (21) Remove screws (26, 42 and 61, Figure 8-30, Sheet 9 of 10), lockwashers (27, 44, 62) and nuts (43). Loosen screws (31) and nuts (33) and remove blower duct (28). Remove screws (40, 45), washers (41, 46); Figure 8-30, Sheet 6 of 10. Remove screws (33) and nuts (34). Re-move rear duct section. Remove screws (35, 38) and nut (36). Remove cooling ducts (37, 39 and 40).
- (22) Remove screws (24, Figure 8-30, Sheet 8 of 10), nuts (20), washers (21, 22) and plate (25). Remove blower duct from engine.
- (23) Remove screws (2), lockwasher (3), outer ring (4), screen (5), and inner ring (6). Unscrew and remove nut (7), washer (8), bolt (9), sheave (10), fan (11), washer (12) and spacer (13). Drive out shaft (16), remove ball bearing (15) and spacer shaft (14). Remove inner retaining ring (17), ball bearing (18) and retaining ring (19).
- (24) Figure 8-30, Sheet 4 of 10. Unscrew and re-move nuts (1 and 2), and washer (3) attaching cylinder heads (50, Figure 8-30, Sheet 7 of 10) to engine. Remove push rods (26). Remove cylinder head (50) and gasket (31). Using a valve spring compressor (Table 2-1), compress each valve spring (42) and remove two lock cones (40) from each valve (47 and 48). Remove spring cup (41), external valve spring (42), internal valve spring (43), spring seat (44), and spring cap (45) from valves (47 and 48). Re-move valves (47 and 48) from cylinder head subassembly (50). Remove two valve guides (49) from cylinder head (50). Repeat steps above for other cylinder head group. Remove one gasket (51) from each cylinder (50).
- (25) Remove push rods (26) and push rod tubes (31) from crankcase. Remove o-ring (34), ring (35) pressure spring (32), pressure ring (33) and origin (34) from each push rod tube. Unscrew nuts (36), remove tube guide plate (37) and gasket (38). Studs (39) need not be removed unless replacement is required.
- (26) Rotate engine work stand so that engine fly-wheel is pointing down.
- (27) Figure 8-30, Sheet 6 of 10. Unscrew and re-move sieve (63), o-ring (64), and washer (65). Unscrew and remove cap (57), spring (58),
- (59), disc (60), ball (62) and o-ring (61).
- (28) Pull cylinder (4, Figure 8-30, Sheet 4 of 10) from crankcase. If necessary, remove studs (6). Using retaining ring pliers (Table 2-1), remove two retaining rings (7) from piston (9). Push piston pin (8) from piston (9). Remove piston (9) from connecting rod (17). Remove the ridge type ring (10), compression ring (11), stepped scrapper ring (12), and oil control ring (13) from piston (9). Unscrew and remove two socket head screws (14) from connecting rod (17). Remove rod end cap and connecting rod from crankcase. It is not necessary to remove bearings (14 and 16) unless damaged. Repeat procedure for the cylinder and piston group.
- (29) Position engine in the horizontal plane, (see Figure 8-30, Sheet 6 of 10). Remove screws (16), lock washers (69), large side cover (70) and gasket (71). Unscrew and remove screws (72), lock washers (73), fuel feed pump cover (74), and cover gasket (75).
- (30) Figure 8-30, Sheet 2 of 10. Remove screw (37) and crank handle support (38) from governor housing (9, Figure 8-30, Sheet 5 of 10).
- (31) Figure 8-30, Sheet 4 of 10. Unscrew and re-move screw (18) and lock washer (19) from sheave (20). Pull sheave off over pins (20a).

NOTE

Alternate tightening of screw on extractor tool and rapping of various points on the governor housing (9) will facilitate removal of the governor housing (9).

- (32) Remove screws (3 and 4, Figure 8-30, Sheet 5 of 10) from governor housing (9). Prior to re-removal of the governor housing attach special extractor tool No. 26, Figure 2-1 and remove governor housing (9). Remove oil seals (1 a, 1 lb). If ball bearing (11) is to be removed, heat the governor housing (9) to 800C (1 75°F) and press ball bearing from the housing.
- (33) Figure 8-30, Sheet 4 of 10. Unscrew and re-move nut (51), gear wheel (52) from oil pump (53). Remove screws (48 and 50), lock washers (47 and 49). Remove oil pump (53) from crankcase. Using gear wheel puller (Figure 2-1, tool No. 27) disengage gear wheel (21) from

crankshaft. Remove key (40). Unscrew and remove nut (51), gear wheel (52) from oil pump (53).

(34) Figure 8-30, Sheet 7 of 10. Fix cam follower (tappets) (64) away from cam lobes using tool No. 15, Figure 2-1, or equivalent. Pull cam from crankcase.

CAUTION

Care should be taken when disassembling springs (52) that shims (53) and balls (55) are not lost.

- (a) Remove springs (52), spring holder (53), shims (54) and ball (55). Remove screws (56), lock washers (57), spring support (58), brackets (59) and weights (60).
- (b) Unscrew and remove screws (61), lock washers (62), starter sleeve (63), gear wheel (66) and pin (67). Do not remove caps (64) or pin (65) from starter sleeve (63) unless damaged and replacement is re-quired.

NOTE

Before removing extra fuel device, cut and re-move safety wire secured on threaded pins located directly above extra fuel device (66). Loosen threaded pins.

- (35) Figure 8-30, Sheet 6 of 10. Using socket wrench (tool No. 10, Figure 2-1) unscrew and remove extra fuel device (66). Remove o-rings (67) from extra fuel device (66).
- (36) Figure 8-30, Sheet 3 of 10. If throttle lever (42) has not been removed, unscrew and remove screws (40), and lock washers (41), remove lever (42).

NOTE

Remove screws (43) with care, shims and spacers are behind tension plate (47).

- (37) Unscrew screws (43). Remove tension plate (47), shims (44) and spacer (45). Remove protective cap (48), adjusting screws (49) and locknuts (50).

- (38) Remove clip (57) from governor lever (58), detach spring (56) and remove screws (60), washers (61), support (62), spring (56) and support guide (63). Disconnect the control rod (59) from the governor lever (58), and remove the control rod through the side of the crank-case.

- (39) Remove the pin (51) securing the throttle shaft (52) and connecting lever (55) together. Re-move the spring (54) from shaft (52). Remove the retaining clip (55b) securing the connecting lever (55) and governor lever (58) together. Re-move throttle shaft (52) from crankcase. Re-move o-ring (53) from shaft.

- (40) Figure 8-30, Sheet 5 of 10. Unscrew and re-move screws (13), washers (14). Disengage housing (15) from engine flange (20). Remove flywheel mounting screws (16) and remove fly-wheel (17). Do not remove gear ring (18) from flywheel (17), unless damaged. Remove screws (19), detach engine flange (20) from crankcase.

- (41) Figure 8-30, Sheet 4 of 10. Remove socket head screws (23) from flywheel hub (24). Re-move flywheel hub (24) and bushing (25). Re-move hex nuts (26), lock washers (27) from bearing flange (38). Using thrust screws, break flange away from crankcase and remove flange (28). Remove gasket (29); studs (30) need not be removed unless damaged.

- (42) Remove oil seal ring (34) from bearing flange (28), press out bearing (35). If present, remove buffer ring (37) and shim (38).

NOTE

Do not mix counterweights. Weights have been balanced on crankshaft.

- (43) Unscrew and remove screws (38) and washers (38a) from the top of the crankcase that holds the bearing support (38b) to the case. Pull bearing support (38b), counterweights (43) and crankshaft (45) from the crankcase. Remove screws (37) from bearing support (38b). Separate bearing halves and remove crankshaft bearings (39). Press out or knock out main bearings (22a) from crankcase.

- (44) To remove rear cam bearing (62, Figure 8-30, Sheet 7 of 10), remove cover (63) and press out new cam bearing (62).

NOTE

Care should be taken to assure that spring (45) is not lost when breather cover (43) is removed.

(45) Figure 8-30, Sheet 6 of 10. Unscrew and re-move nut (41) and washer (42). Disengage breather cover from crankcase and lift off stud (51). Remove spring (45), plate (46), diaphragm (47), valve breather plate (48), screen (49), intermediate plate (50), stud (51) and hex nut (52). Oil splash plate (53) need not be removed unless the plate is to be replaced. Remove gasket (44) from cover (43).

(46) Figure 8-30, Sheet 9 of 10. Remove nuts (34), washers (35) from oil cooler mounting studs (61) and remove cover panel (36); remove mounting screws (50). Oil cooler tubes (54) with oil pipe right (51) and oil pipe left (53) may be pulled from the mounting studs (61) as a unit. Remove oil pipe right (51) and oil pipe left (53) from tubes (51) and remove o-ring (55) from each. Remove gasket (52) from crankcase. Studs need not be removed unless repair is necessary.

b. Cleaning. Refer to paragraph 6-3.a for general cleaning instructions.

- (1) Parts that will be repainted may be cleaned with steam. Avoid use of water or steam on electrical components and wiring.
- (2) After cleaning, refinish affected painted areas where required in accordance with T.O.35-1-3.
- (3) Remove caked grease or dirt with a non-metallic brush after immersing part in solvent. Scrape carbon, grease, and old gasket material from affected surfaces.
- (4) Clean cylinders and pistons with care. Do not mar or scratch contact or seating surfaces. Piston ring grooves must be cleaned with care so as not to scratch or mar grooved surfaces.

CAUTION

Do not immerse prelubricated bearings in dry cleaning solvent prior to installation.

(5) Clean bearings by immersing them in dry cleaning solvent per Federal Specification P-D-680, Type II, and air dry.

c. Inspection. Refer to paragraph 6-3.b for general inspection instructions.

- (1) Parts with dimensions listed in Table 6-1, Table of Limits shall be measured to ascertain accept-ability for repair and assembly.
- (2) Cylinder head covers (4, Figure 8-30, Sheet 7 of 10) for damaged contact surface.
- (3) Rocker arm bushings (20, Figure 8-30, Sheet 7 of 10). Refer to Table 6-1.
- (4) Adjusting screws (19) for worn ball heads.
- (5) Rocker arms (17 and 23) for worn radius (flats). Refer to Table 6-1.
- (6) Shaft on rocker arm brackets (24) for wear.
- (7) Valve springs (42 and 43) for cracks, breaks and set. Refer to Table 6-2.
- (8) Valve guides (49) for wear. Refer to Table 6-1. Cylinder heads (50) for damaged contact surfaces.
- (9) Valve seats in cylinder heads (50) to see if valve seats may be recut. Refer to Table 6-1.
- (10) Cylinder heads (50) for cracks between valve seats and injector aperture.
- (11) Cylinders (4, Figure 8-30, Sheet 4 of 10) for evidence of piston seizure or scores on the running surface. Refer to Table 6-1.
- (12) Piston ring (10, 11, 12, and 13) sets for wear.
- (13) Pistons (9) for evidence of seizure or cracks in the area between the ring grooves.
- (14) Piston ring grooves for wear.
- (15) Piston pin bushing (16) for wear. Refer to Table 6-1.
- (16) Connecting rods (17) for blue coloration or incline.

- (17) Crankshaft bearings (22a, 35 and 39) for wear and scoring. Refer to Table 6-1.
- (18) Oil pump (53), shaft and gearwheel (52) for wear.
- (19) Figure 8-30, Sheet 3 of 10. Control rod springs (54, 55a and 56). Connecting lever (55), governor lever (58) and control rod (59) for wear or damage.
- (20) Crankshaft (45, Figure 8-30, Sheet 4 of 10) for wear and scoring. Refer to Table 6-1.

d. Repair or Replacement. Refer to paragraph 6-3.c for general repair or replacement instructions.

- (1) Replace parts that do not meet the dimensional tolerances listed in Table 6-1.
- (2) Replace cylinder head covers (4, Figure 8-30, Sheet 7 of 10) with damaged contact surfaces.
- (3) Replace defective rocker arm bushings (20, Figure 8-30, Sheet 7 of 10).
- (4) Replace defective adjusting screws (19).
- (5) Replace defective rocker arms (17 or 23).
- (6) Replace defective rocker arm bracket (24).
- (7) Replace a defective valve spring (42 or 43).
- (8) Replace worn valve guides (49).
- (9) Replace cylinder head (50) with worn contact surface.
- (10) Replace cylinder heads (50) if valve seats can not be recut.
- (11) Replace cylinder head (80) if cracked.
- (12) Replace worn piston rings (10, 11, 12 and 13). Replace rings as a set.
- (13) Replace pistons (9) that have worn piston ring grooves beyond the limits set in Table 6-1.
- (14) Replace damaged piston (9).
- (15) Replace piston pin bushing (16) that is worn beyond the limits set in Table 6-1.

- (16) Replace a defective or worn connecting rod (17).
- (17) Replace bearings (22a, 35 and 39) that are scored or worn beyond the limits designated in Table 6-1.
- (18) Replace oil pump (53) if shaft is worn. Replace gear wheel (52) if teeth are worn or cracked.
- (19) Replace defective springs (54, 55a, and 56), damaged levers (55 and 58) and control rod (59).
- (20) Replace crankshaft (45, Figure 8-30, Sheet 4 of 10) if worn beyond permissible limits.

e. Assembly. To assemble the diesel engine assembly proceed as follows:

NOTE

Before o-rings (55.) are installed, the contact area should be lightly ground.

- (1) Figure 8-30, Sheet 9 of 10. If stud (61) was re-moved, screw studs (61) into crankcase, install gasket (52) over stud (61). Place o-ring (55) for cooler tubes (54) into oil pipe right (51) and oil pipe left (53). Install the oil cooler tubes (54) into oil pipe right (51) and oil pipe left (53) and mount on crankcase using stud (61), washer (35), nut (34) and screws (50).
- (2) Install support (37), cover (36) and spacer (38, 39) using washers (30) and screws (29).
- (3) Figure 8-30, Sheet 6 of 10. Screw hex nut (52) into stud (51), screw stud (51) into crankcase through oil splash plate (53). Install intermediate plate (50), screen (49), breather plate (48), diaphragm (47), plate (46) and spring (45) over stud (51). Install gasket (44) into cover (43) and spring (45) over stud (51). Install gasket (44) into cover (43) and install cover (43) over stud (51) using washer (42) and nut (41).

CAUTION

Oil holes in bearings must line up with holes in crankcase during installation of any bearing.

- (4) Using tool No. 25, camshaft bearing punch (Figure 2-1), install camshaft bearings (62, 62a, Figure 8-30, Sheet 7 of 10). Install cover (63) using tool No. 30, mounting tool for main bearing (gov. end), install main bearing (22a, Figure 8-30, Sheet 4 of 10).
- (5) Install counterweights (43) onto crankshaft (45) using washers (42) and screws (41). Torque screws (41) to 81 ft-lbs (110 Nm). Mount crankshaft bearings (39) into bearing support holes (38b). Align oil hole and attach bearing halves to crankshaft (45) using screws (37). Torque to 81 lbs-ft (110 Nm).
- (6) Insert crankshaft (45) into crankcase. Attach bearing support (38b) to crankcase using washers (38a) and screws (38). Torque screws (38) 81 lbs-ft (110 Nm).
- (7) Install crankshaft bearing (35) into bearing flange (28) using tool No. 29, mounting tool for main bearing (flywheel end). Press in oil seal ring (34) using tool No. 28, oil seal punch bearing flange. If studs (30) were removed, install studs (30), gasket (29), bearing flange (28), washer (27) and nuts (29). Check end play of crankshaft (0.2 mm - 0.7 mm). If the tolerance does not check correctly, remove the bearing flange (28) and insert the proper size shim (31). Reinstall bearing flange and torque nuts (26) to 36 lbs-ft (50 Nm).
- (8) Fit bushing (25) in proper hole in end of crankshaft (45). Install buffer ring (32). Match flywheel hub (24) to bushing (25) and attach flywheel hub (24) to crankshaft (45) using screws (23). Torque screws (23) to 103 lb-ft(140 Nm).
- (9) Figure 8-30, Sheet 5 of 10. Using screws (19), attach engine flange (20) to crankcase. If gear ring (18) was removed from flywheel (17), heat gear ring evenly all around circumference to 300-350°F (1490C + 1770C). Place gear ring onto flywheel tapping gently to place gear ring as needed.
- (10) Install flywheel (17) to flywheel hub using alignment pin to assure proper flywheel (17) positioning and attach using screws (16). Torque screws (16) to 107 lb-ft (145 Nm).
- (11) Figure 8-30, Sheet 3 of 10. Install o-ring (53) onto throttle shaft (52). Insert throttle shaft (52) into crankcase, positioning the slot in shaft toward the non-drive end of the crankcase. Attach spring (54) to throttle shaft (52). Position lever spring (55a) onto the shaft of the connecting lever (55). Install the governor lever (58) onto the connecting lever (55) and secure with retaining ring (55b). Apply clockwise tension to spring (55b) by rotating governor lever over full revolution. Position connecting lever (55) onto shaft (52) and secure by installing pin (51). Connecting lever (55) must be easily moveable, after installation.
- (12) Insert control rod (59) through side of crankcase. Install support (62) and support guide (61) using lockwashers (61) and screws (60). Position control rod (59) on guide support (61). Attach governor lever (58) to control rod (59) and secure with retaining clip (57). Attach spring (56) to support (62) and control rod (59).

NOTE

Tension adjustments on throttle shaft movement can be made by the adding or subtracting of shims (42).

- (13) Install locknuts (50) on screws (49); install screws (49) into side of crankcase next to throttle shaft (52). Be sure slot on throttle shaft is toward the non-drive end of the crankcase. Do not tighten adjusting screws at this time. Install shims (44), spacers (45), tension plate (47) and screws (43). Attach throttle lever (42) to throttle shaft (52) using lockwashers (41) and screws (40). Throttle lever (42) should point of the downward position when installed correctly.
- (14) Figure 8-30, Sheet 6 of 10. Install o-ring (67) onto extra fuel device (66). Using socket wrench (Tool No. 10, Figure 2-1) screw extra fuel device (66) into crankcase.
- (15) Figure 8-30. Sheet 7 of 10. To assemble the governor onto the camshaft proceed as follows:
 - (a) Position gear wheel (66) so that the face stamped with "0/15" is facing outward. Attach the camshaft (68), gear wheel (66) and starter sleeve (63) with lockwashers (62) and screws (61). Do not tighten screws (61) at this time. Install pin (67)

and tighten screws (61). Torque screws (61) to 21 lb-ft (35 Nm).

- (b) Position the weights (60) and brackets (59) on the inside face of gear wheel (66). The heavy chamfered edges of the brackets must face toward the center of the gear wheel. Position spring support (58), install lockwashers (57) and screws (56). Hand tighten screws (56) at this time.

CAUTION

The distance between the spring plates on the spring support (58) and the camshaft must be equal on both sides of the camshaft before screws (56) are tightened. See Figure 6-28.

- (c) Tighten screws (56). Torque screws (56) to 21 lb-ft (35 Nm).
- (d) Place shim (34) in inner spring plate (53), using a light grease attach ball (55) to inner spring plate (53). Place the inner spring plate over one end of spring (52). Using care, insert the open end of the spring into the outer spring plate (58) and press spring assembly into recess in weights (60) until the ball (55) snaps into place. Repeat process for other side.

NOTE

There should be no tension on governor springs; weights should move freely and should have free movement of 1.0 - 1.5 mm before spring tension is noted. Adjust movement of weights by use of shims (54) to obtain correct amount of movement (see Figure 6-28).

- (16) Install governor and cam (66) into crankcase. Remove clamp (tool No. 15, Figure 2-1) holding cam followers (tappets) away from cam shaft.

CAUTION

Oil pump (53) must have free movement after installation.

NOTE

Make sure gear wheel (21) on crankshaft and oil pump gear wheel (52) mesh correctly when crankshaft gear wheel (21) is installed.

- (17) Figure 8-30, Sheet 4 of 10. Using screws (48, 50), lock washers (47, 49) attach oil pump (53) to crankcase. Attach oil pump gear wheel (52) to oil pump shaft using nut (51). Insert key (40) on crankshaft. Heat gear wheel (21) to 1000C (2100), line gear wheel up with key (40) and knock gear wheel (21) onto crank-shaft.

- (18) Figure 8-30, Sheet 5 of 10. Heat governor housing (9) to 800C (1750F) and press in ball bearing (11). Install oil seal (1 la) and oil seal (11 b) in governor housing (9). Attach gasket (12). Prior to mounting governor housing, install tool No. 31, bushing for mounting governor housing (crankshaft) and tool No. 32, bushing for mounting governor housing (camshaft). Insert guide pin (10) and install governor housing (9) to crankcase (32).

- (19) Install pins (20a, Figure 8-30, Sheet 4 of 10) in end of crankshaft. Fit sheave (20) and attach sheave to crankshaft using lockwasher (19) and screw (18). Torque screw (18) to 88 lb-ft (120 Nm).

- (20) Figure 8-30, Sheet 2 of 10. Using screws (37) attach crank handle support (38) to governor housing.

- (21) Figure 8-30, Sheet 6 of 10. Using screws (72) and lock washers (73) attach gasket (75) and fuel feed pump cover (74) to crankcase. Attach gasket (71) and large side cover (70) to crank-case using lock washers (69) and screws (68).

CAUTION

Oil holes in rod bearings and connecting rod must be in alignment.

- (22) Figure 8-30, Sheet 4 of 10. Press top end rod bearing (16) into rod (17). Position bearings (15) in rod can and rod. Insert rods (17) into crankcase and secure to crankshaft and secure to crankshaft using screws (14). Torque screws (14) to 55 lb-ft (75 Nm).

NOTE

Connecting rods (17) should be mounted so that the identification numbers on the rod halves point to the blower side of the engine.

NOTE

Apply clean oil to threads and bottom of screw head of screws (14) before torquing screws.

NOTE

insure that the small valve recess in the piston (9) head points to the flywheel end of the engine.

NOTE

A piston ring kit is available, replace all piston rings if any ring needs replacement.

- (23) Using a ring spreader (Tool No. 22, Figure 2-1). Install oil control ring (13), stepped scrapper ring (12), compression ring (11), and wedge type ring (10) on pistons (9). Place retainer ring (7) in groove in piston (9). Attach piston (9) to connecting rod (17) with piston pin (8). Install retaining ring (7) in piston (9).

NOTE

Before cylinder (4) is installed, position ring gaps 90° apart.

- (24) If cylinder studs (6) had been removed, install in crankcase. Using tool No. 23, piston ring clamp, carefully install cylinders (4) over pistons (9).
- (25) Figure 8-30, Sheet 6 of 10. Place o-ring (61) over cap (57), install disc (60), pin (59), and spring (58) in cap (57), install ball (62). Install in crankcase. Install washer (65) o-ring 64 on sieve (63). Screw sieve into side of crankcase.

NOTE

The wider machined side of the table guide plate (37) should be mounted closest to the cylinders.

- (26) Figure 8-30, Sheet 7 of 10. If studs (39) were removed, Install into crankcase. Place gasket (38) and tube guide plate (37) over studs (39). Secure with nuts (36).

NOTE

New valve guides (49) shall be reamed out us-Ing valve guide reamer (tool No.36, figure 2-1).

- (27) If valve guides (49) were removed from cylinder head (50) press in new valve guides (49) using Tool No. 20, valve guide insertion tool. Mini-mum insertion force required 220 lbs.) Insert valves (48, 47) in head (50). Using Tool No. 21, punch, seal cap, install seal caps (46), large washer (45), small washer (44), internal and external springs (43, 42), spring clip (41) and lock covers (40). Apply a light coat of sealing com-pound, Military Specification, MIL-S46163 or equal to threads of studs (25). Install studs (25), bracket (24) and secure with nuts (14). Torque collar nuts (14) to 33 lb-ft (45 Nm).

NOTE

Use only one gasket (51) of correct thickness per cylinder.

- (28) Using cylinder clamp (Tool No. 37, Figure 2-1) clamp cylinder so that it is stationary when flywheel is turned over. Place timing gauge clamp (Tool No. 16) on measuring bridge (Tool No. 17); place the measuring bridge on a flat plate and insert timing gauge (Tool No. 9) into clamp. When gauge shows 3 ro 4 mm pre-tension, clamp gauge in place. Place measuring bridge with clamp and gauge on top of cylinder. Check dimension between piston at TDC (top dead center) and top of cylinder head. Correct bumping clearance is 0.043 to 0.051 inches (1.1 to 1.3 mm). Total thickness of the gasket (51) and distance between piston and top of cylinder should equal bumping clearance tolerances.

CAUTION

Make sure that push rod tubes (31) are properly seated when assembled.

- (29) Lightly grease gasket (51) and place on top of cylinder. Place o-ring (34), pressure ring (33), spring (32) and tubes (31) into tube guide plate (37). Place o-ring (34), intermediate ring (35) in cylinder head (50). Install cylinder head (50) over studs and position tubes (31) into recesses in cylinder head (50). Install exhaust manifold studs (30) in cylinder heads (50).

NOTE

Prior to torquing cylinder head nuts, tighten enough to where cylinder heads are still moveable. Fit the exhaust manifold (28) to the cylinder heads. This correctly positions the cylinder heads. Tighten and torque cylinder head nuts as noted.

NOTE

Place clean oil on stud (6) threads and bottom of nuts and washers, torque to valve noted.

(30) Figure 8-30, Sheet 4 of 10. Install washers (3) and cylinder head nuts (1 and 2) on studs (6). Torque nuts to 36 lb-ft (50 Nm). Release tension on studs (6) by turning back slightly on nuts (1, 2). Insert push rods (26, Figure 8-30, Sheet 7 of 10) through cylinder heads (50) into push rod tubes (31).

(31) Press rocker arm bushings (20) into rocker arms (23, 17). Install adjusting screw (14) and nut (18) in rocker arms (17, 23). Place rocker arms (17, 23) onto rocker arm brackets (24). Install shims (16) as required to center rocker arms (23, 17) over valve stems; install retainer clips (IS). Adjust tappet clearance cold. Rotate engine until resistance to compression is noted, loosen nut (18), check clearance 0.004 inches (0.11mm) with feeler gauge. A slight resistance should be felt when feeler gauge is pulled through between the rocker arm and valve stem. Adjust by turning screw (14). To tighten, screw nut (18).

CAUTION

Care should be taken not to damage o-rings (8) when installing shaft (6) into head cover (4).

(32) Install o-rings (8) on shaft (6), install shaft (6) into valve cover (4). Install one retainer clip (19) at base of shaft (6), and the other at the end of the shaft. Place ball (10) and spring in cover (4) and install threaded plug (12).

(33) Rotate flywheel until compression resistance is noted. Using tool No. 38, adjusting gauge, (Figure 2-1), determine if the top of pin "a" on rocker arm (23) falls between the minimum of maximum allowable values. (See Figure 6-11 and 6-12).

NOTE

When pressure pin (22) is crimped in place the height will decrease approximately .004 inches (0.10 mm).

(34) If a new pressure pin (22) and spacer (21) are required, place new pressure pin in rocker arm, using spacers (21) to adjust for proper height requirements for distance "B" (min. 34.8 mm max. 35.3 mm). Using tool No. 39, riveting tool, attach new pressure pin (22) and spacer (21) to rocker arm (23). (See Figure 6-11.) Proper tool set up and adjustment will help make a tight pressure pin seal to the rocker arm.

(35) Place gaskets (29) over studs (30), install exhaust muffler (28) over studs (30) and secure with nuts (27). Install cover gaskets (13), valve covers (4) and secure covers to cylinder head using screws (3). Attach lifting straps (2) to cylinder heads using screws (1).

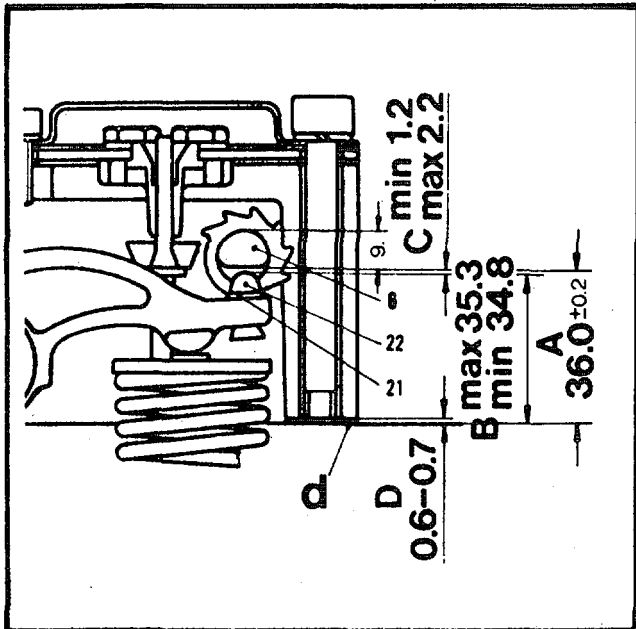

Figure 6-11. Compression Adjustment

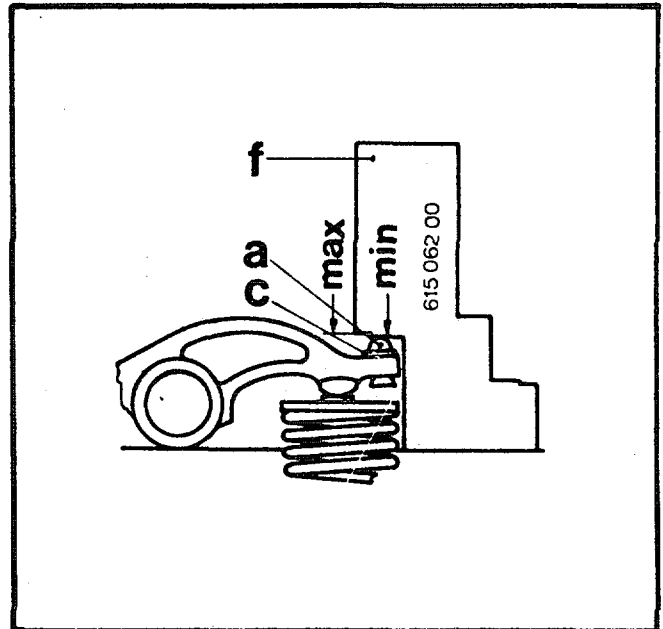

Figure 6-12. Compression Adjustment Check

- (36) If injection pump studs (39, Figure 8-30, Sheet 7 of 10) were removed from crankcase, install studs (39), place gasket (37), guide plate (36) and shims (35) over studs (39). Place fuel lever in the forward position (toward drive end) and install injection pump (34). Fasten with nuts (33).
- (37) Figure 8-30, Sheet 3 of 10. Place seal washers (28) into fuel injector cavity. Install fuel injector (29) into cylinder heads, the injector strap (66, Figure 8-30, Sheet 7-10) over studs (67) and fuel injector (29, Figure 8-30, Sheet 3 of 10). Install lock washers (65) and nuts (64, Figure 8-30, Sheet 7 of 10). Torque nuts (64) to 20 lb-ft (15 Nm).
- (38) Figure 8-30, Sheet 8 of 10. Install outer retaining ring (19) in blower housing (1), press in ball bearing (18) using tool No. 33, punch for blower assembly, install inner retaining ring (17). Insert tool No. 35 through the rear of the blower assembly and mount assembly on its side. Using tool No. 34, bolt for blower-assembly, position and knock in blower shaft (16). Place spacer shaft (14) over blower shaft (16), using tool No. 33, punch for blower assembly, knock ball bearing (15) into blower housing. Install spacer washer (13), washer (12), fan (11) and sheave (10) on stub of shaft (16), insert bolt (9) through shaft (16), and secure with washer (8) and nut (7).

NOTE

Make certain that grooves in outer ring (4) are positioned properly when installed.

- (39) Assemble inner ring (6), screen (5) and outer ring (4). Attach to blower housing (1) using lock washers (3) and screws (2).
- (40) Install studs (23) into crankcase, Install blower assembly (1) onto crankcase and attach using support plate (25), screws (24), washers (22, 21) and nuts (20). Position cooling ducts (40 and 37) between cylinders, and attach using screws (35) and nut (36). Position duct (39) and attach to duct (40) with screw (33) and nut (34). Install screws (38), Position rear duct (47, Figure 8-30, Sheet 9 of 10), Attach to crank-case using washers (46, 41, Figure 8-10, Sheet 9 of 10), screws (45, 40), Install screw (33, Figure 8-10, Sheet 6 of 10) and nut (34)
- through duct (40) and duct (47, Figure 8-10, Sheet 9 of 10). Position blower duct (28). Attach to blower housing using nuts (43), washers (44) and screws (42); attach blower housing (28) to cylinder heads using washers (27) and screws (26) install screw (62) and washer (61) in blower housing. Tighten nuts (33) and screws (31).
- (41) Figure 8-30, Sheet 3 of 10. Using spacers (24) and screws (22), install fuel filter mounting bracket (23) to rear cylinder head. Attach fuel filter assembly (21) to bracket (23) with screws (20).
- (42) Place copper gasket (18) over banjo fitting (17), insert banjo fitting (17) through fuel line (19). Install copper gasket (18) on fitting (17) and screw fitting (17) into fuel filter (21), Position copper gaskets (15) on either side of leak off fitting (16), install banjo bolt (14) through the gaskets (15) and fitting (16); screw banjo bolt (14) into banjo fitting (17). Place washer (10) on banjo bolt (9). Insert banjo bolt (9) through fuel line (11), gasket (12), fuel line (13), gasket (12) and screw banjo bolt (9) into bolt (14).
- (43) Install one copper gasket (8) on banjo bolt (7), insert bolt (7) into fuel line (6) and a gasket (8) on bolt (7). Screw bolt (7) into intake side of fuel filter assembly (21). Using banjo bolts (25) install copper gasket (26) leak off *line* (11), copper gasket (26), spacer (27) and a copper gasket (26). Screw the banjo bolts (25) into each fuel injector (29). Torque banjo bolts (25) to 29 lb-ft (40 Nm),
- (44) Attach solenoid mounting bracket (72) to crankcase using screws (71). Connect solenoid wire (69) to shut off valve (70) and assembly protective cap (68) to valve (70) base. Using screws (66) and washers (67) attach valve (70) to mounting bracket (72). Place copper washer (65) onto banjo bolt (64), insert bolt (64) through fuel line (19) and gasket (65), Screw banjo bolt (64) into solenoid valve (70).
- (45) Place a copper gasket (65) over banjo bolt (64), Insert banjo bolt through fuel line (73) and copper gasket (64). Screw banjo bolt (64) into fuel shut off valve (70).
- (46) Remove bypass valve (38), place copper gasket (38a) over valve (38). Insert valve (38) through

banjo fitting of fuel line (73), fit second gasket (38a) on valve (38) and screw valve (38) into injection pump (34).

- (47) Place o-ring (5) onto fuel feed pump (4). Install feed pump (4) on crankcase using screws (3). Place copper gasket (2) over banjo bolt (1), insert bolt (1) through banjo fitting on fuel line (6), place second gasket (2) over bolt (1) and screw bolt (1) into fuel feed pump (4).

NOTE

Torque fuel line No. 1 (31) and No. 2 (32) fittings at the injection pump (34) only at installation. Fuel lines No. 1 and No. 2 (31 and 32) will be torqued at the injector (29) after fuel system has been bled.

- (48) Install fuel line No. 1 (31) and fuel line No. 2 (32). Hand tighten fittings at the injectors (29) only, until after the fuel system has been bled. Tighten fuel line fittings at the fuel injection pump (34), torque the fittings to 30 lb-ft (40 Nm). Attach line clip (30) to fuel lines (31 and 32).

NOTE

Do not tighten nut (5) on alternator support until belts are installed.

- (49) Figure 8-30, Sheet 10 of 10. Insert starter motor (1) into intermediate housing and attach to engine using lock washers (3) and screws (2). Attach alternator bracket (11) to crankcase using lock washers (13) and screws (12). Attach support arm (17) to crankcase using stud (16), washer (20) and nut (19). Attach alternator (4) to lower bracket (11) using screw (10), washer (9) and nut (8). Using screw (7), washer (6) and nut (5), attach upper alternator mount to support arm (17). Position fan cover (16), fan (15), in alternator (4) shaft and install sheave (14).
- (50) Tighten drive belts (25, Figure 8-30, Sheet 9 of 10). Position rear half of belt guard (34, Figure 8-3, Sheet 2 of 10). If spacer screw was removed install spacer screw (35) to crankcase. Position belt guard over belts and install grommet (33), bushing (32), washer (31) and screw (30). Line up the two halves of the belt guard (34) and attach using grommet (21),

washer (18) and screw (16). Attach guard supports (19, 25) and clamps (20, 26 and 28) using screws (16, 22).

- (51) Figure 8-30, Sheet 7 of 10. If removed, replace studs (30). Position gaskets (29) over studs (30), place exhaust muffler (28) over studs (30). Using nuts (27) attach exhaust muffler to cylinder. Figure 8-30, Sheet 2 of 10, screw glo-plug (10) into manifold (11). If studs (15 and 14) were removed install studs (15, 14) into cylinder heads. Position gaskets (12) on studs, and using nuts (13) attach manifold (1) to cylinders. Place lock washers (4) on screws (3). Install screws (3) in air filter (5), place support (7) over screws (3) and gasket (6) over screws (3). Attach air filter (5) to manifold (11) using screws (3). Position rubber ring (9) on air filter (5), and attach support strap (2) to the air filter (5) and support (7). Attach rain cap (1) to air filter (5).

- (52) To time the engine and injection pump, proceed as follows:

- (a) Place the throttle lever (42, Figure 8-30, Sheet 3 of 10) in the full speed position. In this position, the recess in the governor lever in relation to the governor rod should be exactly in the middle of the injection pump hole in the crankcase.
- (b) If the recess in the governor lever is not in the middle of the pump hole, adjust the lever by using tool No. 10, Figure 24, socket wrench to turn the extra fuel button (66, Figure 8-30, Sheet 6 of 10).
- (c) If injection pump (34, Figure 8-30, Sheet 3 of 10) has not been installed in crankcase install shims (35), plate guide (36) and gasket (37), insert injection pump (34) and attach using nut (33).

NOTE

Adjustment steps shall be accomplished on the pump element (facing the injection pump) that is on the left hand side.

- (d) Unscrew and remove delivery valve holder (Figure 8-35), o-ring (2), filling piece (3), shim (4), spring (5), copper gasket (6) and delivery valve (7). Rotate flywheel and

position pump element (9) at its lowest position.

- (e) Replace delivery valve (7) and copper gasket (6) in the injection pump. Screw tool No. 8, adjusting tool for injection pump, into injection pump. Attach threaded pin to timing gauge (tool No. 9) and insert timing gauge into base mount. Adjust gauge for 1 mm of pretension and secure gauge to base mount. Check gauge for free movement.

NOTE

After fuel line is attached to injection pump, fuel should start to flow from the overflow tube on adjusting tool base (tool No. 8).

- (f) Attach fuel line (73) to injection pump (34). Turn flywheel counterclockwise until fuel stops flowing from the overflow tube. Slowly turn the flywheel further until fuel starts to emerge very slightly from the overflow tube. This is the delivery end. The degree marks on the flywheel before top dead center (TDC) must correspond to 120 ± 0.5 .
- (g) If the degree readings do not correspond, adjust injection pump (34) using shims (35). Add shims - delivery end delayed. Subtract shims - delivery end advanced. To obtain the exact thickness of shim (add or subtract). Set dial gauge of tool No. 9 to 0 where it was determined the engine was at the "delivery end." See paragraph (f) above. Turn flywheel until required degree mark is obtained (120 ± 0.5). The indicated difference on the dial gauge is the thickness of the shims that need to be added or subtracted to obtain a properly timed engine.

NOTE

If the fuel emerges slightly from the overflow tube of tool No. 8, when the correct degree reading ($120 + 0.5$) on the flywheel is reached, then correct engine timing for the delivery end has been obtained.

- (h) Adjustment- Extra Fuel Device (66, Figure 8-30, Sheet 6 of 10). At the correct degree reading (120 ± 0.5) and delivery end setting

reset the dial gauge on tool No. 9 to "O." Turn the flywheel in a clockwise rotation until the gauge reading (1.22 mm) is reached. Maintain the flywheel in this position. Fuel should start to flow from the overflow pipe on tool No. 8. If it does not, use tool No. 10, socket wrench, for extra fuel button. Adjust extra fuel button until fuel emerges from overflow tube. Tighten threaded pins (on top of crankcase) to secure the position of the extra fuel device, thread pins with safety wire and seal the wire.

- (53) To bleed the fuel system, proceed as follows:

NOTE

Bleeding of the fuel system should be carried out in two (2) steps.

- (a) Prime system with hand lever on fuel feed pump. As the lever is pumped slowly, loosen bleed screw on top of the fuel filter a little at a time. Fuel should emerge from the bleed screw, bubble free. At this point, tighten bleed screw.

CAUTION

Do not allow engine to start.

- (b) Loosen the nuts (a couple of threads only), on fuel lines 1 and 2 at the injectors, turn the engine over (do not start engine) until fuel emerges and is free of air bubbles. Re-tighten fuel line nuts at injectors and torque nuts to 30 ft-lbs (40 Nm).

6-34. STARTER MOTOR ASSEMBLY (See Figure 8-31). The following paragraphs contain disassembly, cleaning, inspection, repair or replacement, and assembly instructions for the starter motor assembly.

- a. Disassembly. Disassemble the starter motor assembly only to the extent necessary to repair or replace a defective part or parts.
 - (1) Unscrew and remove one hex nut (2) and lock washer (3) attaching field winding (32), terminal lug to bottom solenoid (1), terminal stud. Remove winding (32) lug from solenoid (1).

- (2) Remove three cap screws (8) attaching solenoid (1) to drive end frame (27). Remove solenoid (1) from frame (27).
- (3) Unscrew and remove socket head screws (10) attaching cap (9) to commutator end cap (12). Remove washer, retainer ring, washer, and shim (11) from end of armature (26) shaft.
- (4) Remove one hex nut (14) and flat washer (15) from each stud (13). Detach commutator end cover (12) from field winding housing (31). Using a pair of wire pliers, or equivalent, bend field winding (32) brush (18) holder tabs on brush holder (19) and remove two springs (17) and two brushes attached to field winding (32). Remove brush holder (19) with two brushes (18) from armature (26) shaft. If brushes (18) are worn, bend brush (19) holder tabs and re-move springs (17) and brushes (18).

CAUTION

If insulating tubes over studs (13) are present, care should be taken while pulling frame (27)

with attached studs (13) and armature (26) from housing (31).

- (5) Pull frame (27) with studs (13) and armature (26) from housing (31). Unscrew studs (13) from frame (27). Unscrew and remove nut (23) washer (24) and screw (25) from frame (27). Pull frame (27) forward, also pulling out lever (22). Hold armature (26) slanting downward and slide lever (22) upwards, disengaging the lever (22) from the guide rings on pinion (20). Remove the armature (26) and lever (22) from frame (27).
- (6) Separate bearing ring (11) from snap ring (11) on the drive end of the armature (26) shaft, using an extra deep 5/8" socket. See Figure 6-13. Remove *snap ring* from armature (26) shaft. See Figure 6-14.
- (7) Remove pinion (20) and intermediate bearing (29) from armature (26) shaft. Do not remove windings (32) unless it is necessary. If bearings (21, 28 or 30) are worn or damaged, press bearings from pinion (20), frame (27) or bearing (29).



Figure 6-13. Removing Retainer from Snap Ring

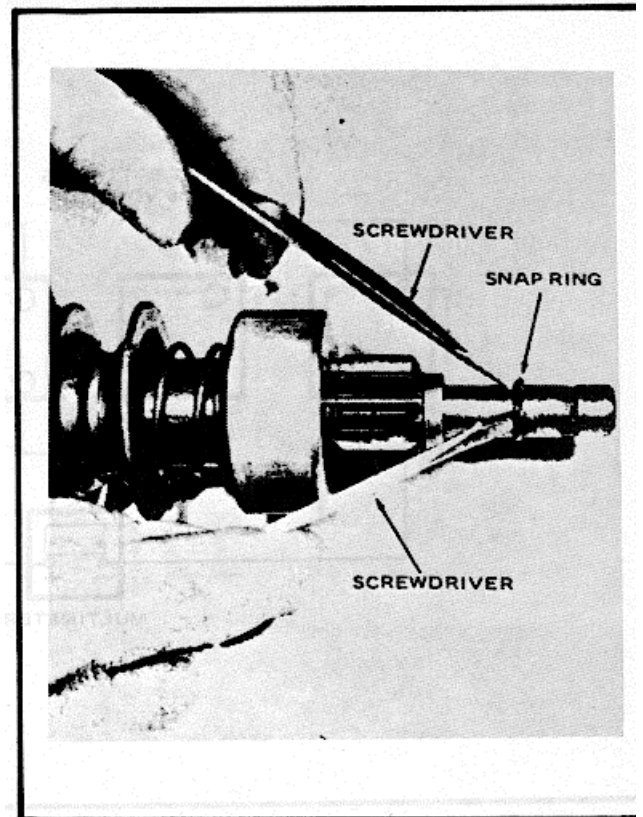

Figure 6-14. Removing Snap Ring from Armature

- b. Cleaning. Refer to paragraph 6-3.a for general cleaning instructions.

CAUTION

Armature, windings, solenoid switch, and pinion drive shall not be cleaned with dry cleaning solvent.

- (1) Allow parts to air dry.

- c. Inspection. Refer to paragraph 6-3.b for general inspection instructions.

- (1) Damaged solenoid.
 (2) Fouled pinion bearing.
 (3) Damaged pinion.
 (4) Test armature and field windings as follows:

- (a) See figure 6-15. Touch multimeter positive lead to each commutator riser bar and jumper lead to the armature.

- (b) If the multimeter indicates any voltage, the armature is grounded and shall be replaced.

- (c) Position armature in growler (Table 2-1), hold growler's test blade parallel to and just above armature.

- (d) Slowly rotate the armature in the growler. If test blade vibrates and is attracted to the armature, the armature is shorted and shall be replaced.

- (e) See Figure 6.16. Touch multimeter positive lead to each field winding lub and jumper lead to winding housing.

- (f) If the multimeter indicates any voltage, any winding is shorted, it shall be replaced.

- (g) Disconnect batteries and perform continuity test on field windings. If any winding is open, it shall be replaced.

- (h) See Figure 6-17. Holding one test lead against the commutator frame touch the other probe to each brush holder in turn.

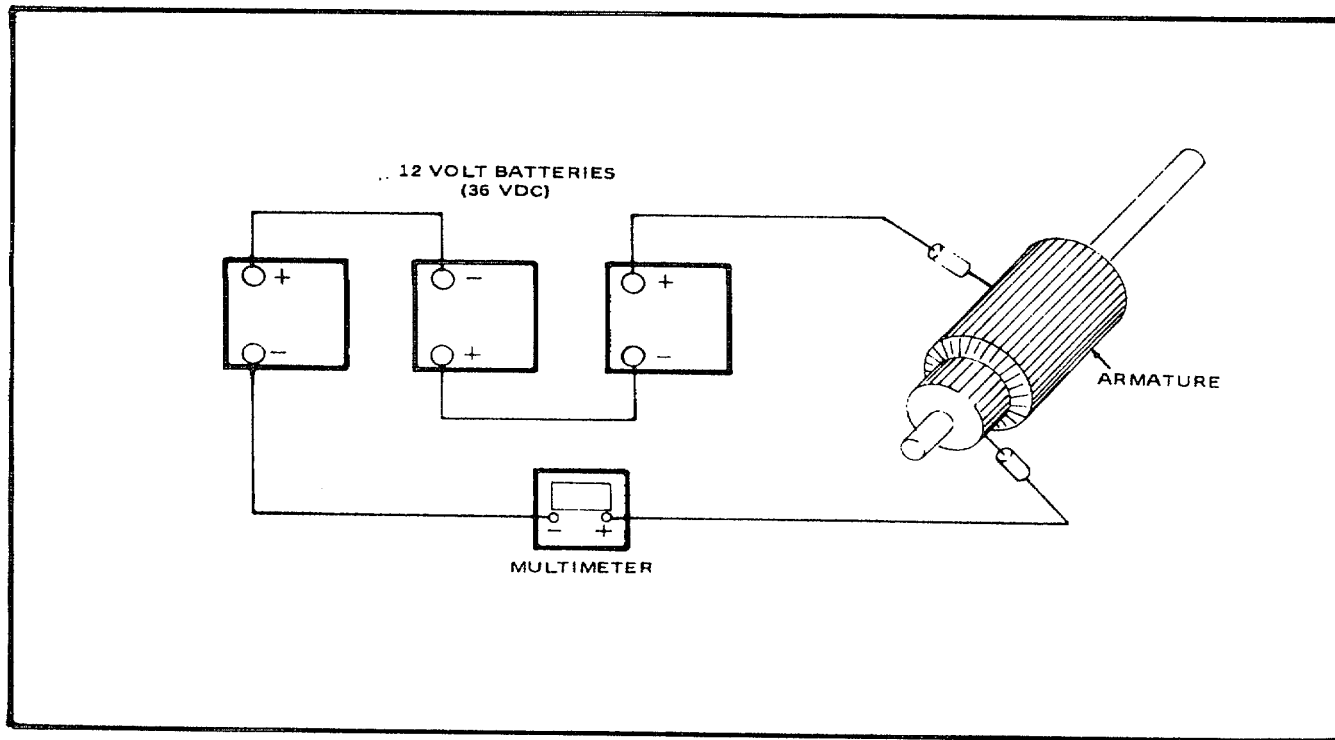

Figure 6-15. Grounded Armature test Setup

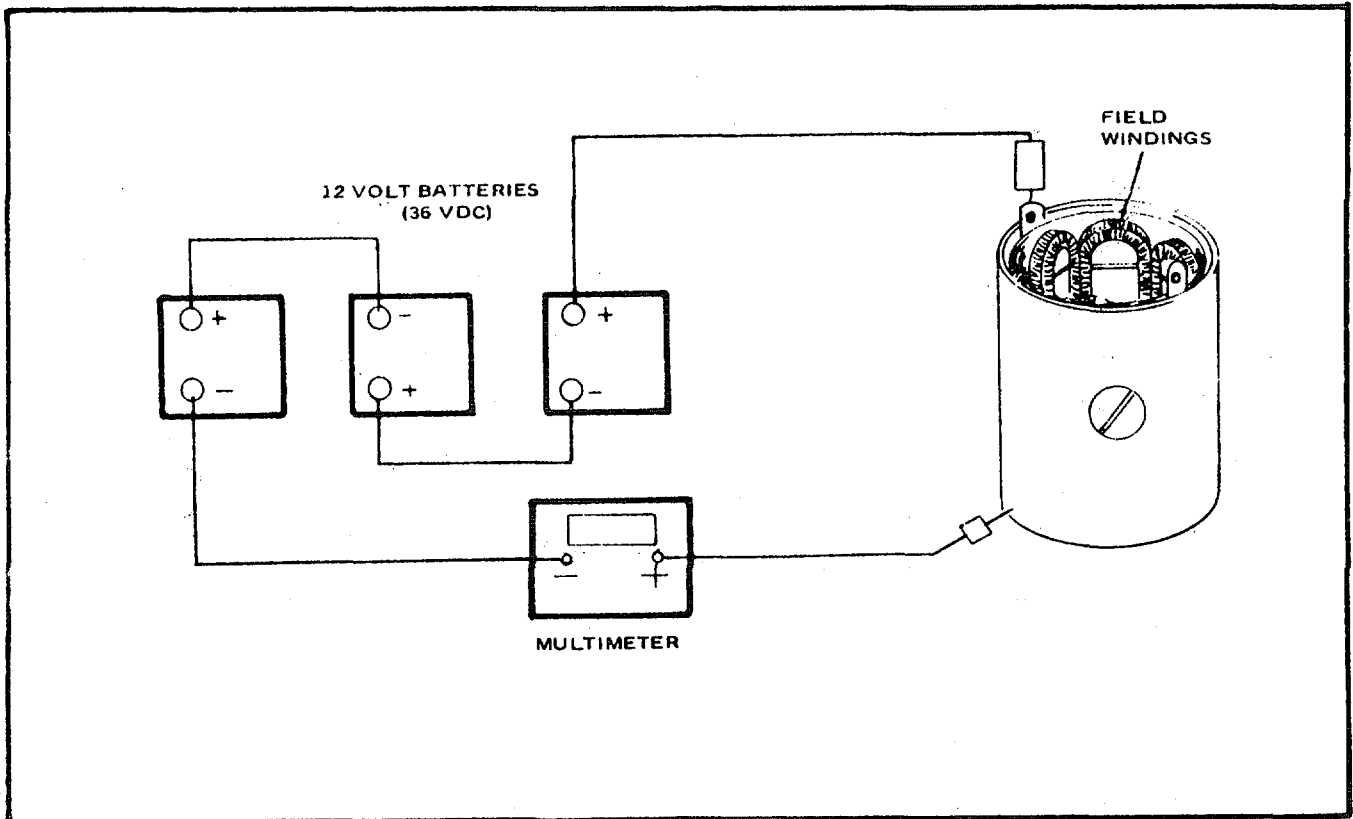

Figure 6-16. Field Winding Test Setup

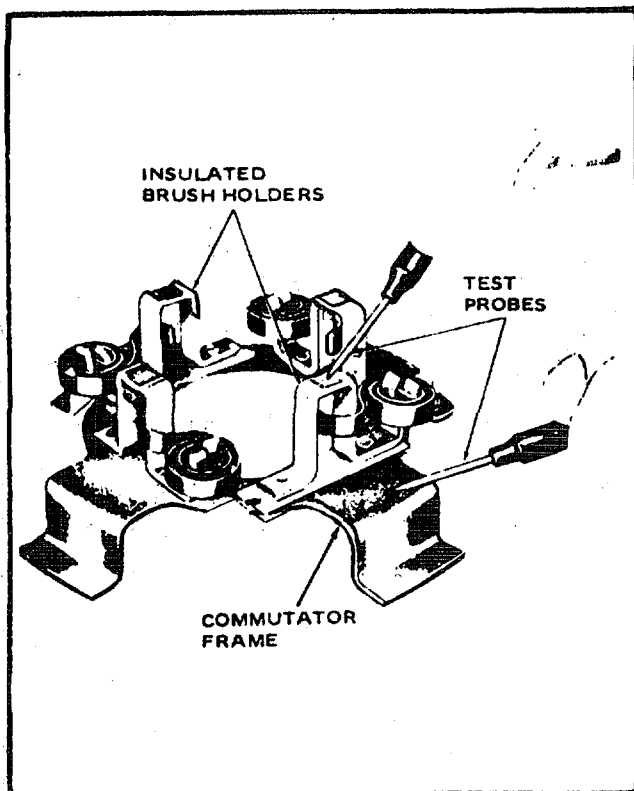

Figure 6-17. Testing Commutator Frame

Two of the holders directly opposite of each other are ground and should cause the multimeter to indicate zero ohms. The other two holders are insulated and the multimeter should indicate infinite resistance.

- (i) Should one or both of the insulated holders indicate zero ohms resistance, they are grounded and the commutator frame should be replaced.
- d. Repair or Replacement. Refer to paragraph 6-3.c for general repair or replacement instructions.
- (1) Replace burned or damaged field winding.
 - (2) Replace damaged or annealed bush springs.
 - (3) Replace pinion drive if clutch is damaged or the pinion teeth are worn.
 - (4) Replace worn or damaged fork lever,

e. Assembly. To assemble the starter motor assembly proceed as follows:

NOTE

Soak bearings (30, 28, 21 and 16) in oil, per Military Specification MIL-L-2104, or equivalent for at least one half hour before assembly.

- (1) Clamp armature (26) in a V-vise or equivalent. Coat threads on drive end of armature (26) with a thick coating of grease per Military Specification MIL-L 10294 or equivalent.
- (2) If replaced, press bearing (30) into bearing (29), slide bearing (29) over drive end shaft of armature (26). Press bearing (21) into pinion (20) and screw pinion (20) onto drive end shaft of armature (26). Slide bearing ring (11) onto armature (26) shaft and into pinion (20).
- (3) Fabricate a retaining ring expander tool as illustrated in figure 6-18. Slide snap ring (11) onto armature (26) shaft. Using expander tool, push snap ring (11) onto armature (24) shaft. See Figure 6-19.
- (4) Compress snap ring (11) into groove (30) and work the ring (11) into bearing (11). See Figure 6-20.

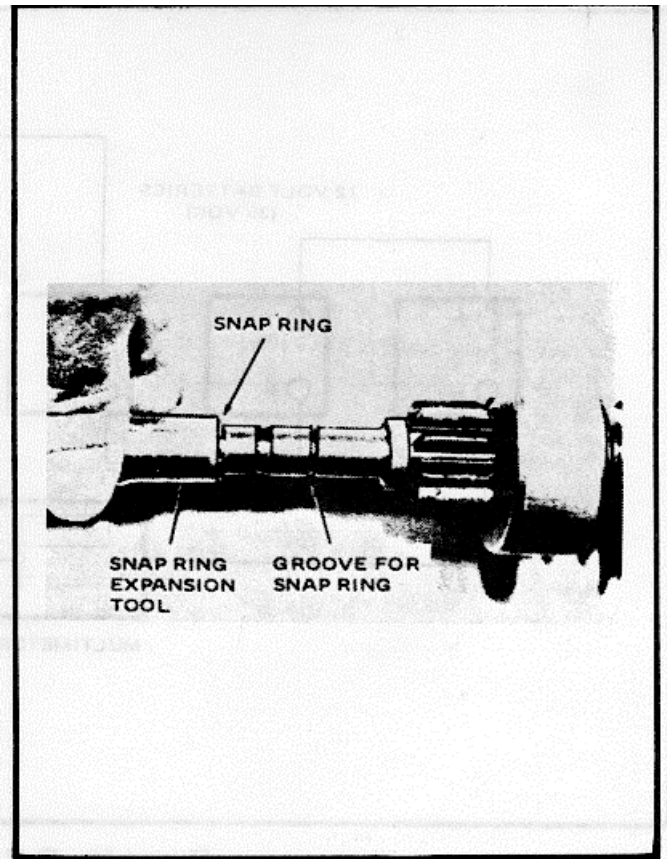

Figure 6-19. Assembling Snap Ring to Armature

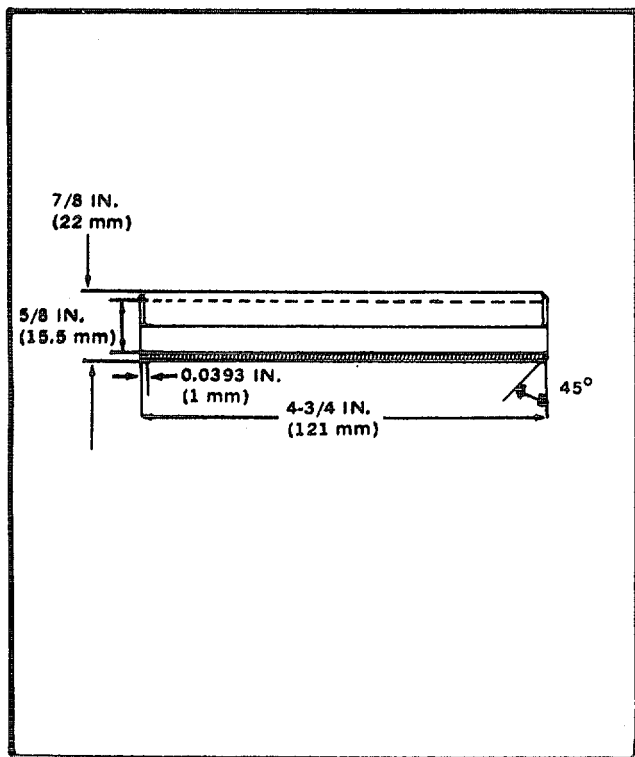

Figure 6-18. Snap Ring Expansion Tool

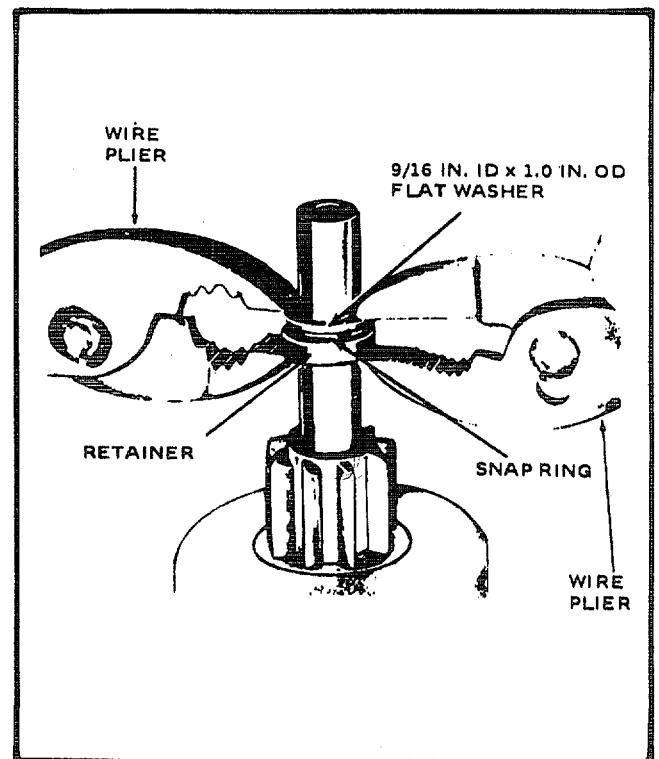

Figure 6-20. Assembling Snap Ring and Retainer

- (5) Insert lever (22) into frame (27). Slide the drive end of the armature (26) with attached pinion (20) into frame (27). Be sure that the studs on the lever (22) engage into the two-part guide ring on the pinion (20). Assemble screw (25) into frame (27) through the hole in lever (22), using washer (24) and nut (23). Attach bearing (29) to frame (27) using studs (13). Assure that marks on bearing (29) and frame (27) line up.
- (6) If insulated sleeves were on studs (13) at disassembly insert over studs (13) and carefully slide the housing (31) over studs (13). Slide brush holder (19) onto studs (13) and engage on housing (31). Attach brushes (18) to holder and insert springs (17) into brush holder frame (19).

NOTE

Check armature (26) axial play, play shall be 0.008 ± 0.004 inches (0.2 mm i 0.1 mm). If axial play is not as specified add or remove shims (11) until the desired results are obtained.

- (7) Place cover (12) over studs (13) and attach cover (1) using washer (15) and nuts (14). Re-place shim, washer, retainer ring and washer on end of armature (26) shaft. Using socket head screws (10) attach cap (9) on cover (12).
- (8) Attach solenoid (1) to frame (27) using screws (8). Attach field terminal lugs to solenoid (1) using washers (3 and 5) and nuts (2 and 4). If removed, -assemble clamp (7) with screw (6) to solenoid (1).

6-35. ALTERNATOR ASSEMBLY (See Figure 8-32). The following paragraphs contain disassembly, cleaning in-spection, repair or replacement and assembly instructions for the alternator assembly:

a. Disassembly. Disassemble the alternator assembly only to the extent necessary to repair or replace a defective part or parts.

- (1) Remove nut (1) and lockwasher (2) from rotor (13) shaft. If shieve (pulley) (14, Figure 8-30, Sheet 10 of 10) has not been removed, pull shieve (14), and remove key (3, Figure 8-32) from shaft.
- (2) Unscrew and remove screws (4), washers (5) and lockwashers (6).

- (3) Remove front housing (7) from rotor shaft. Re-move screws, washers and cover plate (8), and front end bearing (9) from front housing (7). Remove clip (10) and bearing from cover plate (8). If rear bearing (11) came and attached to rotor shaft (13) remove bearing. If bearing remained in housing the bearing (1) need not be removed unless it is to be replaced.

NOTE

Care should be taken when removing regulator (19) from housing shield (28) that springs (21) are not damaged or lost.

- (3) Remove collector ring (12) from rotor shaft (13). Remove stator (14) from end housing (28). Unscrew and remove screws and washer (15) and rectifier (16) from housing (28). Re-move screws (17), washers (18), and regulator (19) from the back of end housing (28). Re-move springs (21), brushes (20) and gasket (22).
- (4) Parts set B+ (23) and D+ (24) need not be re-moved unless replacement is required. Remove screw (25), washer (26) and diode assembly (27) from the back of housing shield (28).

b. Cleaning. Refer to paragraph 6-3.a for general clean-ing instructions.

CAUTION

Electrical components shall not be cleaned with dry cleaning solvents.

- (1) Wipe clean with dry lint face cloth or brush.
- (2) Clean metal parts using P-D-680, Type II dry cleaning solvent.
- (3) Allow parts to air dry.

c. Inspection. Refer to paragraph 6-3.b for general in-spection instructions.

d. Repair or Replacement. Refer to paragraph 6-3.c for general repair or replacement instructions.

- (1) Replace burned or damaged field winding.
- (2) Replace damaged or worn brushes or springs.
- (3) Replace worn or damaged bearings.

- (4) Replace damaged or burned wire and diode assemblies.

e. Assembly. To assemble the alternator assembly proceed as follows:

- (1) Assemble diode assembly (27) to housing shield (28) using washer (26) and screw (25). Assemble brushes (20) and springs (21) in regulator (19). Place washers (18) and screws (17) into regulator (19). Install gasket (22) over screws (17) and assemble regulator (19) to housing shield (28).
- (2) Install rectifier (16) into housing shield (28) and secure with screws and washers (15). Place collector ring (12), bearing (11) clip on rotor shaft (13). Install rotor shaft (13) into housing (28). Install stator (14) over rotor shaft (13) and into housing (28).
- (3) Install bearing (9) in front housing (7). Install cover plate (8) over bearing (9) using washers and screws. Insert cover plate bearing and secure with clip (10). Install front housing (7) over rotor shaft (13) and secure the front housing (7) to the rear housing (28) using washers (6 and 5) and screw (4). Place the spacer on the shaft, install key (3), pulley and fan and secure with washer (2) and nut (1).

6-36. Air Filter, Engine Oil Bath. (See Figure 8-33). The following paragraphs contain disassembly, cleaning, inspection, repair or replacement, and assembly instructions for the air filter assembly.

a. Disassembly. Disassemble the air filter assembly only to the extent necessary to repair or replace a defective part or parts.

- (1) Separate the oil container (1) halves by unlatching the latches. Remove external seal (2) and element assembly (3) from bottom half of oil container (1). Remove internal seal (4) from bottom half of oil container (1).
- (2) Remove rain cap (5) from top half of container (1) by loosening strap (6). Strap (6) need not be removed from rain cap (5).

b. Cleaning. Refer to paragraph 6-3.a for general cleaning instructions.

- (1) The filter (3) mesh material shall be reversed

out in clean diesel fuel and allowed to drip dry for at least thirty (30) minutes before installing.

c. Inspection. Refer to paragraph 6-3.b for general inspection instructions.

d. Repair or Replacement. Refer to paragraph 6-3.c for general repair or replacement instructions.

e. Assembly. To assemble the air filter assembly proceed as follows:

- (1) Attach rain cap (5) to top of oil container (1) using strap (6).
- (2) Install internal seal (4) into bottom half of oil container (1). Put new oil into bottom half of oil container (1) and install filter element assembly (3).
- (3) Install external seal (2) on bottom half of oil container (1).

CAUTION

Care should be taken when installing top half of oil container (1) over seal (2).

Install top half of oil container (1) over seal (2) and engage latches.

6-37. Fuel Feed Pump Assembly (See Figure 8-34). The following paragraphs contain disassembly, cleaning, inspection, repair or replacement and assembly instructions for the fuel feed pump assembly.

a. Disassembly. Disassemble the fuel feed pump assembly only to the extent necessary to repair or replace a defective part or parts.

- (1) Unscrew and remove screws and lockwashers (5) from pump body. Remove diaphragm (1) from feed pump base.

CAUTION

Use care in removing fuel filter (2). Filter (2) can be damaged if handled without care.

- (2) Remove screw and gasket (4) from top of feed pump. Remove the top cover, gasket (3) and fuel filter (2).

- b. Cleaning. Refer to paragraph 6-3.a for general clean-ing instructions.
 - (1) Clean fuel filter (2) using ultrasonic cleaner (Table 2-1).
- c. Inspection. Refer to paragraph 6-3.b for general in-spection instructions.
 - (1) Replace diaphragm (1) if deformed or cracked. (2) Replace filter (2) if rim or screen is cracked or broken.
- d. Repair or Replacement. Refer to paragraph 6-3.c for general repair or replacement instructions.
 - (1) Replace a deformed or cracked diaphragm (1).
 - (2) Replace fuel filter (2) if rim or screen is cracked or broken.
- e. Assembly. To assemble the fuel feed pump assem-bly, proceed as follows:
 - (1) Position fuel filter (2) on pump base. Place gasket (3) in top cover, and position top cover on base over fuel filter (2). Attach cover to base using gasket and screw (4).
 - (2) Insert diaphragm (1) into lower body and join both halves of the pump body using washer and screws (5).

6-38. Fuel Injection Pump Assembly (Figure 8-35). If fuel injection pump requires rework or repair, replace injection pump and send pump to be repaired to a Bosch Repair Center or equivalent. Time engine with new pump in accordance with DIESEL ENGINE ASSEMBLY, (Sec. VI, paragraph 6-33, e).

6-39. Fuel Injector Assembly (See Figure 8-36). The following paragraphs contain disassembly, cleaning, inspection, repair or replacement and assembly instructions for the fuel injector assembly.

- a. Disassembly. Only when test results are not within limits should the fuel injector assembly be disassembled. Disassemble the injector assembly only to the extent neces-sary to repair or replace a defective part or parts.

CAUTION

Under no circumstances should the nozzle, valves. and discs be interchanged. To avoid

interchanging, disassemble and reassemble one injector at a time.

CAUTION

Disassemble the fuel injector in a clean, well-lighted work area isolated from the rest of the shop.

- (1) Separate retainer nut (1) from nozzle holder (7).
- (2) Remove shim/s (2), pressure spring (3), and pressure spindle (4) from intermediate disc (5).
- (3) Separate disc (5) and nozzle (6).

- b. Cleaning. Refer to paragraph 6-3.a for general clean-ing instructions.

NOTE

Do not allow parts to remain in dry cleaning solvent for extended periods of time or rust spots may form. If parts are not to be inspected immediately after cleaning, dip them in engine oil per Military Specification MIL-- 2104 or equivalent.

- (1) All components shall be cleaned and washed out thoroughly in solvent. Federal Specification P-D-680, Type II.
- (2) Dry parts with low pressure compressed air (30 psig maximum).

NOTE

Do not be too hasty in judging the perform-ance of a nozzle. It has been found that after soaking nozzles in solvent for a day, that many will meet specifications for leakage or opening pressure that might otherwise be rejected.

- (3) After the nozzle (6) has soaked in solvent, use a brass wire brush to remove any remaining carbon or fuel stains from the tip. See Figure 6-21.
- (4) Clean the orifice holes in the nozzle valve body tip. Use a cleaning wire protruding only 1/16 inch (1.5875 mm) out of the pin vise for best

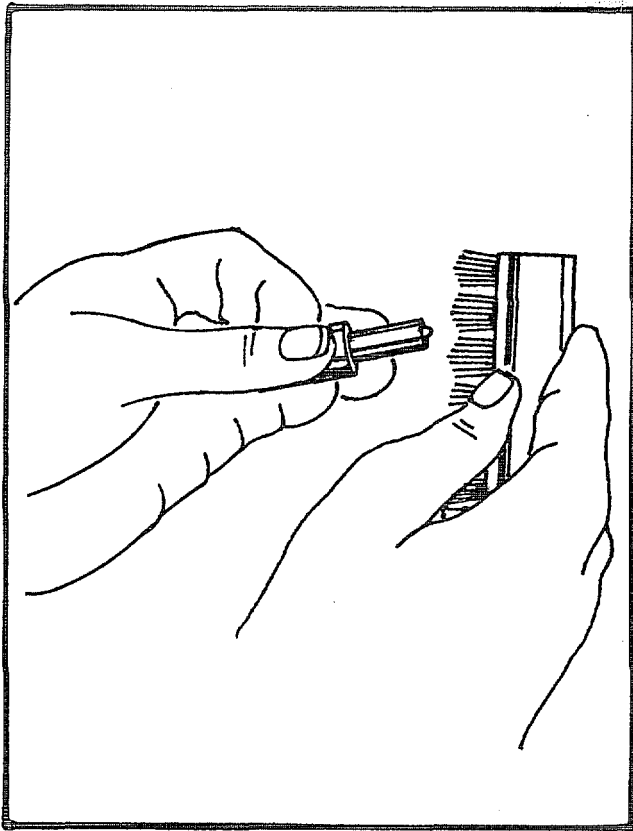

Figure 6-21. Cleaning the Nozzle Tip

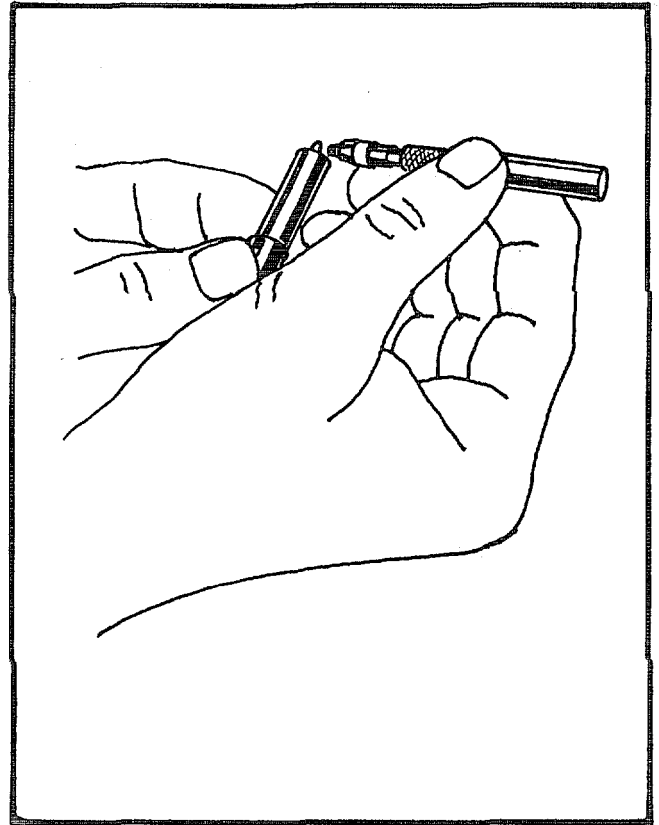

Figure 6-22. Cleaning the Orifice Holes

results, Start with a cleaning wire of .008 - .010 Inch (0.20 ± 0.003 mm) and .010 inch (.028 mm) for final cleaning. Clean the sac hole with a .051 Inch (1.3 mm) diameter drill. See Figure 6-22.

(5) Clean the valve seat area with a special brass scraper tool. Use cleaning tallow on the end of a 2.inch (50 mm) cleaning stick to polish the seat. Use a sac hole drill to push the tallow through the orifices. All openings must be open and clean, See Figure 6-23.

(6) Gum deposits may be removed with a brass wire brush, The upper portion (large diameter) of the valve should not be held between the finger, since damage from corrosion could re-suit, See Figure 6-24.

c. Refer to paragraph 6-3.b for general in-spection instructions.

(1) Using a magnifier, inspect the mating surfaces of the nozzle components, particularly the intermediate plate (5) and nozzle (6) for nicks, scratches or signs of corrosion. Failure of these

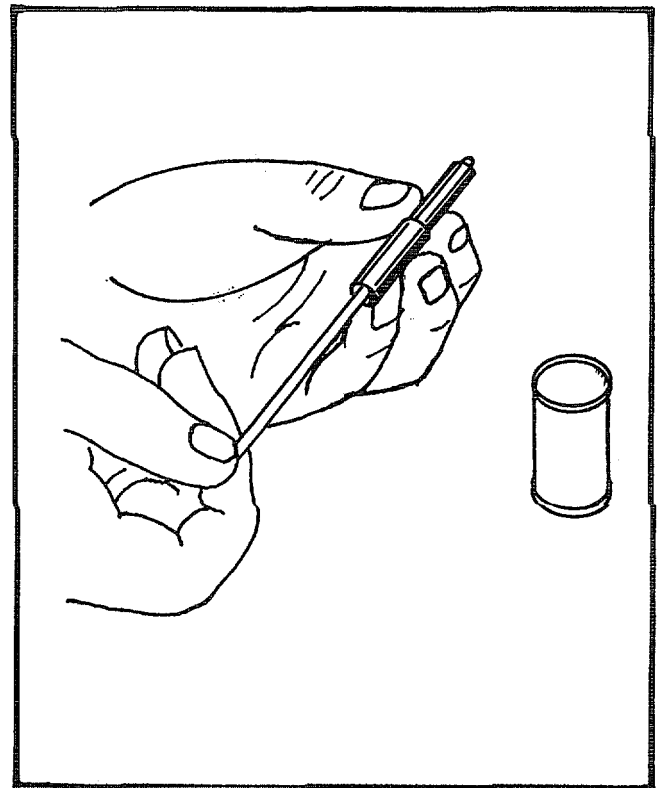

Figure 6-23. Cleaning Nozzle and Seat

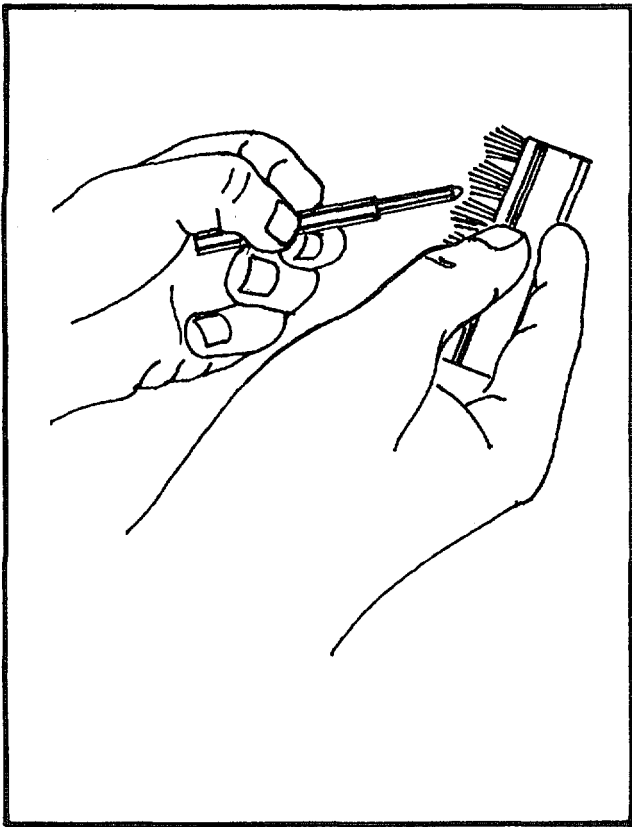

Figure 6-24. Cleaning Nozzle Valve

surfaces to seal properly will result in leakage to the return or to the outside of the nozzle. See Figure 6-25.

(2) Inspect the retainer nut (7) for cracks and re-place it if damaged.

(3) Check the stem and the body of the nozzle. When both parts are wet with fuel oil, no sticking should be evident. Pull the valve out of the nozzle about one-third of its length. When released, the valve should slide freely back to the seat. Foreign matter or scratches on the valve will cause it to stick. Carefully inspect before installing the valve. See Figure 6-26.

d. Repair or Replacement. Refer to paragraph 6-3.c for general repair or replacement instructions.

(1) If necessary, recondition nozzle and intermediate disc surfaces by lapping.

(2) Replace all threaded parts having worn, stripped or damaged threads.

c. Assembly. To assemble the fuel injector assembly, proceed as follows:

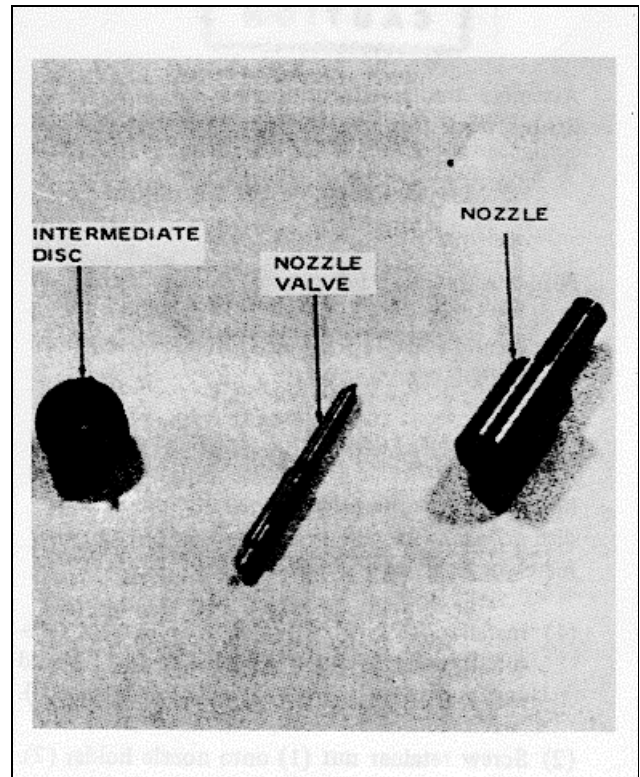

Figure 6-25. Inspecting Mating Surfaces

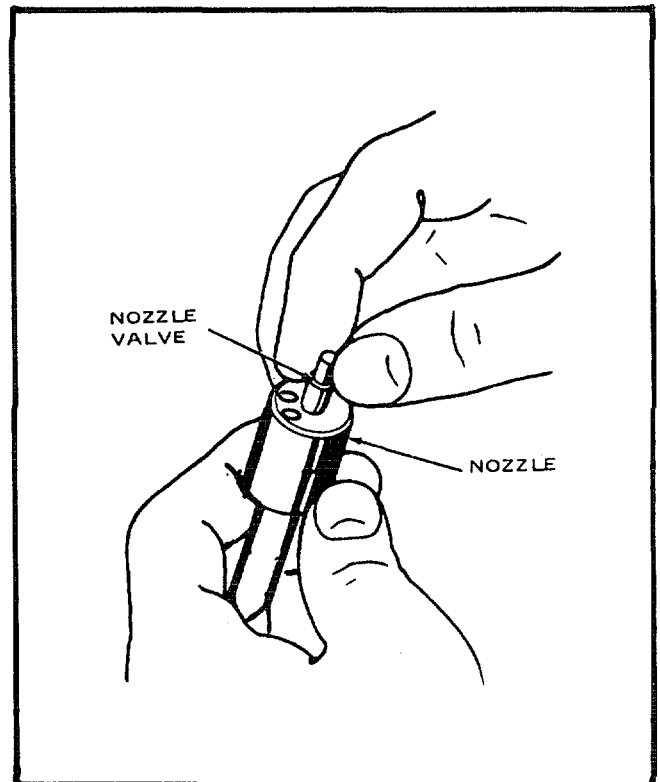

Figure 6-26. Checking Freedom of Valve in Nozzle

CAUTION

Assemble the fuel injector in a clean, well lighted work area isolated from the rest of the shop.

NOTE

Before assembling injector, all injector parts shall be dipped in engine fuel per Military Specification MIL-J-5624 or Federal Specification VV-F-800.

NOTE

Make sure that the guide pins on intermediate disc (5) bottom are inserted properly into matching holes on top of nozzle (6).

- (1) Install nozzle (6), intermediate disc (5), pressure spindle (4), and pressure spring (3) and appropriate number of shims (2) in holder (7).
- (2) Screw retainer nut (1) onto nozzle holder (7). Tighten nut (1) to 63 lbs ft (85 Nm) torque.
- (3) To test the fuel injector assembly, proceed as follows:

NOTE

Use clean filtered diesel fuel, per Military Specification MIL-J-5624 or Federal Specification VV-F-800, in nozzle tester.

- (a) Loosely connect injector to be tested to nozzle tester (Table 2-1) using test line listed in Table 2-1. Pump nozzle testers handle several times to flush air from test line. Tighten all connections.

WARNING

Keep hands away from nozzle spray. Spray can puncture the skin allowing test oil to enter the blood stream. Consult a physician at once if spray punctures the skin.

- (b) Close valve to bypass pressure gauge.
- (c) Pump nozzle testers handle up and down quickly (approximately six to eight times a

second). Fuel should spray from injector nozzle tip in an atomized mist (see Figure 6-27) and the nozzle should emit a sharp high-pitched chatter.

- (d) If nozzle does not chatter, flush nozzle by pumping tester handle rapidly. Repeat step c.
- (e) Pump the nozzle testers handle several times to flush air from the nozzle. Open pressure gauge valve. Slowly pump tester handle while observing pressure gauge. Nozzle should open at 2, 600 + 120 - 0 psig (17, 927 + 827- 00 KPa).

NOTE

Do not wipe the nozzle tip with the fingers as this will tend to draw the fuel present in the sac hole through the orifices and falsely indicate a leak and rejection of a good valve. Hold a wiper lightly against the tip of the valve.

- (f) Bleed off pressure until nozzle valve seats. Using a lint free cloth, wipe nozzle tip dry.

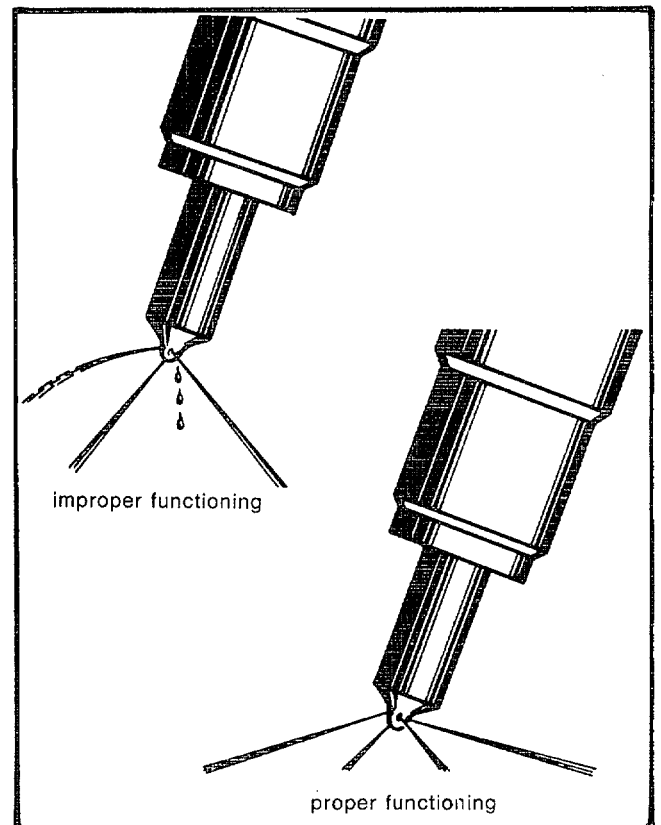

Figure 6-27. Fuel Injector Spray Pattern

Slowly pump pressure up to 2, 300 psig (15, 858 KPa) and maintain this pressure for ten seconds. Wetting of the nozzle is permissible without the formation of a droplet.

- (g) Bleed off pressure and remove injector from test line.
- (h) If injector failed to meet any of the preceding test results, refer to FUEL INJECTOR ASSEMBLY (Section VI) and repair injector.

6-40. Fuel Filter Assembly (See Figure 8-37). The following paragraphs contain disassembly, cleaning, inspection, repair or replacement, and assembly instructions for the fuel filter assembly.

a. Disassembly. Disassemble the fuel filter assembly only to the extent necessary to repair or replace a defective part or parts.

- (1) Unscrew and remove screw (1) and gasket (2). Separate filter housing (3) from filter flange (10).
- (2) Using o-ring, remove filter element (4) from housing (3).
- (3) Remove o-ring (5) from recess in flange (10).
- (4) Unscrew and remove bleed valve (6), gasket (7), pipe plug (8), and gasket (9) from flange (10).

b. Cleaning. Refer to paragraph 6-3.a for general cleaning instructions.

c. Inspection. Refer to paragraph 6-3.b for general inspection instructions.

- (1) O-ring for deformation, cuts, or nicks.
- (2) Housing for dents.
- (3) Flange for cracks or breaks.
- (4) Threaded parts (fittings, etc.) for stripped or damaged threads.

d. Repair or Replacement. Refer to paragraph 6-3.c for general repair or replacement instructions.

e. Assembly. To assemble the fuel filter assembly proceed as follows:

- (1) Assemble gasket (9), pipe plug (8), gasket (7), and bleed valve (6) to filter flange (10).
- (2) Coat o-ring (5) with engine fuel. Press o-ring (5) into recess in flange (10).
- (3) Wipe contact surfaces of filter element (4) with engine fuel. Install element (4) over stem in filter housing (3) with o-ring in down position.
- (4) Using copper gasket (2) and screw (1) attach housing (3) with element (4) to flange (10).

6-41. Frame Group (See Figure 8-38). The following paragraphs contain disassembly, cleaning, inspection, repair or replacement, and assembly instructions for the frame group.

a. Disassembly. Disassemble the frame group only to the extent necessary to repair or replace a defective part or parts.

- (1) If battery cables have not been removed from battery (3) remove cables.
- (2) Unscrew and remove wing nuts (1) from battery tie down. Remove battery retainer (2) and lift battery (3) from frame. Remove battery-support (4) and J-bolts (5) from engine supports (9).
- (3) Unscrew nuts (6), washers (7) and screws (8) from engine supports (9). Remove engine supports (9) from skid (17).
- (4) Unscrew and remove nuts (10), washers (11), straps (12) and webbing (13) from fuel tank (14). Remove fuel tank (14) from skid (17). If fuel tank is to be cleaned, remove plug (15) and cap (16) from fuel tank (14).

b. Cleaning. Refer to paragraph 6-3.a for general cleaning instructions.

c. Inspection. Refer to paragraph 6-3.b for general inspection instructions.

- (1) Check welds for cracks or tears.
- (2) Check fuel tank for seam tears or cracks.

d. Repair or Replacement. Refer to paragraph 6-3.c for general repair or replacement instructions.

- (1) Weld any cracks in frame.
- (2) Replace fuel tank if seams are split or there are cracks.

e. Assembly. To assemble the frame group proceed as follows:

- (1) Install cup (16) and drain plug (15) on fuel tank (14).
- (2) Install fuel tank (14) in frame (17). Place webbing (13) and straps (12) in place, and install washers (11) and nuts (10) on straps (12).
- (3) Position engine supports (9) on frame (17) and secure using screws (8), washers (7) and nuts (6). Position battery support (4) between engine supports (9), install J-bolts (5), battery (3), battery retainer (2) and wing nuts (1). In-install battery cables after engine has been installed.

6-42. TABLE OF LIMITS. The minimum and maximum limits in the following Table of Limits represent ideal limits. Measurements not exceeding the replacement maximum permits the part to be retained in service. Parts for which tolerances are given are not necessarily reusable if they are otherwise worn or damaged, although their dimensions may be within these specified.

6-43. Refer to Table 6-1 for wear limits, end play, clearances, and backlash, as applicable. Refer to Table 6-2 for spring data and specific torque limits.

6-44. TEST. The following paragraph contains all the necessary operating instructions and tests to be performed after repair of the air compressor unit to ensure satisfactory operation. To perform the tests, proceed as follows:

NOTE

Refer to LUBRICATION INSTRUCTIONS (Section V) and make certain air compressor unit is properly lubricated. To perform the tests, proceed as follows:

- a. Make certain CLUTCH operating rod (11, Figure 4-2) is in disengaged position, away from control panel.
- b. Make certain COMPRESSOR UNLOADER switch (16, Figure 4-2) is in the UNLOAD position and close all control panel valves.
- c. Make certain ENGINE THROTTLE CONTROL (10, Figure 4-2) is positioned half way in (idle position, 1, 000 + 100 rpm [1, 100 + 100 r/min]).
- d. Turn MASTER SWITCH (9, Figure 4-2) to 450 cw position.

CAUTION

If engine oil pressure does not register on gauge within five seconds, immediately shut down engine and determine cause. Refer to TROUBLESHOOTING (Section V).

- e. Push engine START switch (8, Figure 4-2). When engine starts continue to hold START switch until ENGINE OIL PRESSURE gauge (6, Figure 4-2) registers pressure; then, release START switch.

CAUTION

If compressor oil pressure does not register within 5 seconds, shut down engine, and determine cause. Refer to TROUBLESHOOTING, (Section V).

Table 6-1. Table of Limits

REF NO.	CHART NO. (FIGURE)	DESCRIPTION	MINIMUM INCHES (MILLIMETERS)	MAXIMUM INCHES (MILLIMETERS)	REPLACE-MENT MAX
1	6-29	CONTINUOUS BLEED VALVE SUBASSEMBLY Orifice Screw Orifice diameter	0.030 (0.7620)	0.033 (0.7620)	0.035 (0.0889)

Table 6-1. Table of Limits- Continued

REF NO.	CHART NO. (FIGURE)	DESCRIPTION	MINIMUM INCHES (MILLIMETERS)	MAXIMUM INCHES (MILLIMETERS)	REPLACE- MENT MAX
2	6-29	CONTINUOUS BLEED VALVE SUBASSEMBLY - Continued Valve Plunger Plunger tip diameter	0.062 (1.5748)	0.067 (1.7018)	
3	6-29	Plunger body diameter	0.1855 (4.7062)	0.1872 (4.7548)	
2, 3	6-29	Tip to body concentricity.....			0.001 TI R (0.0254TIR)
4	6-29	Valve Seat Inside diameter (for plunger tip)	0.0937 (2.3800)	0.0950 (2.4130)	
5	6-29	Plunger body bore diameter	0.189 (4.8006)	0.190 (4.8260)	
4, 5	6-29	Bore concentricity			0.0025TIR (0.063 5TI R)
6	6-29	Bleed Valve Outside diameter	0.161 (4.0894)	0.164 (4.1656)	
7	6-29	Tip diameter.....	0.063 (1.6002)	0.073 (1.8542)	
6, 7	6-29	OD to tip concentricity.....			0.001T1R (0.0254TIR)
		AIR COMPRESSOR ASSEMBLY			
1	6-30	Oil Seal Cover Outside diameter	4.995 (126.873)	4.998 (126.949)	
2	6-30	O-ring seal diameter	4.770 (121.158)	4.780 (121.412)	
3	6-30	Seal register inside diameter	1.998 (50.749)	2.002 (50.851)	
4	6-30	Face of flange to depth of seal register bore	1.432 (36.373)	1.442 (36.627)	
5	6-30	Flange mounting face flat within....			0.002 (0.051)
1	6-31	Outer Oil Pump Cover Outside diameter	4.993 (126.822)	4.998 (126.949)	
2	6-31	Face of cover flat and parallel with.....			0.002 (0.0508)

Table 6-1. Table of Limits - Continued

REF NO.	CHART NO. (FIGURE)	DESCRIPTION	MINIMUM INCHES (MILLIMETERS)	MAXIMUM INCHES (MILLIMETERS)	REPLACE- MENT MAX
		AIR COMPRESSOR ASSEMBLY- Continued			
1	6-32	Non Drive-End Cover Oil relief valve piston OD	0.3750 (9.525)	0.3752 (9.530)	
2	6-32	Oil relief valve bushing bore	0.380 (9.652)	0.382 (9.703)	
3	6-32	Oil relief valve bushing OD	0.501 (12.725)	0.502 (12.751)	
4	6-32	Bushing length	0.435 (11.049)	0.440 (11.176)	
2, 3	6-32	Bushing ID concentric with OD.....			0.002TIR (0.0508TIR)
		Bushing faces parallel			0.005TIR (0.127TIR)
0.005TIR		Bushing faces perpendicular to OD			(0.127TIR)
5	6-32	Flange register diameter.....	8.248 (209.4992)	8.249 (209.5246)	
6	6-32	Bearing bore diameter	4.7242 (119.9947)	4.7252 (120.0201)	
7	6-32	Oil seal cover bore diameter	5.000 (127.0000)	5.002 (127.0508)	
8	6-32	Oil pump bore diameter	3.375 (85.7250)	3.376 (85.7504)	
9	6-32	Oil pump rotor bore eccentric to horizontal centerline	0.094 (2.3876)	0.095 (2.4130)	
5, 6	6-32	Flange register diameter concentric with bearing bore			0.002TIR (0.0508TIR)
10	6-32	Depth of bearing bore below mounting flange faced surface	0.436 (11.0744)	0.438 (11.1252)	

Table 6-1. Table of Limits - Continued

REF NO.	CHART NO. (FIGURE)	DESCRIPTION	MINIMUM INCHES (MILLIMETERS)	MAXIMUM INCHES (MILLIMETERS)	REPLACE- MENT MAX
		AIR COMPRESSOR ASSEMBLY - Continued			
11	6-32	Width of oil pump rotor surface bore.....	0.625 (15.8750)	0.626 (15.9004)	
1	6-33	Oil Pump Rotor Bore diameter	1.500 (38.1000)	1.501 (38.1254)	
2	6-33	Outside diameter	3.182 (80.8228)	3.183 (80.8482)	
2, 1	6-33	OD concentric with ID			0.002TIR (0.0508TIR)
3	6-33	Blade slot width	0.499 (12.6746)	0.500 (12.7000)	
4	6-33	Blade slot root from center	1.073 (27.2542)	1.083 (27.5082)	
5	6-33	Blade slots root-to-root	2.146 (54.5084)	2.166 (55.0164)	
6	6-33	Rotor thickness.....	0.623 (15.8242)	0.624 (15.8496)	
7	6-33	Rotor faces flat and parallel.....			0.002T11R (0.0508TI R)
1	6-34	Oil Pump Blade Diameter	0.497 (12.6238)	0.498 (12.6492)	
2	6-34	Length.....	0.623 (15.8242)	0.624 (15.8496)	
3	6-34	Ends flat and parallel			0.01TIR (0.0254TI R)
1	6-35	Oil Pump Inner Cover Outside diameter	4.715 (119.7610)	4.720 (119.8880)	
2	6-35	Oil seal bore	2.250 (57.1500)	2.252 (57.2008)	

Table 6-1. Table of Limits - Continued

REF NO.	CHART NO. (FIGURE)	DESCRIPTION	MINIMUM INCHES (MILLIMETERS)	MAXIMUM INCHES (MILLIMETERS)	REPLACE- MENT MAX
		AIR COMPRESSOR ASSEMBLY - Continued			
3	6-35	Cover thickness	0.498 (12.6492)	0.499 (12.6746)	
4	6-35	Faces of cover flat and parallel.			0.002TIR (0.0508TIR)
		Drive End Cover			
1	6-36	Crankcase register diameter ...	8.248 (209.4992)	8.249 (209.5246)	
2	6-36	Bearing bore	4.7242 (119.9947)	4.7252 (120.0201)	
3	6-36	Bearing bore depth above mounting face surface	0.070 (1.7780)	0.072 (1.8288)	
4	6-36	Oil seal bore	3.499 (88.8746)	3.502 (88.9508)	
5	6-36	Clutch housing register diameter		10.245 (260.2992)	10.248
		Crankcase register and bores for bearing and oil seal concentric within			0.002TIR (0.0508TIR)
		Flywheel			
1	6-37	Crankshaft bore	2.166 (55.0164)	2.167 (55.0418)	
2	6-37	Oil seal register diameter	2.749 (69.8246)	2.751 (69.8754)	
1, 2	6-37	Crankshaft bore to oil seal diameter concentric within			0.002TIR (0.0508TIR)
		Connecting Rods			
1	6-38	Crankshaft bearing bore	3.7518 (95.2957)	3.7557 (95.3948)	
2	6-38	Width, crankshaft end	0.870 (22.0980)	0.875 (22.2250)	

Table 6-1. Table of Limits Continued

REF NO.	CHART NO. (FIGURE)	DESCRIPTION	MINIMUM INCHES (MILLIMETERS)	MAXIMUM INCHES (MILLIMETERS)	REPLACE- MENT MAX
		AIR COMPRESSOR ASSEMBLY - Continued			
3	6-38	Crank to pin center	5.124 (130.1495)	5.126 (130.204)	
4	6-38	Piston pin bearing width, 2nd, 3rd, and 4th stage	0.990 (25.1460)	1.000 (25.4000)	
5	6-38	Piston pin rod end with, 1st stage	(19.3040)	0.760 (19.4310)	0.765
6	6-38	Piston pin bore, 1st stage	1.0005 (25.4127)	1.0008 (25.4203)	
		Crankshaft			
1	6-39	Connecting rod bearing journal	3.746 (95.1484)	3.747 (95.1738)	
2	6-39	End bearing journals.....	2.1653 (54.9986)	2.1659 (55.0139)	
3	6-39	Oil pump journal	1.499 (38.0746)	1.500 (38.1000)	
4	6-39	Oil seal journal	1.374 (34.8996)	1.375 (34.9250)	
2, 3	6-39	End bearing journals and oil pump journal concentricity			0.005TIR
		Piston and Pin Subassy, 1st Stage			
1	6-40	Piston pin diameter	0.9998 (25.39492)	1.0000 (25.40000)	0.9988 (0.2489)
2	6-40	Piston pin bore diameter	0.9998 (25.39492)	1.0002 (25.40508)	1.0018 (25.44572)
3	6-40	Cylinder Bore Diameter, 1st Stage	5.000 (127.0000)	5.002 (127.0508)	
		Piston and Pin Subassy, 2nd Stage			
1	6-41	Piston pin diameter.....	1.0000 (25.4000)	1.0003 (25.40762)	0.9990 (25.3746)
2	6-41	Piston pin bore diameter	1.0001 (25.40254)	1.0005 (25.4127)	1.0015 (25.4381)

Table 6-1. Table of Limits- Continued

REF NO.	CHART NO. (FIGURE)	DESCRIPTION	MINIMUM INCHES (MILLIMETERS)	MAXIMUM INCHES (MILLIMETERS)	REPLACE- MENT MAX
		AIR COMPRESSOR ASSEMBLY - Continued			
3	6-41	Cylinder ring bore diameter, 2nd stage	2.500 (63.5000)	2.501 (63.5254)	2.502 (63.5508)
1	6-42	Piston and Pin Subassy, 3rd Stage Piston pin diameter	1.000 (25.4000)	1.0003 (25.40762)	0.9990 (25.3746)
3	6-42	Cylinder ring bore diameter, 3rd stage	1.437 (36.4998)	1.438 (36.5252)	1.439 (36.5506)
1	6-43	Cylinder Liner, 4th Stage Bore diameter	0.750 (19.0500)	0.751 (19.0754)	0.752 (19.108)
1, 2	6-43	Out-of-round not to exceed			0.50005TIR (0.0127TIR)
1	6-44	Piston pin, 4th stage, OD	1.0000 (25.4000)	1.0003 (25.40762)	0.9990 (25.3746)
2	6-44	Piston pin bore diameter	1.0001 (25.40254)	1.0005 (25.4127)	1.0015 (25.4381)
4	6-44	Piston neck extension diameter	0.405 (10.2870)	0.410 (10.4140)	
5	6-44	Piston skirt outside diameter	2.246 (57.0484)	2.247 (57.0738)	
7	6-44	Ring mounting diameter	0.374 (9.4996)	0.375 (9.5250)	
		DRAIN VALVE ASSEMBLY			
1	6-45	Piston Bore	0.250	0.251	
2	6-45	Outside diameter	1.739 (44.1706)	1.743 (44.2722)	
3	6-45	Root of o-ring groove diameter.	1.504 (38.2016)	1.508 (38.3032)	
		OD and groove diameter concentric with bore within			0.002TIR (0.05081 R)

Table 6-1. Table of Limits Continued

REF NO.	CHART NO. (FIGURE)	DESCRIPTION	MINIMUM INCHES (MILLIMETERS)	MAXIMUM INCHES (MILLIMETERS)	REPLACE- MENT MAX
		DRAIN VALVE ASSEMBLY - Continued			
4	6-45	Piston faces perpendicular to bore			0.002TIR (0.0508TIR)
5	6-45	Seat Shoulder diameter	0.500 (12.7000)	0.503 (12.7762)	
6	6-45	Valve Stem Piston mounting journal (thread end)	0.248 (6.2992)	0.249 (6.3246)	
7	6-45	O-ring groove diameter	0.187 (4.7498)	0.189 (4.8006)	
8	6-45	Stem guide journal	0.310 (7.8740)	0.311 (7.8994)	
		Above three surfaces concentric within			0.002TI R (0.0508TIR)
9	6-45	Valve Body Stem register bore	0.313 (7.9502)	0.314 (7.9756)	
10	6-45	Seat register bore	0.500 (12.7000)	0.501 (12.7254)	
11	6-45	Piston bore	1.750 (44.4500)	1.752 (44.5008)	

Table 6-2. Miscellaneous Table

REF NO.	FIG. OR CHART NO.	DESCRIPTION	SPRING DATA					
			TEST FORCE		LG UNDERFREE TEST IN. (MM)	LENGTH IN. (MM)	ACTIVE COILS	OUTSIDE DIA IN. (MM)
			MIN	MAX				
5	Figure 8-5	Priority Valve Assembly Valve Spring	N/A	N/A		1.125 (28.5750)	6	0.700 (17.7800)
4	Figure 8-26	Continuous Bleed Valve Subassembly 1st, 2nd stage, accum. Valve spring	N/A	N/A		2 (50.8000)	10	0.947 (24.0538)
4	Figure 8-26	Continuous Bleed Valve Subassembly 3rd stage valve spring	N/A	N/A		2.750 (69.8500)	10	0.947 (24.0538)
42	Figure 8-12	Air Compressor Assembly Oil relief spring	N/A	N/A		1.250 (31.7500)	10	0.380 (9.6520)
42	Figure 8-30 (sheet 7 of 10)	Diesel Engine Assembly External valve spring	307 psi (44.5 kPA)	N/A	1.55 (39.5000)	2.284 (58.0000)	6.9	1.270 (32.2500)
43	Figure 8-30 (sheet 7 of 10)	Internal valve spring	N/A	N/A		0.787 (20.0000)	4.7	0.571 (14.5000)
11	Figure 8-27	Drain valve Assembly Valve spring	N/A	N/A		2.500 (63.5000)	5	1.427 (36.2458)
AIR COMPRESSOR UNIT TORQUE LIMITS								
							TORQUE VALUE LB-FT (Nm)	
DESCRIPTION								
2	Figure 8-26	Continuous Bleed Valve Subassembly, cap to body cap screws					16± 1 lb-in. (1.8 ±0.1 Nm)	
6	Figure 8-14	First Stage Cylinder Hd. Cap Screws					20 lb-ft (27 Nm)	
6	Figure 8-15	Second Stage Cylinder Head, cap screws					25 lb-ft (34 Nm)	
5	Figure 8-16	Third Stage Cylinder Head, cap screws					45 lb-ft (61 Nm)	
2	Figure 8-17	Fourth Stage Cylinder head, cap screws					45 lb-ft (61 Nm)	
25	Figure 8-19	Clutch to engine crankshaft retaining bolt					20 lb-ft (27 Nm) - with 3 to 4 drops of red Loctite (No 277)	

f. With air compressor unit operating pull ENGINE THROTTLE CONTROL to the full out position and lock in place.

g. Push ENGINE THROTTLE CONTROL completely in to stop.

h. If engine does not stop, loosen wire stop (13, Figure 8-30) and adjust throttle lever until engine stops. Without disturbing setting of throttle lever, tighten wire stop (13).

i. Repeat steps a through e. Pull engine THROTTLE CONTROL to the full out position and lock by turning handle in clockwise direction. The engine should operate at 2150 ± 50 rpm (2150 + 50 r/min).

WARNING

Make certain all control valves on control panel are closed.

j. Engage clutch by pushing CLUTCH operating rod towards panel. Place COMPRESSOR UNLOADER switch to LOAD position to pressurize receiver.

k. Observe Service Pressure gauge (4, Figure 4-2) indication. With air compressor unit operating under normal conditions, the compressor unit should unload at a maximum pressure of 3400 psig (23, 426 kPa). The air compressor unit should load at a minimum pressure of 3100 psig (21, 359 kPa). If air compressor loads or unloads at an in-correct pressure, refer to TROUBLESHOOTING (Section V).

l. Open the SERVICE HOSE BLEED valve, MECHANICAL FILTER DRAIN valve and DEHYDRATOR BLEED VALVE. Observe the COMPRESSOR OUTPUT and SERVICE PRESSURE pressure gauges.

m. Place the COMPRESSOR UNLOADER SWITCH (16, Figure 4-2) to the UNLOAD position.

n. Disengage clutch by pulling CLUTCH operating rod away from control panel. Push ENGINE THROTTLE CONTROL in to the idle position.

o. Allow engine to run without a load at idle speed for approximately five (5) minutes.

p. Push ENGINE THROTTLE CONTROL completely in. Turn MASTER SWITCH 450 ccw.

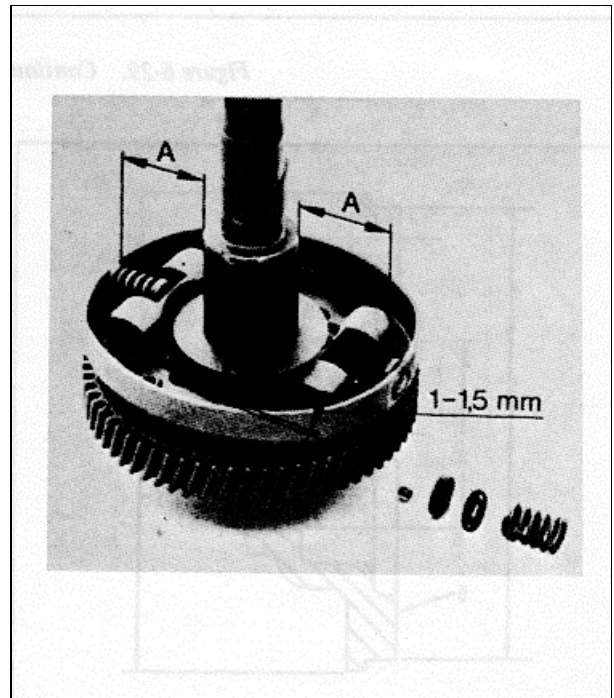

Figure 6-28. Spring Plate to Camshaft Adjustment.

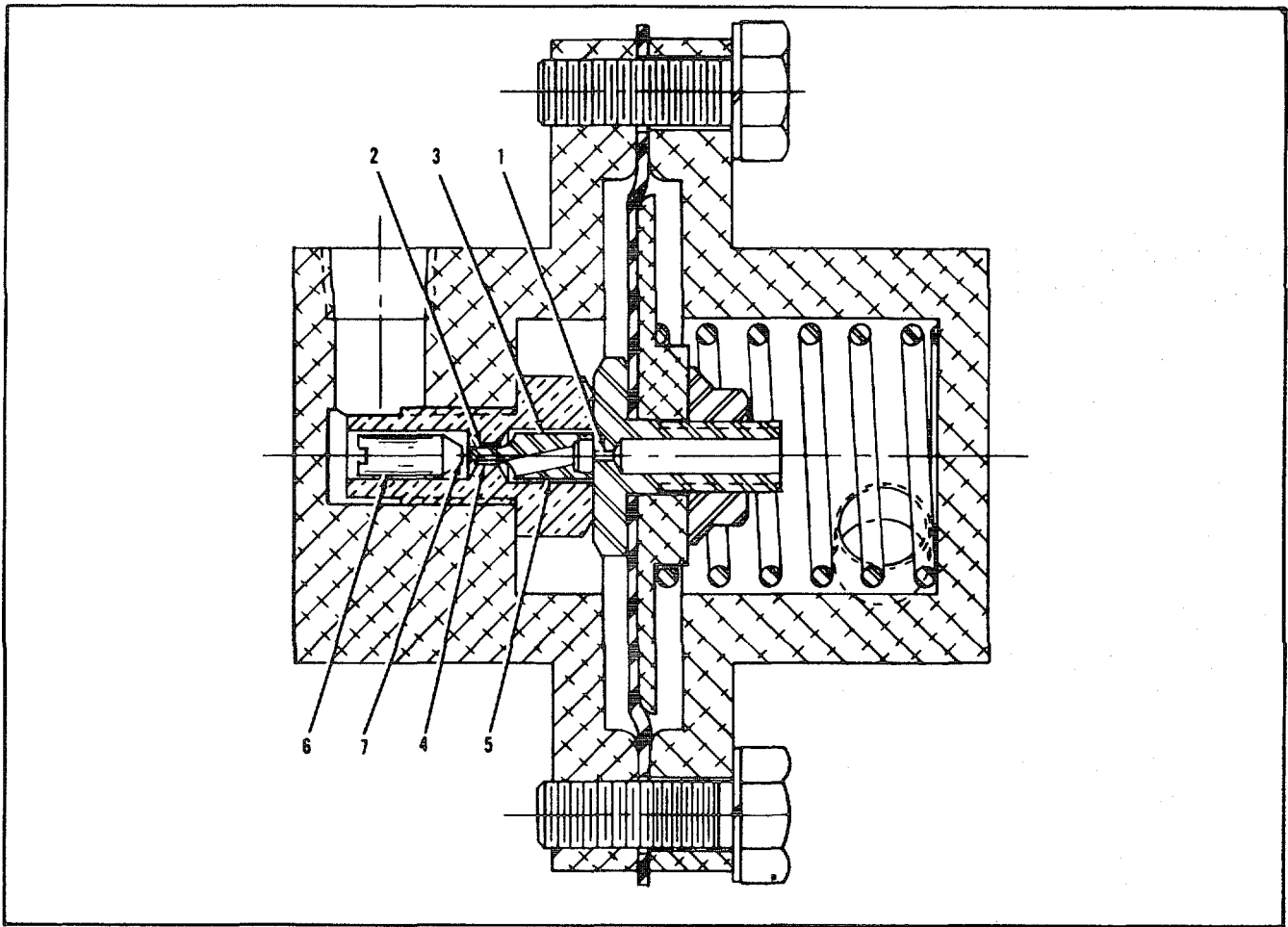

Figure 6-29. Continuous Bleed Valve Assembly

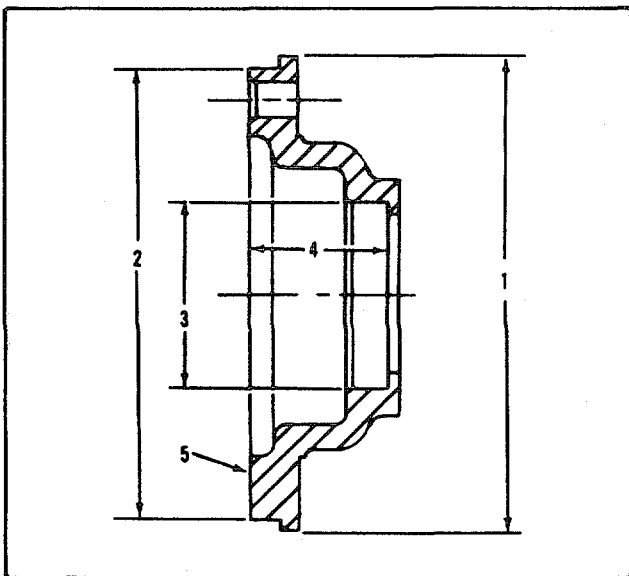

Figure 6-30. Compressor Oil Seal Cover

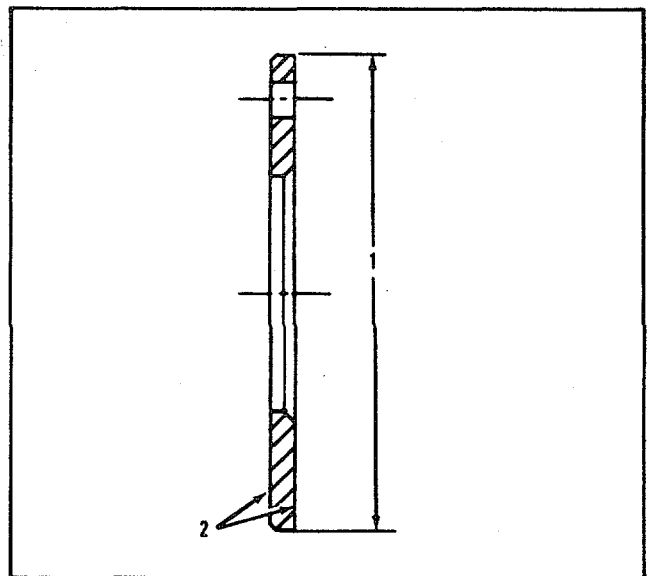

Figure 6-31. Outer Oil Pump Cover

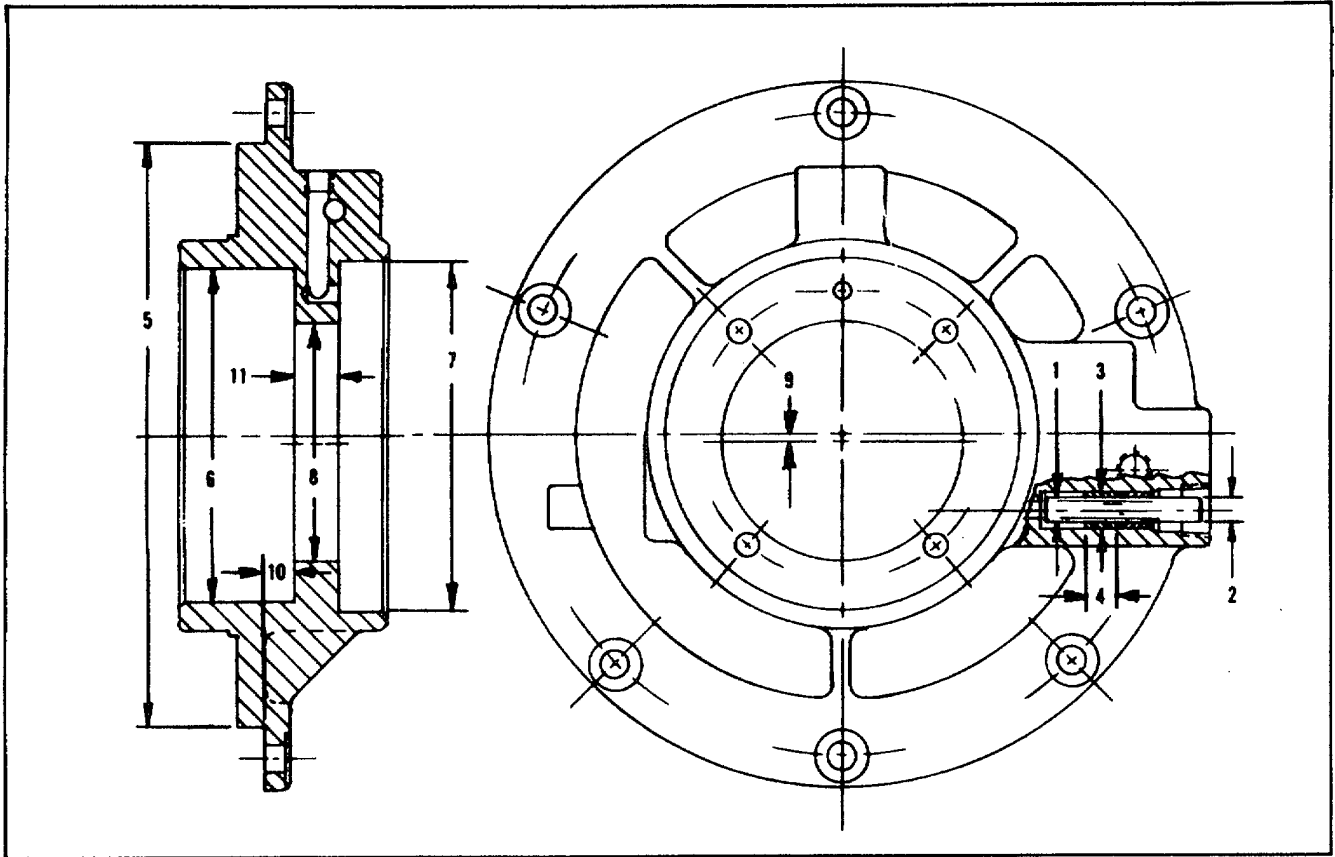

Figure 6-32. Non Drive End Cover

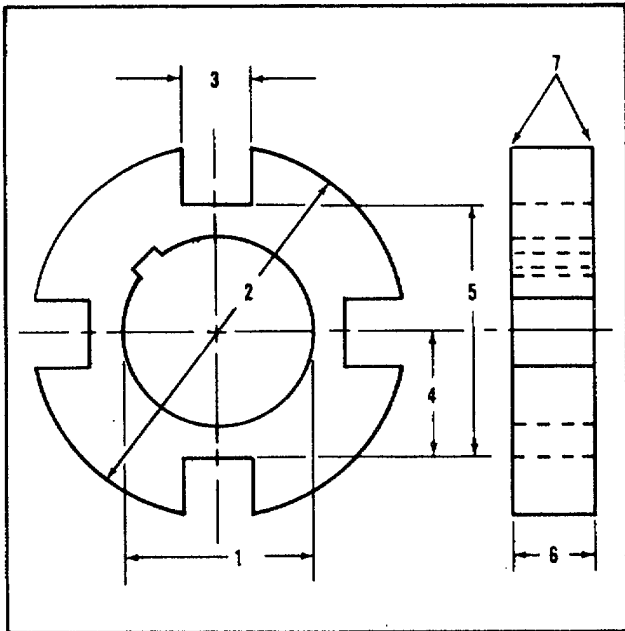

Figure 6-33. Oil Pump Rotor

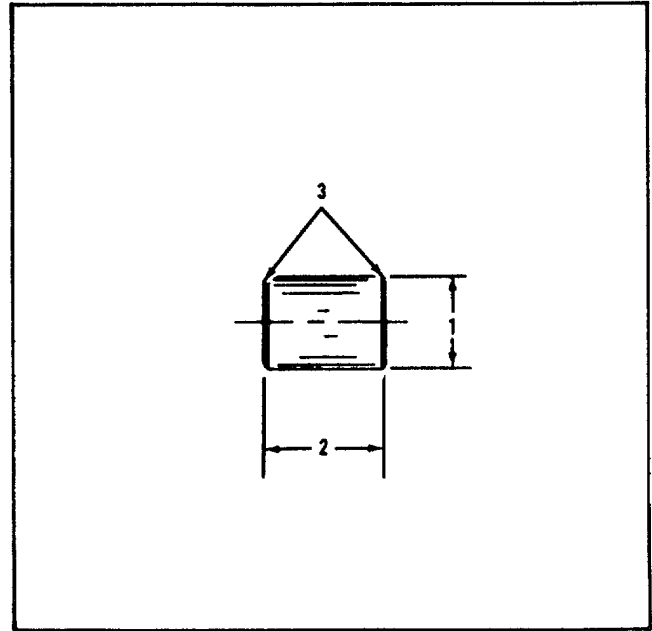

Figure 6-34. Oil Pump Blade

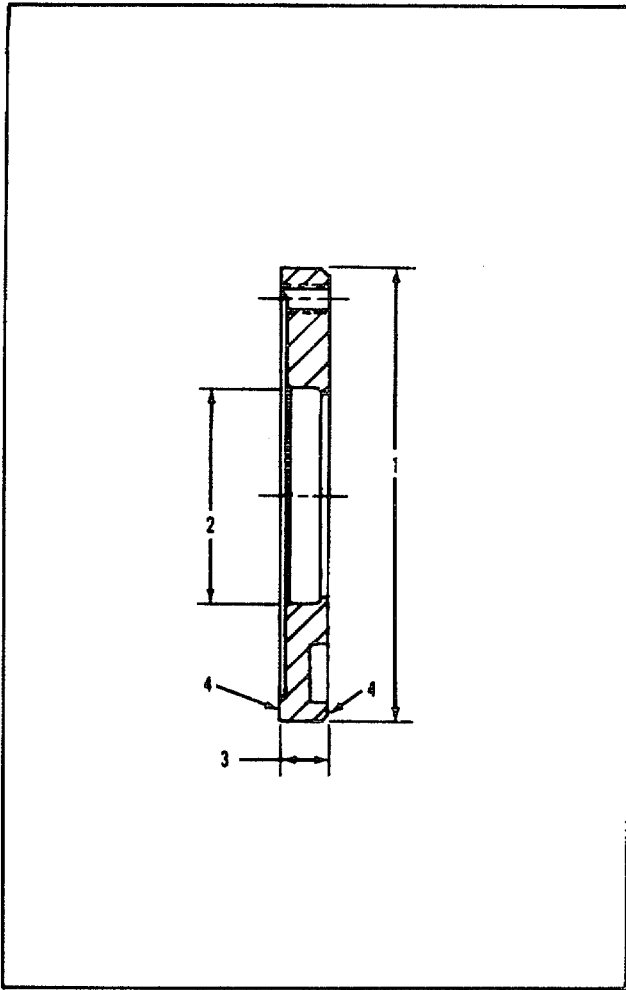

Figure 6-35. Oil Pump Inner Cover

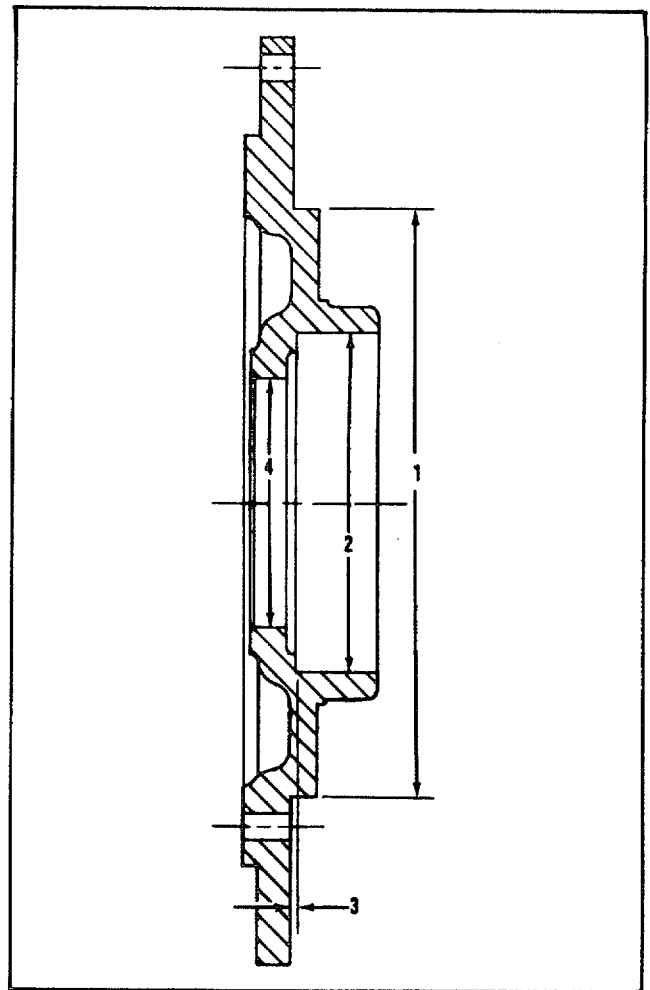

Figure 6-36. Drive End Cover

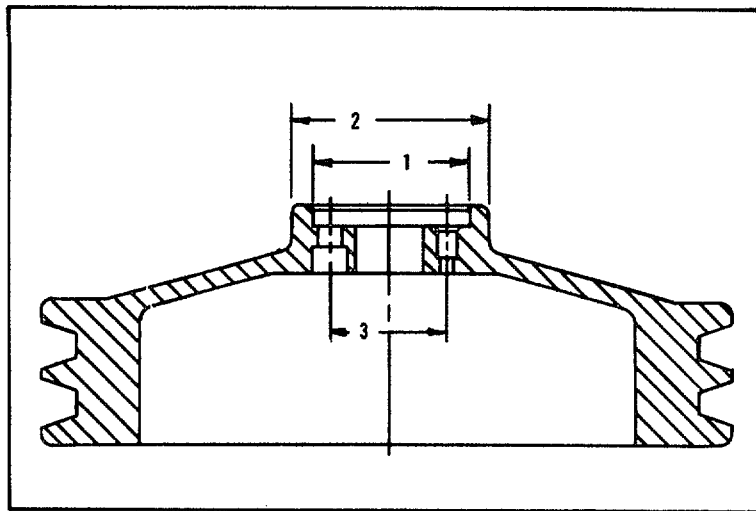

Figure 6-37. Flywheel and Drive Sheave

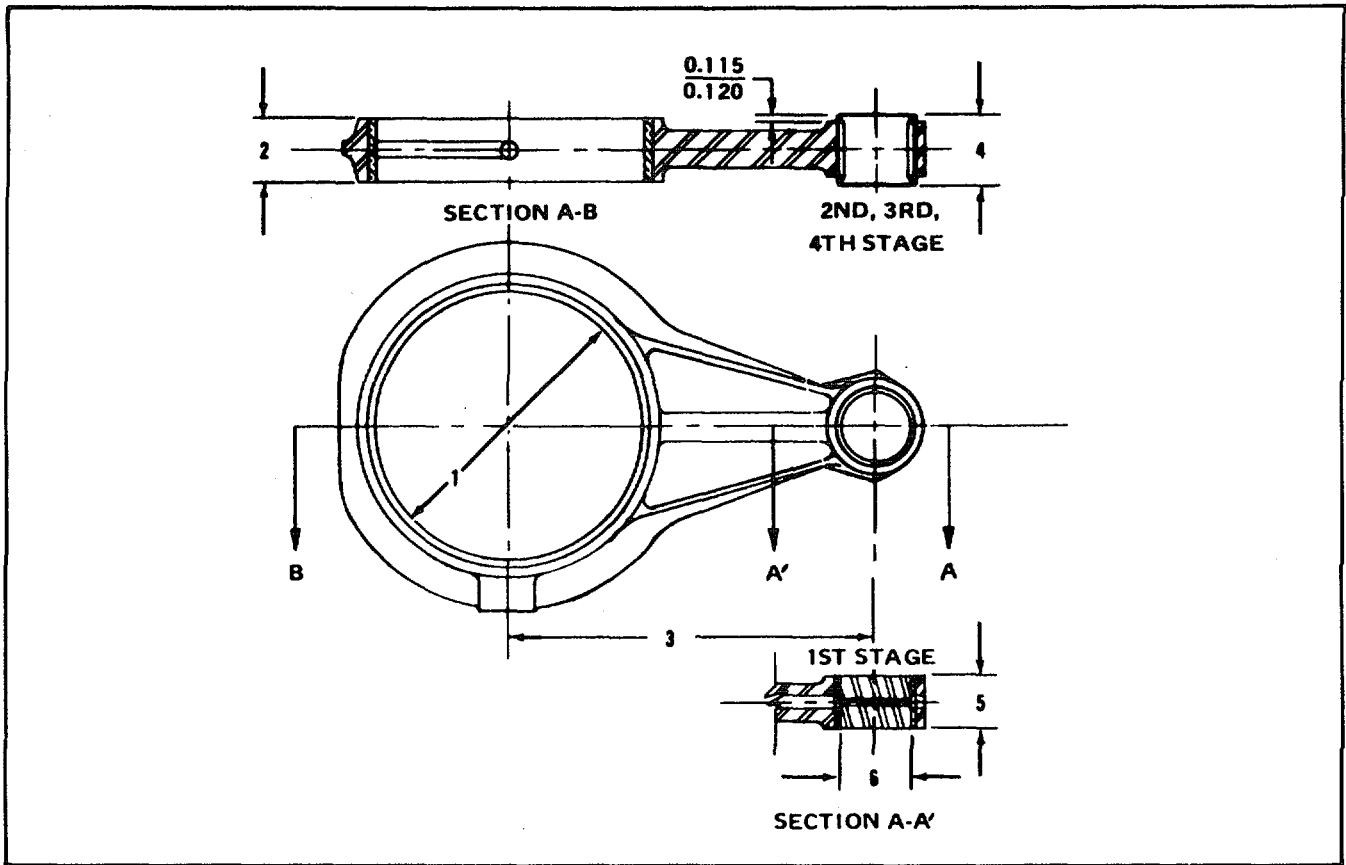

Figure 6-38. Connecting Rods

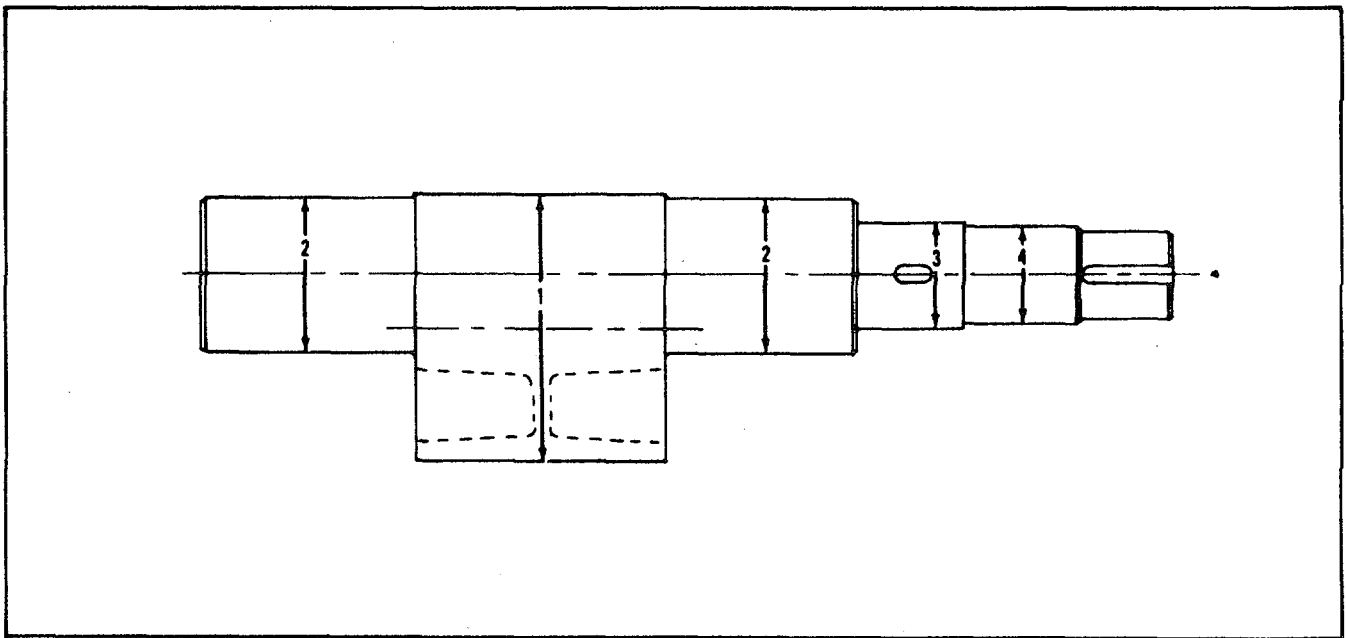

Figure 6-39. Compressor Crankshaft

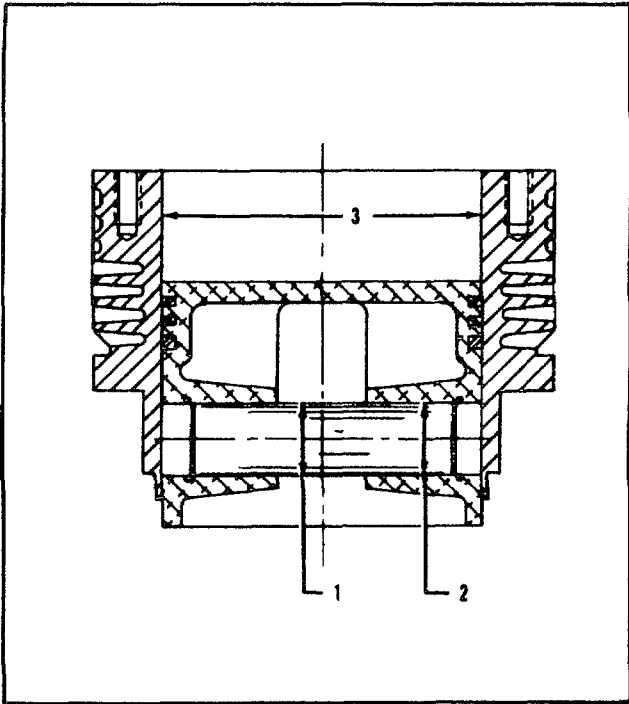

Figure 6-40. First Stage Cylinder, Piston and Pin Assy

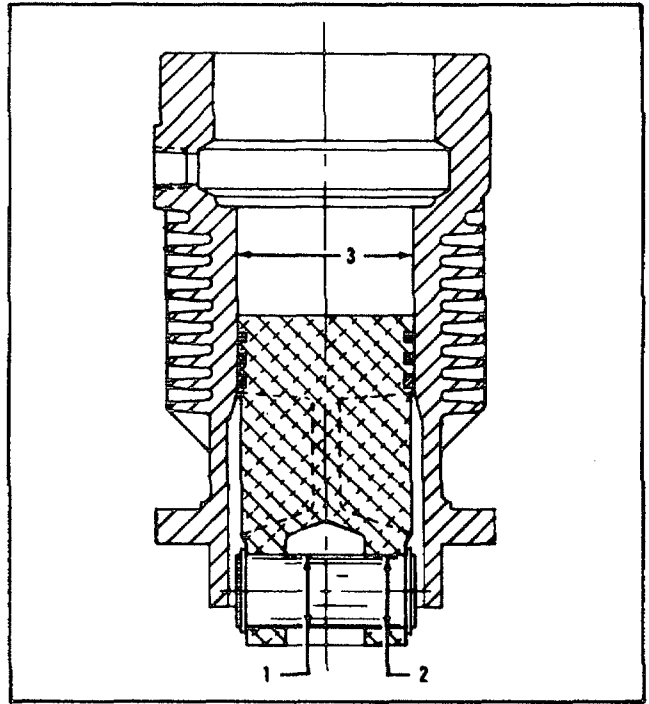

Figure 6-41. Second Stage Cylinder, Piston and Pin Assy

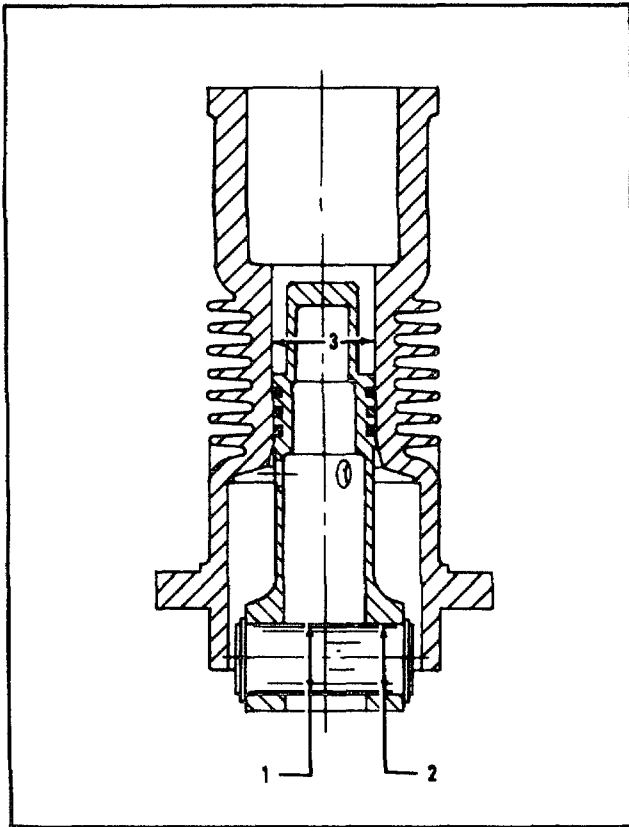

Figure 6-42. Third Stage Cylinder, Piston and Pin Assy

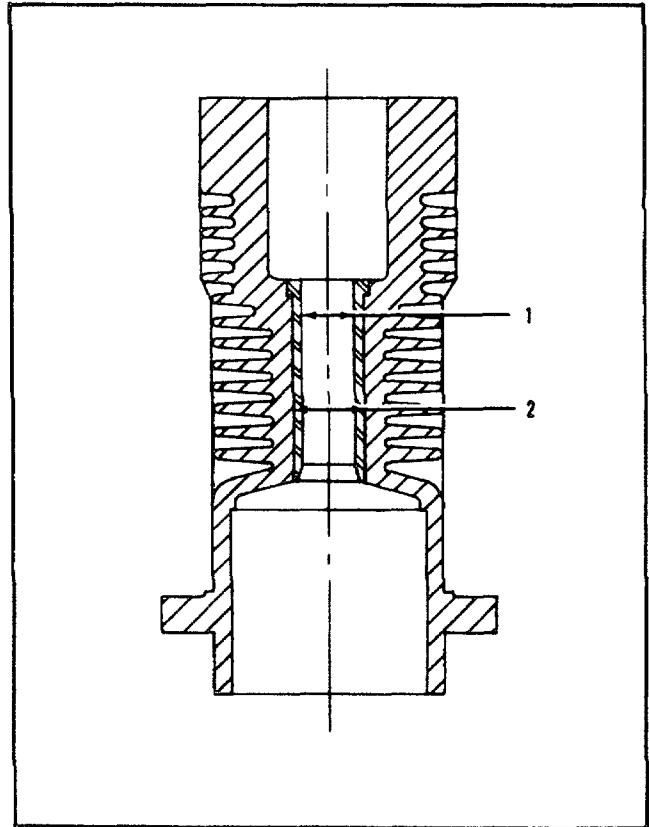

Figure 6-43. Fourth Stage Cylinder and Liner

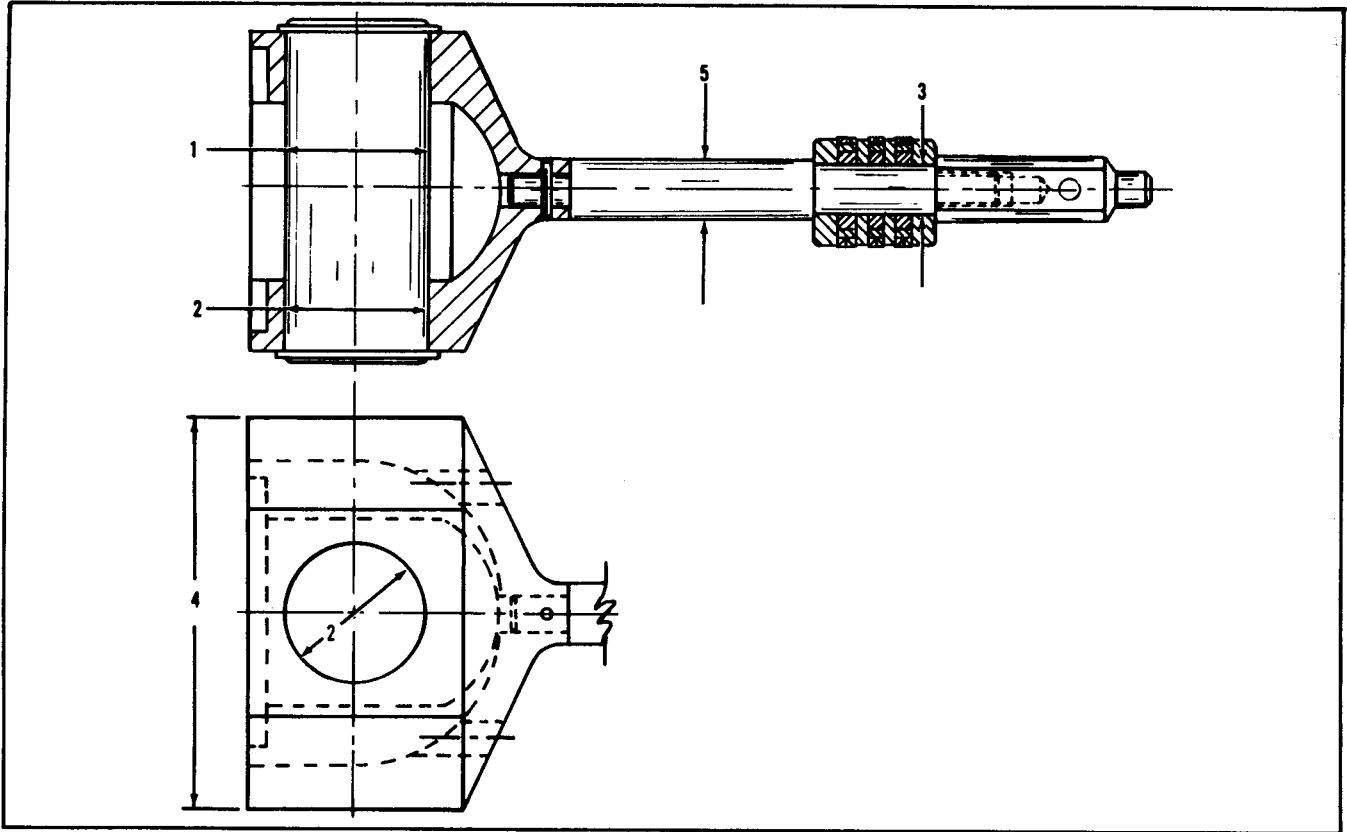

Figure 6-44. Fourth Stage Piston and Pin Assy

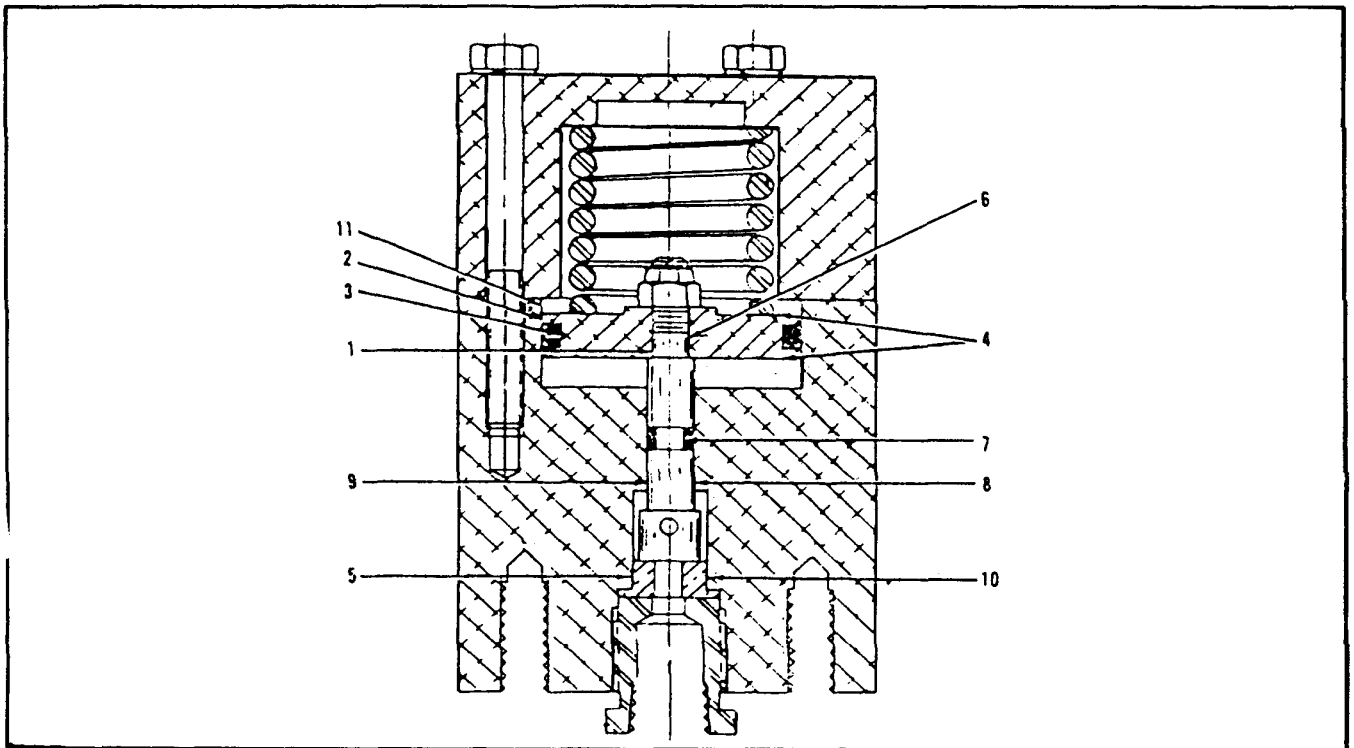

Figure 6-45. Drain Valve Assembly

SECTION VII.

DIAGRAMS

7-1. GENERAL. This section contains the air compressor unit's air flow diagram, tubing diagram, schematic diagram, and wiring diagram. These diagrams are used to analyze and fault isolate, malfunction which may occur in the unit.

7-2. DIAGRAMS. The schematic diagram in this section contains test point identification symbols which identify test points used for voltage checks and continuity checks. The wiring diagram shows the general physical arrangement of the air compressor unit's assemblies and the internal wiring connections.

7-3. SYMBOLS. Electrical symbols used on diagrams in this section are in accordance with American National Standards Institute, Inc. standard, ANSI Y32.2.

7-4. REFERENCE DESIGNATION. All electrical reference designations used on diagrams in this section are in accordance with American National Standard Institute, Inc. standard, ANSI Y32.16.

7-5. INDEX OF DIAGRAMS. All diagrams contained in this section are listed below by figure number, title, and page.

Figure	Title	Page
7-1	Air Compressor Unit Air Service Flow Diagram	7-2
7-2	Air Compressor Unit Electric System Wiring Diagram	7-3

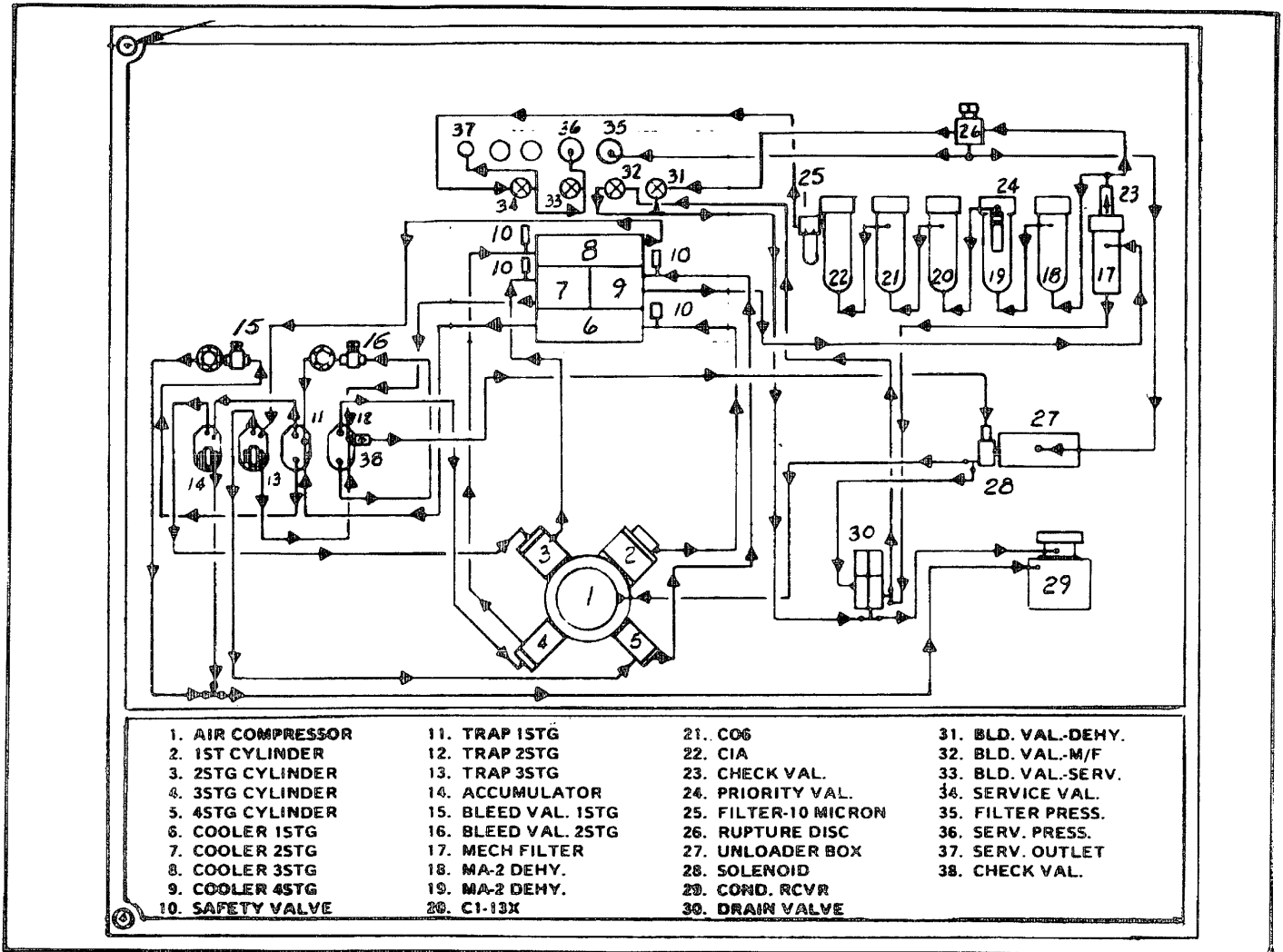

Figure 7-1. Air Flow Diagram

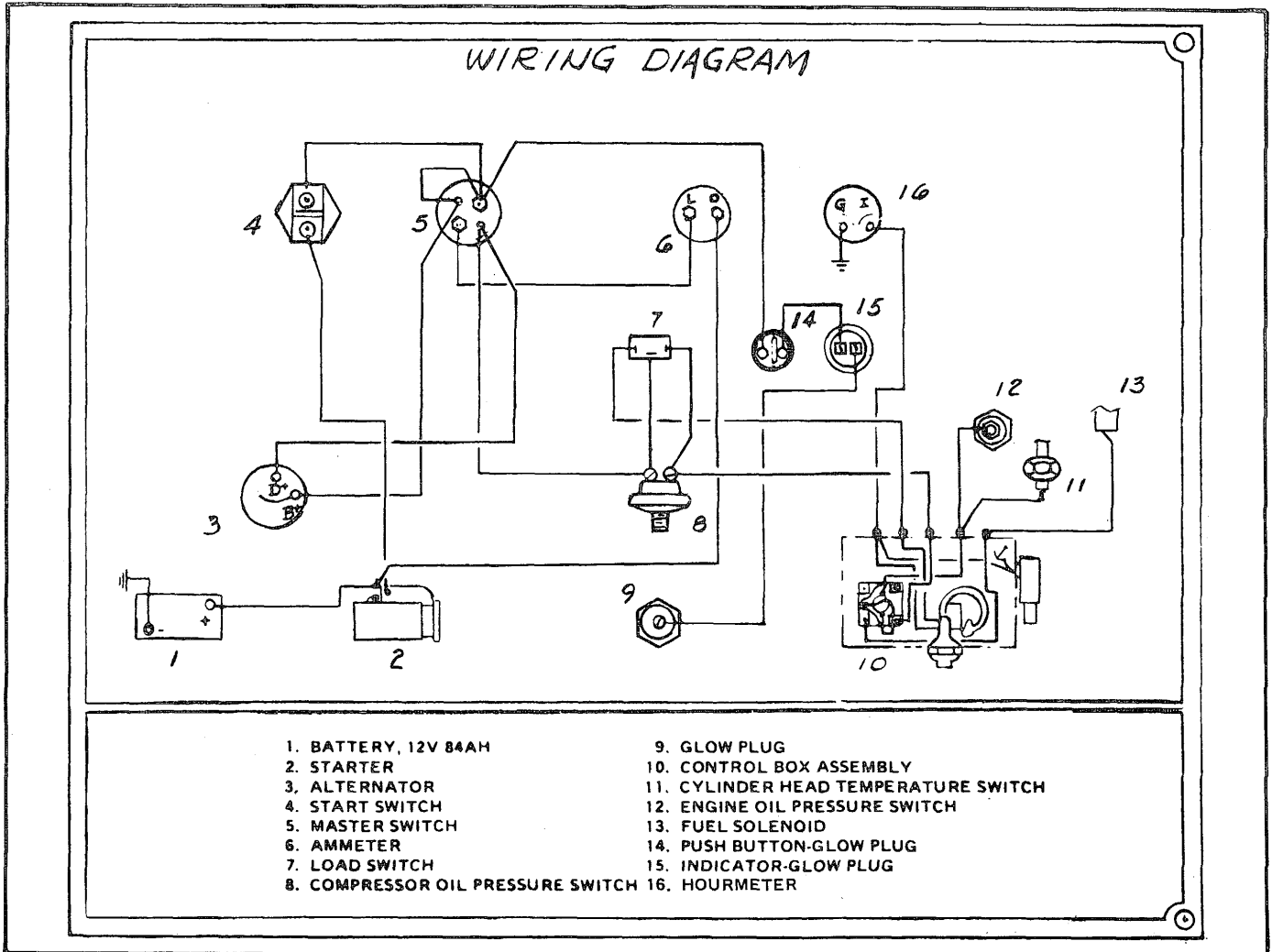

Figure 7-2. Wiring Diagram

7-3/(7-4 Blank)

SECTION VIII.

ILLUSTRATED PARTS BREAKDOWN

8-1. MODEL COVERED. This illustrated parts breakdown covers the Model DMC-AA, diesel engine driven, skid mounted air compressor. The unit is manufactured by Davey Compressor Company (FSCM 16004), Cincinnati, Ohio 45242. Part number 83207 is assigned to the unit assembly.

8-2. PARTS THAT ARE LISTED. In general, the assemblies and parts installed at the time the end items were manufactured are listed and identified in this manual.

When an assembly or part (including vendor items), which is different from the original, is installed during repair, the assembly or part must match form, fit and function. Interchangeable and substitute assemblies and parts are not listed in this manual. When a standard size part can be replaced with an oversize or undersize part, the latter parts, showing sizes, are also listed. Repair Parts Kits and Quick Change Units are listed when they are available for replacement.

8-3. LISTING OF SIMILAR ASSEMBLIES. When similar assemblies contain approximately 51% or more of identical parts, the assemblies are combined and listed as follows.

a. The assemblies are listed first followed by detail parts.

b. A part common to all assemblies in the same quantity is listed once.

c. A part common to all assemblies in differing quantities is listed once for each quantity and identified to which assembly each listing pertains.

d. Parts peculiar to an assembly are listed once and identified to which assembly each pertains.

8-4. PARTS IN KITS. This publication reflects the listing of repair parts kits. Certain replacement parts are stocked only in kits. Standard parts and parts having multi-application are stocked in kits. Kit parts should not be ordered from separate stock to make up a kit.

8-5. When replacement parts of an assembly are available in the form of kits, the words (Repair kit available) follows the description of the applicable assembly. The detail parts of the assembly that are contained in the kit are identified

by a symbol before the part number. A footnote follows the Maintenance Parts List (MPL) to define the symbol. The kit listing follows the last detail part of the assembly in the same indentation as the assembly. Kit source codes, assigned to the kits and their components appear in the SMR column of the Numerical Index, Section VIII.

8-6. SYMBOLS AND ABBREVIATIONS. Symbols and abbreviations used in the MPL are in accordance with Military Standard, MIL-STD-12, or are defined below.

(AP) - This abbreviation, found in the description column, indicates the part is an "attaching part" for the next higher assembly or part.

AR - This abbreviation stands for "as required."

This symbol, inserted flush right following a part number in the MPL for Government Furnished Equipment (GFE) and Contractor Furnished Equipment (CFE), means that detail parts are listed in a separate manual. Refer to "Related Publications" paragraph of this Introduction for publication number, when applicable.

* This symbol, inserted flush right following a part number in the MPL, means "Requisition this marking in accordance with the requirements of AFR 64." The symbol is applied to identifying drawing numbers for decalcomanias, metalcals, and vinyl film markings. When symbol is inserted in front of a part number, footnote at end of parts list should be referenced.

† This symbol, also, †† inserted in front of a part number in the MPL, indicates the footnote at the end of the parts list for that assembly should be referenced. In general, the symbol is used to indicate a component of a kit.

8-7. FEDERAL SUPPLY CODES FOR MANUFACTURERS (FSCM).

These five digit code numbers are used to identify the actual manufacturer of vendor items used in this equipment. The code appears in parentheses in the Description column following the description of the part involved. The applicable codes are listed below. The prime contractor's code is also listed below. The absence of a manufacturer's code in the Description column of the MPL means that the part is the end item manufacturer's part number or commercial off-the-shelf type item that should be ordered by complete description. The following codes have been excerpted from Cataloging Handbook H4-1 and H4-2, Federal Supply Code for Manufacturers.

CODE MANUFACTURER'S NAME AND ADDRESS

04055 East Penn Mfg. Co., Inc.
Deka Road
Lyon Station, PA 19536

06370 Fike Metal Products Corp.
904 S. 10th St.
Blue Springs, MO 64015

09393 Rochester Gauges Inc. of Texas
P.O. Box 20180
Dallas, TX 75220

09527 Faria, Thomas G., Co.
Faria Rd.
Uncasville, CT 06382

16004 Davey Compressor Co.
11060 Kenwood Rd.
Cincinnati, OH 45242

24617 General Motors Corp.
3044 Grand Blvd. W.
Detroit, MI 48202

24643 Hoebiger Corp. of America
P.O. Box 8888
Ft. Lauderdale, FL 33309

31211 Motorola Automotive Products Div.
1299 E. Algonquin Rd.
Motorola Center
Schamburg, IL 60196

38508 Marsh Instrument Co.,
Unit of General Signal Corp.
3501 W. Howard St.
P.O. Box 1011
Skokie, IL 60076

76005 Lord Kinematics, Lord Corp.
1635 West 12th St.
Erie, PA 16512

77308 Plastic and Rubber Products Co.
2150 Parco Ave.
Ontario, CA 91764

79470 Weatherhead Co., The
300 East 131st Street
Cleveland, OH 44108

81860 Barry Div. of Barry Wright Corp.
700 Pleasant
Watertown, MA 02172

82990 Aero-Dri Corp.
11060 Kenwood Rd.
Cincinnati, OH 45242

88044 Aeronautical Standards Group
Dept. of Navy and Air Force
Silver Springs, MD 20900

89326 Barksdale Div. of
Delaval Turbine California Inc.
5125 Alcoa Ave.
Los Angeles, CA 90058

90005 Bendix Corp., The Felter Div.
P.O. Box 135
434 W. Twelve Mile Rd.
Madison Heights, MI 48071

90192 Twin Disc Inc.
1310 Preston St.
Rockford, IL 61102

91816 James Pond and Clark Div., Circle Seal
Corp.
P.O. Box 3666
Anaheim, CA 92803

98660 Flodar Corp., Div. of
Alco Standard Corp.
16911 St. Clair Ave.
Cleveland, OH 44110

8-8. USABLE ON CODES. Only one configuration of the Type DMC-AA air compressor unit is covered in this publication. Usable On Codes will be assigned to additional configurations as necessary. The absence of a code in the Usable On Code column of the MPL indicates that parts listed are usable as replacements on all configurations covered by this publication.

8-9. RELATED PUBLICATIONS. Publications used in conjunction with this Illustrated Parts Breakdown are:

T.O.00-25-223 - Integrated Pressure Systems and Components (Portable and Installed).

T.O.34YI-171 - Installation, Operation, Maintenance and Inspection Instructions for Air Compressors.

T.O.35-14 - Processing and Inspection of Aero Space Ground Equipment for Storage and Shipment.

TM 9-2330-202-14P - Operator, Organizational, and Field Maintenance Instructions, Repair Parts and Special Tools List for Chassis: Trailer, 3/4 Ton, 2-wheel. M 116 and MI16A1.

HOW TO USE THE ILLUSTRATED PARTS BREAKDOWN

IF YOU *Don't* KNOW THE PART NUMBER ...

Do This

- 1 Refer to illustration list and select the illustration most likely to contain the desired part.
- 2 Refer to the page number indicated and find desired part on illustration.
- 3 Note the Figure Number of the illustration and the Index Number of the part. Refer to the corresponding Figure-Index Number on the Assembly List page for Part Number, Nomenclature, etc.

TABLE OF CONTENTS

Page	Section	Page
...
2-20	Blowdown valve assembly	2-20

Figure 10.

FIG. NO.	INDEX	PART NUMBER	DESCRIPTION
10-			
-3		MS150465	

2-20

Figure 8-0. How to Use Illustrated Parts Breakdown, Example

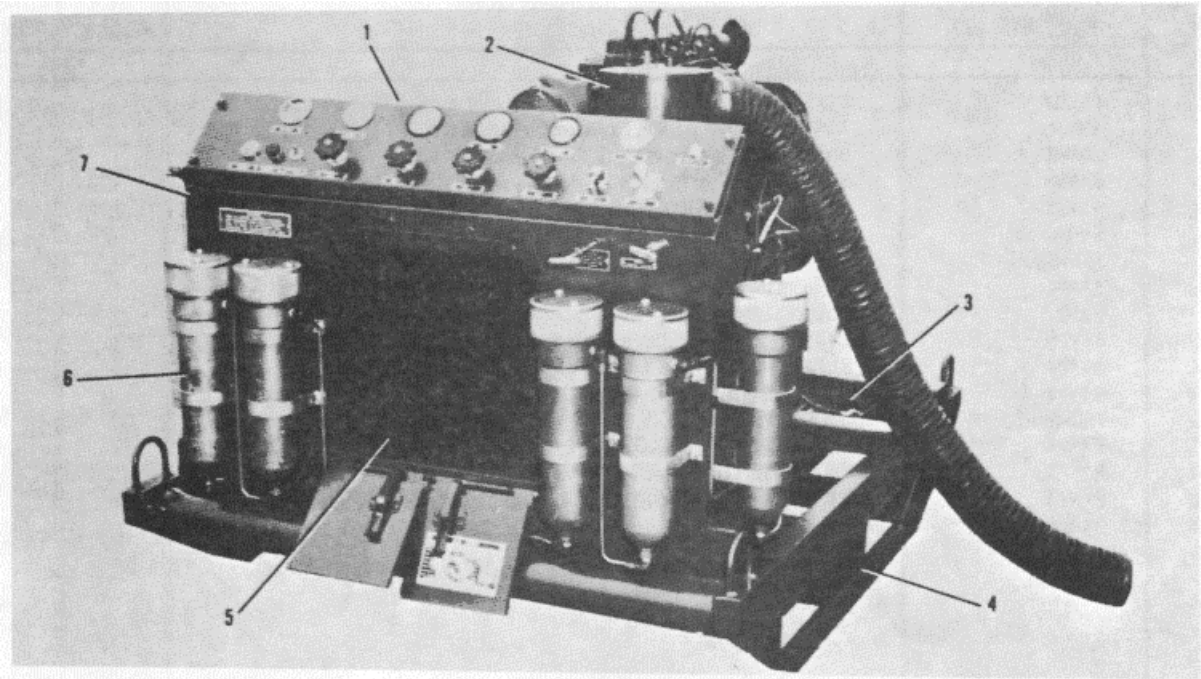

FRONT

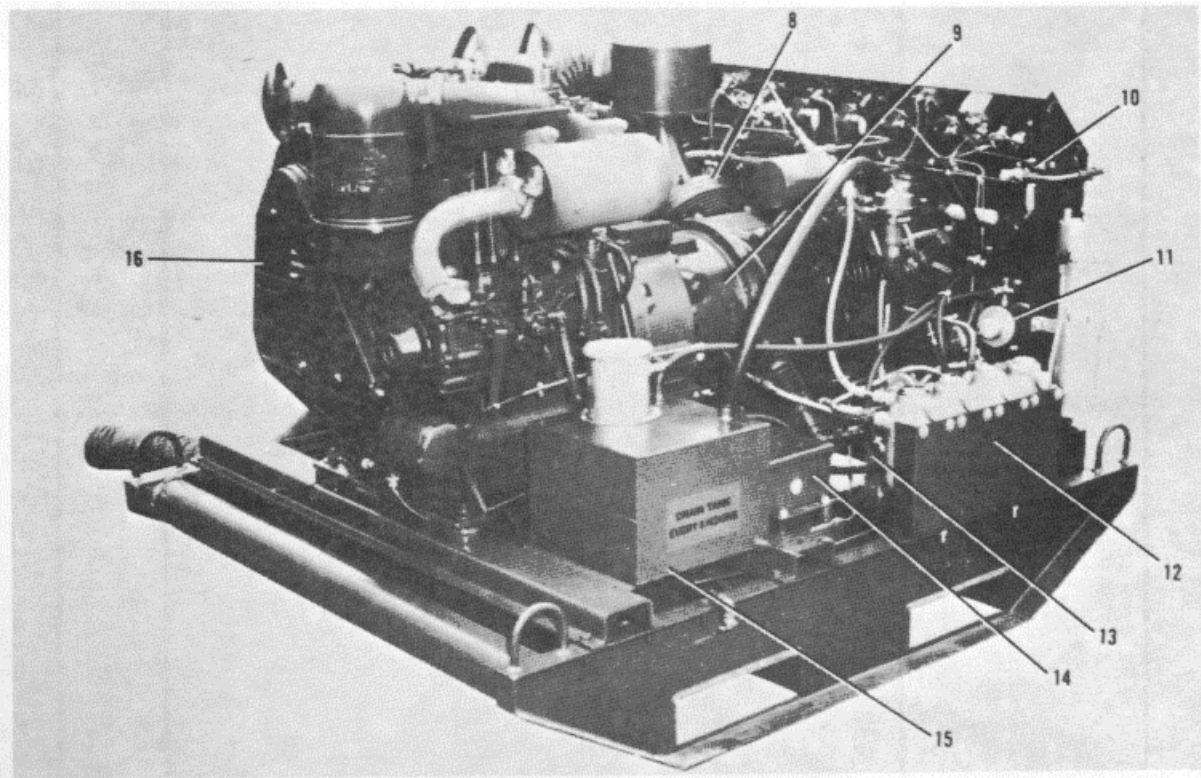

LEFT SIDE REAR

Figure 8-1. Air Compressor Unit

FIGURE & INDEX NUMBER	PART NUMBER	DESCRIPTION	UNITS PER ASSY	USABLE ON CODE
		1 2 3 4 5 6 7		
8-1	83207	•AIR COMPRESSOR UNIT.....	1	
-1	83370	•INSTRUMENT PANEL ASSY (See figure 8-8).....	1	
-2	83606	•AIR CLEANER ASSY, Compressor (see figure 8-13) ...	1	
-3	83990	•BATTERY BOX SUPPORT (See figure 8-37).....	1	
4	83334	•FRAME GROUP (See figure 8-37).....	1	
-5	83986	•AIR COOLER GROUP (See figure 8-10)	1	
-6	No Number	•DEHYDRATOR AND AIR PURIFICATION GROUP (See figure 8-2) . 1		
-7	83338	•CONTROL PANEL ASSY (See figure 8-7)	1	
-8	83227	•AIR COMPRESSOR, 20 CFM (See figure 8-11).....	1	
-9	66500	•CLUTCH HOUSING GROUP (See figure 8-19).....	1	
-10	84526	•RUPTURE DISC ASSY (See figure 8-9).....	1	
-11	84524	•BLEED VALVE ASSY (See figure 8-25)	1	
-12	No Number	•TRAP GROUP (See figure 8-20)	1	
-13	84525	•DRAIN VALVE ASSY (See figure 8-27)	1	
-14	83984	•UNLOADER CONTROL BOX ASSY (See figure 8-28)..	1	
-15	84695	•CONDENSATE RECEIVER BOX ASSY (See figure 8-29)	1	
-16	84000	•DIESEL ENGINE ASSY (See figure 8-30)	1	
		8-6		

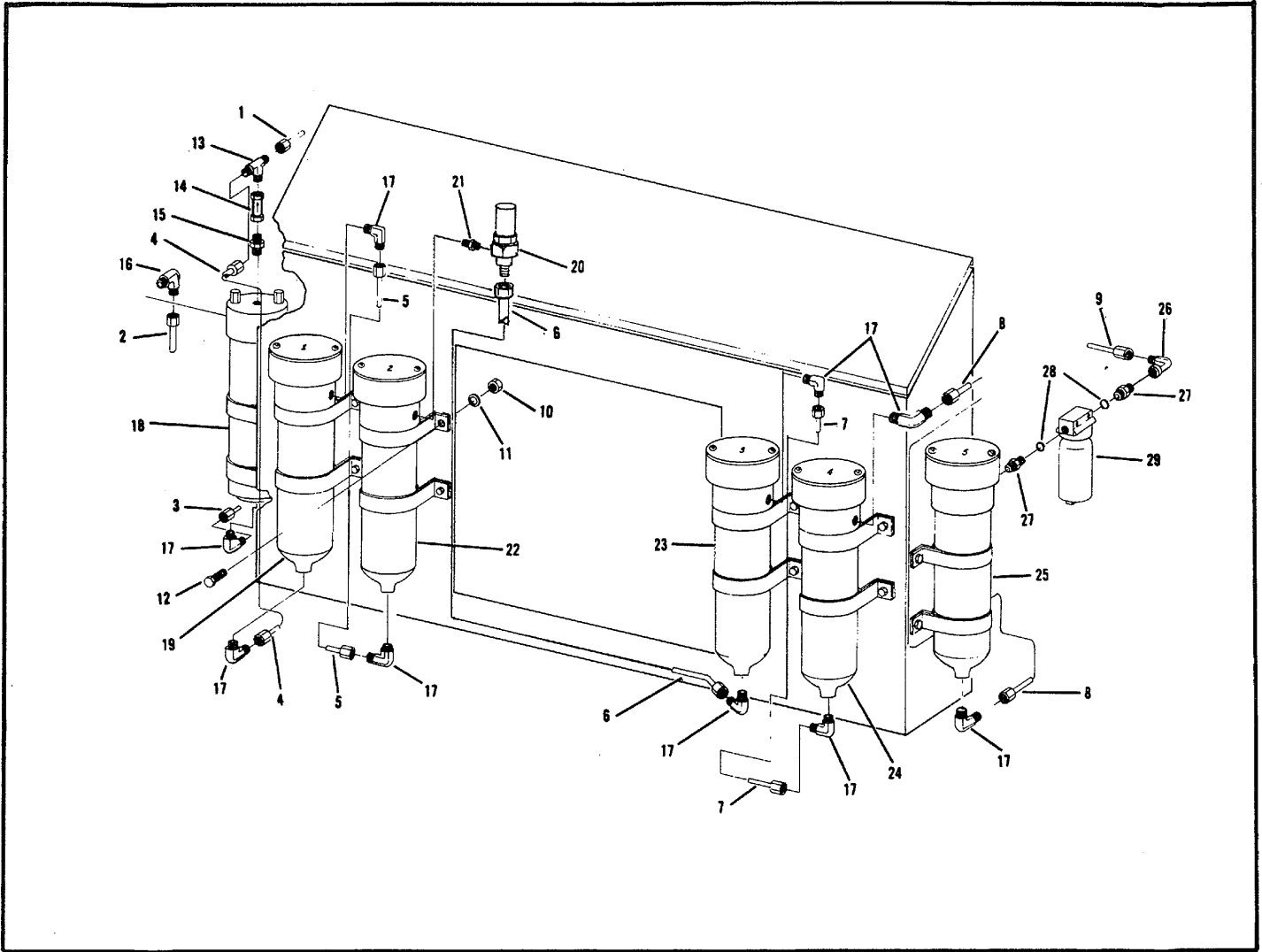

Figure 8-2. Dehydrator and Air Purification Group

FIGURE & INDEX NUMBER	PART NUMBER	DESCRIPTION 1 2 3 4 5 6 7	UNITS PER ASSY	USABLE ON CODE
8-2	No Number	DEHYDRATOR AND AIR PURIFICATION GROUP..... (See figure 8-1 for NHA)	REF	
-1	84893	·TUBE ASSY, Rupture disc to tee	1	
-2	84875	·TUBE ASSY, 4th stage cooler to mechanical filter	1	
-3	84919	·TUBE ASSY, Mech. filter to drain valve	1	
-4	84878	·TUBE ASSY, Mech. filter to cyl no. 1	1	
-5	84883	·TUBE ASSY, Cyl no. 1 to cyl no. 2.....	1	
-6	84887	·TUBE ASSY, Priority valve to cyl no. 3	1	
-7	84883	·TUBE ASSY, Cyl no. 3 to cyl no. 4	1	
-8	84889	·TUBE ASSY, Cyl no. 4 to cyl no. 5.....	1	
-9	84888	·TUBE ASSY, Ten-micron filter to service valve.....	1	
-10	443335	·NUT, Hex lock (24617).....	24	
-11	120394	·WASHER, Flat, 3/8" (24617)	24	
-12	120233	·SCREW, Hex hd, 3/8-16 x 1" (24617)	24	
-13	29397	·TEE, Male, 1/4Tx 1/4Tx 1/4NPT.....	1	
-14	2359B-2PP	·VALVE, Check (91816) (65373).....	1	
-15	65610	·NIPPLE, Hex, std, 1/4 x ¼.....	1	
-16	28843	·ELBOW, 900, 1/4NPT x 3/8T	1	
-17	28842	·ELBOW, 900, 1/4 x ¼	9	
-18	MF-1-5850	·MECHANICAL FILTER ASSY (82990) (See figure 8-3).	1	
-19	82991	·DEHYDRATOR CYL NO. 1 ASSY, Air (82990) (65335) (see figure 8-4)	1	
-20	85456	·VALVE, Priority (see figure 8-5)	1	
-21	66454	·NIPPLE, Hex, Reduce. 1/8 x ¼	1	
-22	82991	·DEHYDRATOR CYL NO. 2, Air (82990) (65353)	1	
-23	82991	·AIR PURIFICATION ASSY, Cyl no. 3, air (82990) (65353) (see figure 84)	1	
-24	82991	·AIR PURIFICATION ASSY, Cyl no. 4, air (82990) (65353) (see figure 8-4)	1	
-25	82991	·AIR PURIFICATION ASSY, Cyl no. 5, air (82990) (65343) (see figure 8-4)	1	
-26	84686	·ELBOW, 900, 1/4P x 1/4T	1	
-27	28719	·ADAPTOR, Straight, 1/4NPT x 9/16T	2	
-28	28788	·PACKING, Preformed o-ring (77308)	2	
-29	574600	FILTER, Ten-micron, air (90005) (28057) (see figure 8-6).		1

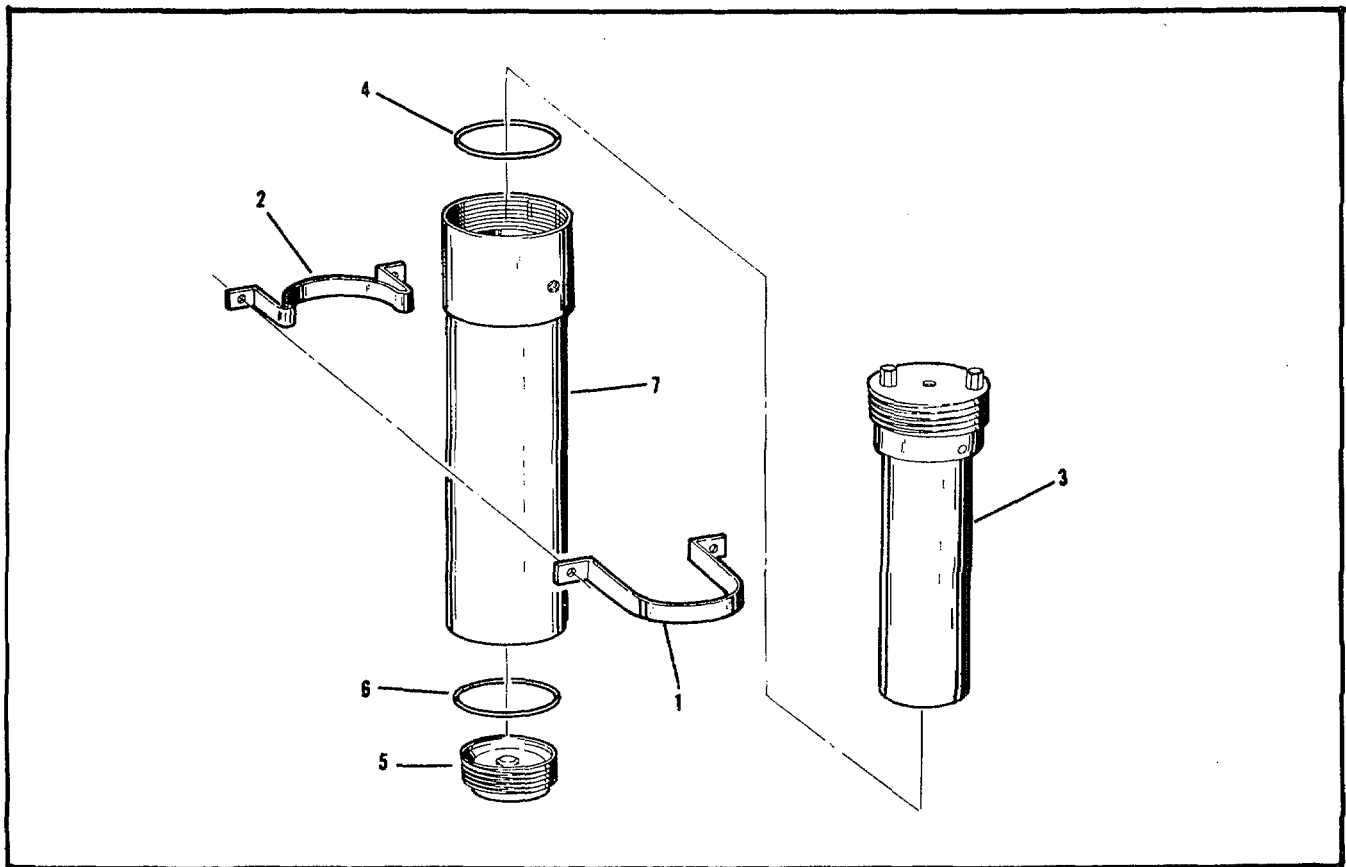

Figure 8-3. Mechanical Filter Assembly

FIGURE & INDEX NUMBER	PART NUMBER	DESCRIPTION							UNITS PER ASSY	USABLE ON CODE
		1	2	3	4	5	6	7		
8-3	MF-1-5850	FILTER ASSEMBLY, Air, mechanical (82990) (65354) (see figure 8-2 for NHA)							REF	
-1	MB-1-5821	·BRACKET, Mounting, upper (82990)							2	
-2	MB-1-5822	·BRACKET, Mounting, lower (82990)							2	
-3	MF-1-5857	·ELEMENT AND HD SUBASSY, Filter (82990).....							1	
-4	AN6227-36	·PACKING, Preformed, o-ring (88044)							1	
-5	MB-1-5803	·TAILPIECE, Cylinder (82990).....							1	
-6	AN6227-34	·PACKING, Preformed, o-ring (88044)							1	
-7	MB-1-5801	·CYLINDER, Mechanical, filter (82990)							1	
8-9										

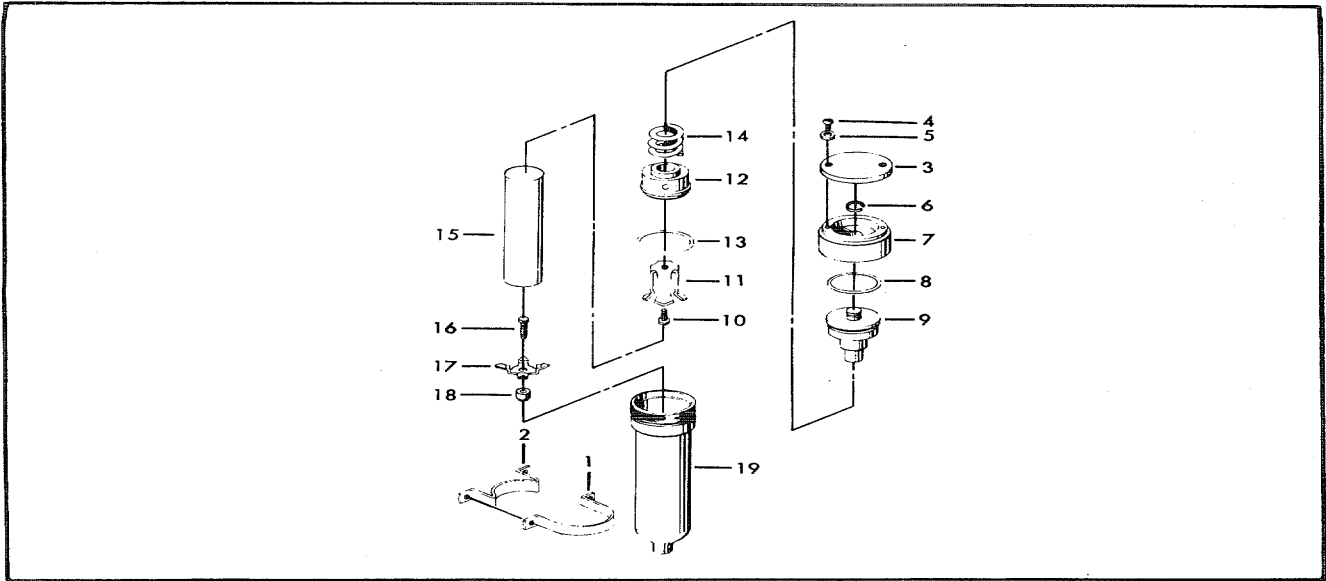

Figure 8-4. Dehydrator Cylinder Assembly

FIGURE & INDEX NUMBER	PART NUMBER	DESCRIPTION	UNITS PER ASSY	USABLE ON CODE
84	82991	DEHYDRATOR CYLINDER ASSEMBLY, Air (82990)..... (see figure 8-23 and 8-35 for NHA) (Davey Spec Cont Dwg 65353)	REF	
-1	83006	·BRACKET, Mounting, upper (82990).....	2	
-2	83005	·BRACKET, Mounting, lower (82990)	2	
-3	82993	·COVER, Dust (82990)	1	
-4	83008	·SCREW, Mach. (AP) (82990)	2	
-5	83009	·GASKET, Cover screw (AP) (82990)	1	
-6	82995	·RING, Retaining (82990)	1	
-7	82994	·CAP, Cylinder (82990)	1	
-8	AN6227-36	·PACKING, Preformed, o-ring (88044)	1	
-9	82996	·HEAD, Upper (82990).....	1	
-10	83000	·SCREW, Hex hd, upper perf rtnr (82990)	1	
-11	82999	·PERFORATOR, Upper (82990)	1	
-12	82997	HEAD, Lower (82990).....	1	
-13	AN6227-35	·PACKING, Preformed, o-ring (88044)	1	
-14	82998	·SPRING, Head (82990)	1	
-15	MA-2	·CYLINDER NO. 1, Cartridge, oxy purifier (82990)..... (MIL-C4952)(19, figure 8-2)	1	
	MA	·CYLINDER NO. 2, Cartridge, oxy purifier (82990)..... (MIL-C-4952)(22, figure 8-2)	1	
	C-1-13X	·CYLINDER NO. 3, Cartridge, oil vapors removed	1	
	CO-6	·CYLINDER NO. 4, Cartridge, carbon monoxide (CO2)	1	
	C-I-AC	·CYLINDER NO. 5, Cartridge, sweetener, air (25	1	
-16	83002	·SCREW, Hex hd, (82990).....	1	
-17	83003	·PERFORATOR, Lower (82990)	1	
-18	83004	SPACER, Perf, lower (82990).....	1	
-19	82992	·CYLINDER, Dehydrator (82990).....	1	

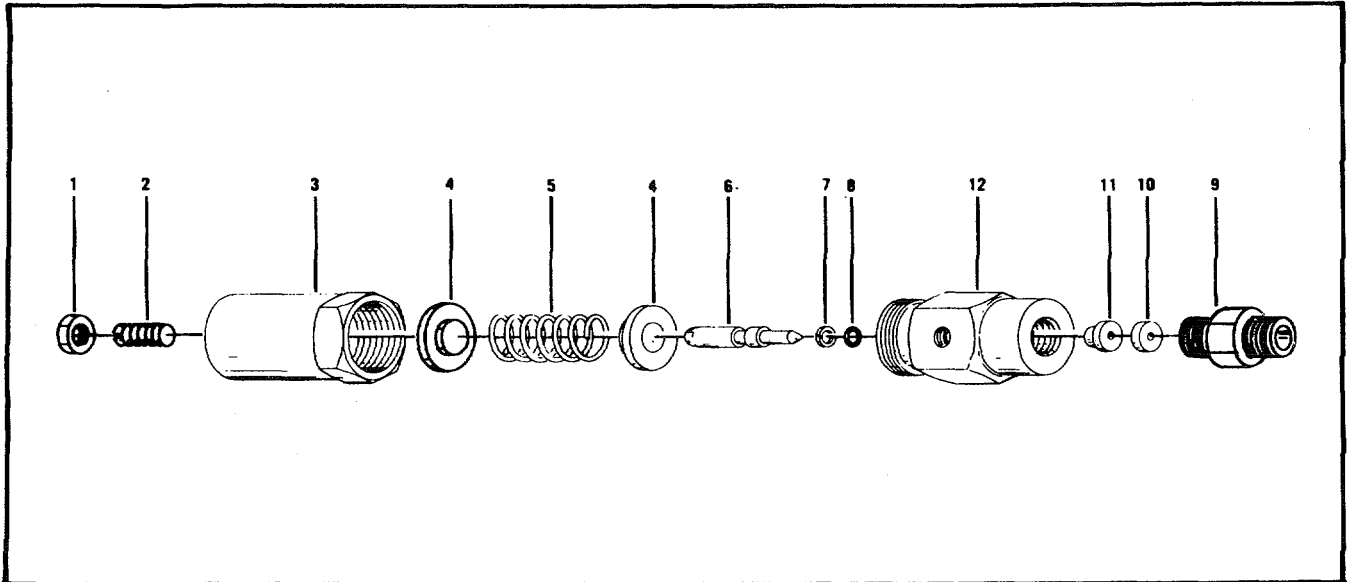

Figure 8-5. Priority Valve Assembly

FIGURE & INDEX NUMBER	PART NUMBER	DESCRIPTION	QTY PER ASSY	USABLE ON CODE
8-5	85456	VALVE ASSY, Priority, (see figure 8-2 for NHA)..... (set valve for 2,300 + 100 psi) (repair kit available)	REF	
-1	MS35691-402	.NUT, Jam, hex, 1/4-20NC (96906)	1	
-2	102379	.SETSCREW, Slotted hd, 1/4-20NC x 3/4 in lg (24617) ...	1	
-3	45110	.HOUSING, Valve	1	
-4	66099	.BUTTON, Spring.....	2	
-5	44938	.SPRING, Valve (KF)	1	
-6	45113	.PLUNGER, Valve (KF).....	1	
-7	44937	.RING, Backup (KF)	1	
-8	44936	.PACKING, Preformed, o-ring (KF)	1	
-9	68063	.CONNECTOR, Straight, 7/16 - 20 x 1/4 T	1	
	MS28778-3	(24617) .PACKING, Preformed, o-ring (96906)	1	
-10	45111	.WASHER, Valve (KF)	1	
-11	45112	.SEAT, Valve (KF).....	1	
-12	45115	.BODY, Valve	1	
-13	MS49005-2	.PLUG, Pipe, sch, 1/8 NPT (96906)	1	
	68501	REPAIR KIT, Field, valve.....	AR	
		8-11		

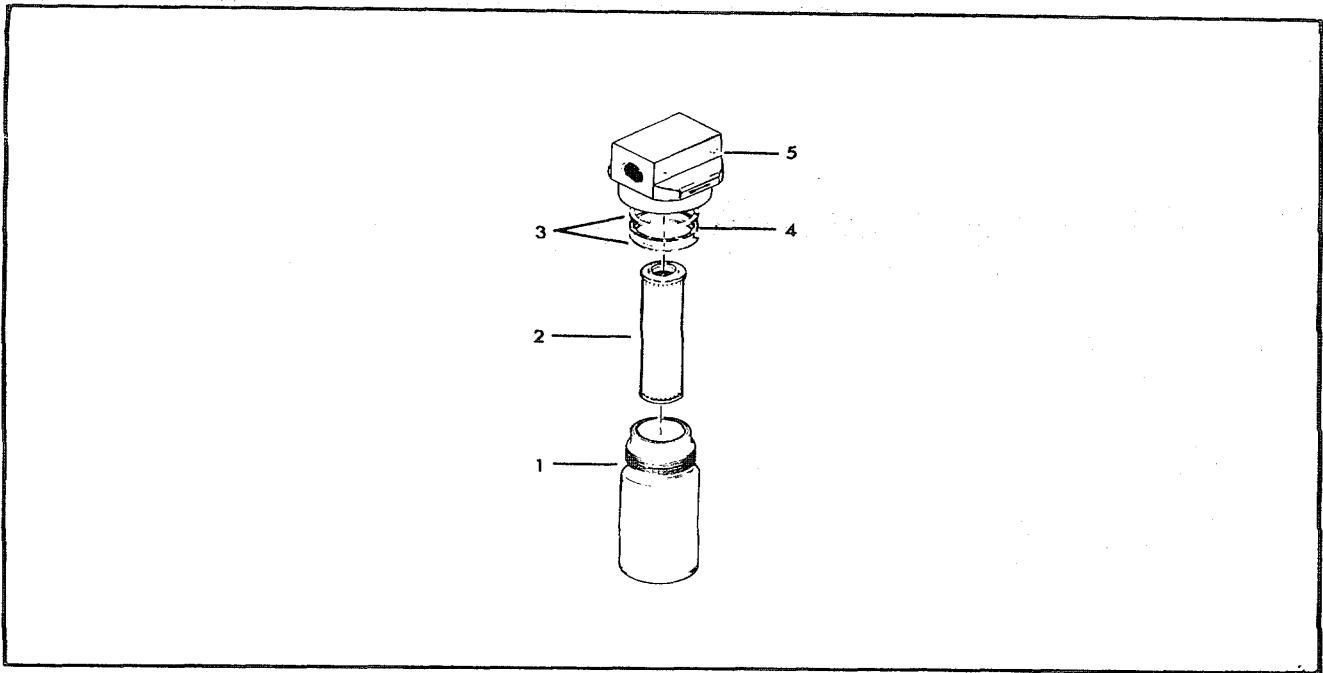

Figure 8-6. Ten-Micron Filter Assembly

FIGURE & INDEX NUMBER	PART NUMBER	DESCRIPTION	QTY PER ASSY	USABLE ON CODE
		1 2 3 4 5 6 7		
8-6	574600	FILTER ASSEMBLY, Air, 10 micron (90005) (28057) (see figure 8-2 for NHA)	REF	
-1	B574577	.BOWL, Filter (90005)	1	
-2	AN6235-2A	.ELEMENT, Filter (88044).....	1	
-3	AN6246-27	.RING, Backup (88044)	2	
-4	AN6227-27	.PACKING, Preformed, o-ring (88044)	1	
-5	B574579	.HEAD, Filter (90005)	1	
		8-12		

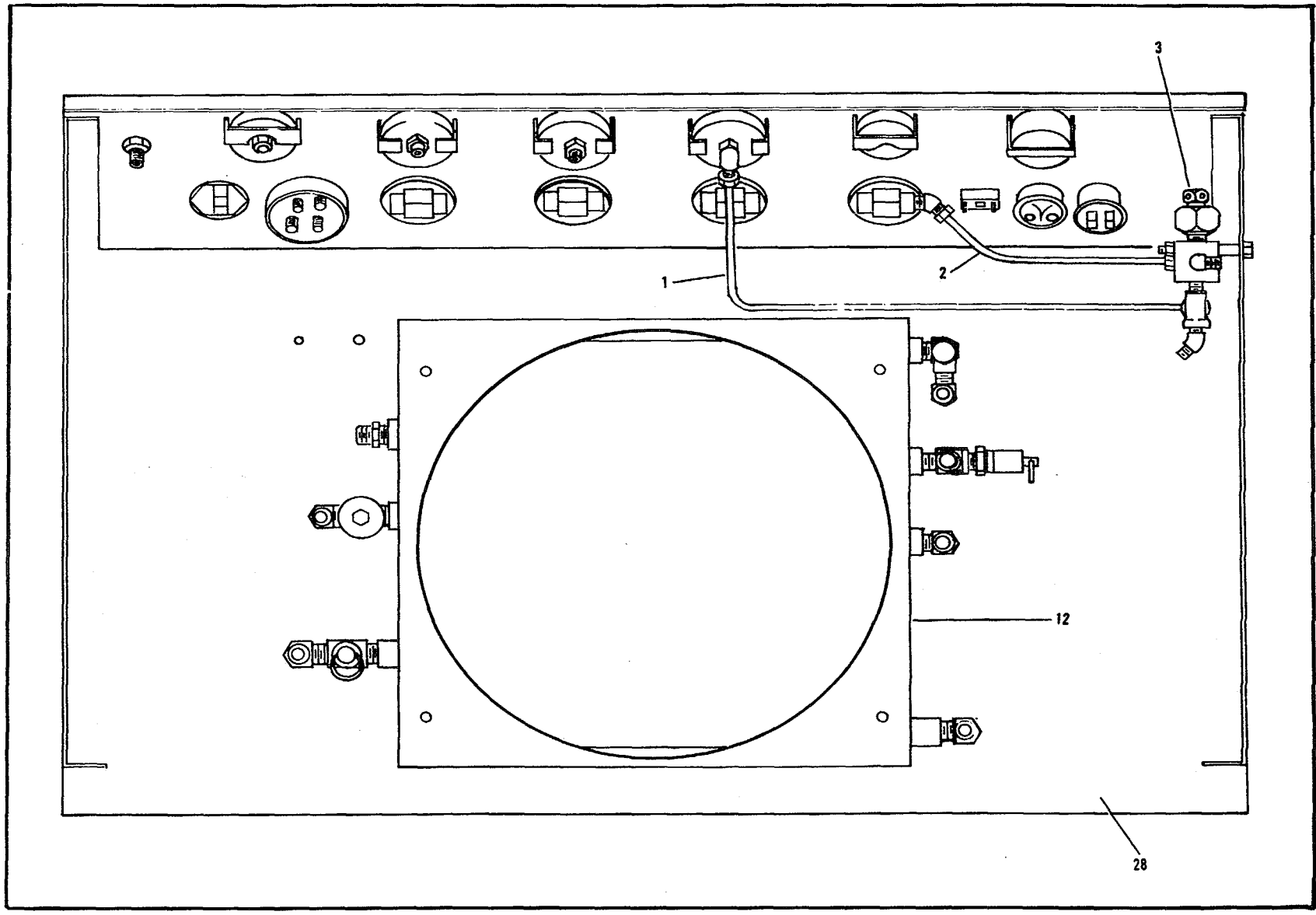

Figure 8-7. Control Panel Assembly (Sheet 1 of 2)

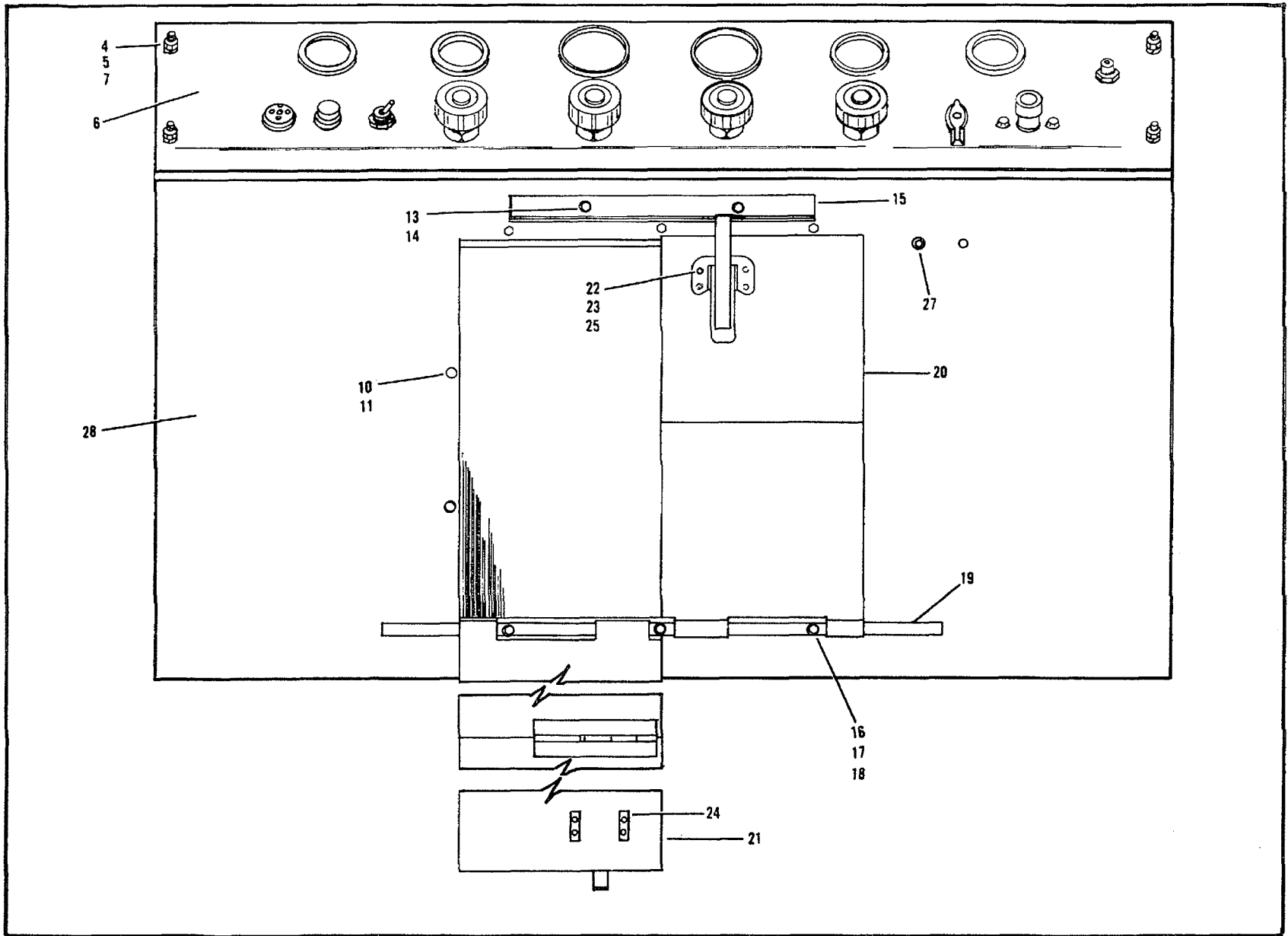

Figure 8-7. Control Panel Assembly (Sheet 2 of 2)

FIGURE & INDEX NUMBER	PART NUMBER	DESCRIPTION							QTY PER ASSY	USABLE ON CODE
		1	2	3	4	5	6	7		
8-7	83338	CONTROL PANEL ASSEMBLY (See figure 8-1 for NHA)1								
-1	84697	.TUBE ASSY							1	
-2	84698	.TUBE ASSEMBLY.....							1	
-3	84526	.RUPTURE DISC ASSY (See figure 8-9)							1	
-4	120376	.NUT, Hex hd, 5/16-18 (AP) (24617)							8	
-5	120214	.WASHER, Lock, split 5/16 (AP) (24617)							8	
-6	83370	.INSTRUMENT PANEL ASSY (See figure 8-8).....							1	
-7	81694-3	.MOUNT, Shock (76005).....							4	
-8	274473	.SCREW, Hex cap 1/4-20 x 5/8 (AP) (29617)							6	
-9	9416918	.NUT, Hex, 1/4-20 (AP) (29617)							6	
-10	436750	.SCREW, Rd h, No 10-32 x 1/2 (AP) (24617)							4	
-11	9411893	.NUT, Lock, No 10-32 (AP) (24617)							4	
-12	83986	.AIR COOLER ASSY (See figure 8-10).....							1	
-13	274473	.SCREW, Hex hd, 1/4-20 x 5/8 (AP) (24617)							3	
-14	9416918	.NUT, Hex, 1/4-20 (AP)							3	
-15	65184	.STRIKE- Door clamp.....							1	
-16	121913	.SCREW, Hex hd, 1/4- 20 x 1-1/4 (AP) (24617)							3	
-17	9416918	.NUT, 1/4-20 (AP) (24617)							3	
-18	120392	.WASHER, Flat, 1/4 (24617)							6	
-19	65185	.BAR, Door slide.....							1	
-20	65183	.DOOR - Cooler, right.....							1	
-21	65182	.DOOR - Cooler, left.....							1	
-22	132646	.SCREW, Rd hd, No 440 x 1/2 (AP) (24617)							8	
-23	131043	.WASHER, Lock, No 4 (AP) (24617)							8	
-24	60725	.PLATE, Nut							4	
-25	47156	.CLAMP, Hook.....							2	
-26	29767	.BUSHING, Clutch rod.....							1	
-27	29763	.RING, Retaining							1	
-28	83339	.PANEL, Control							1	
8-15										

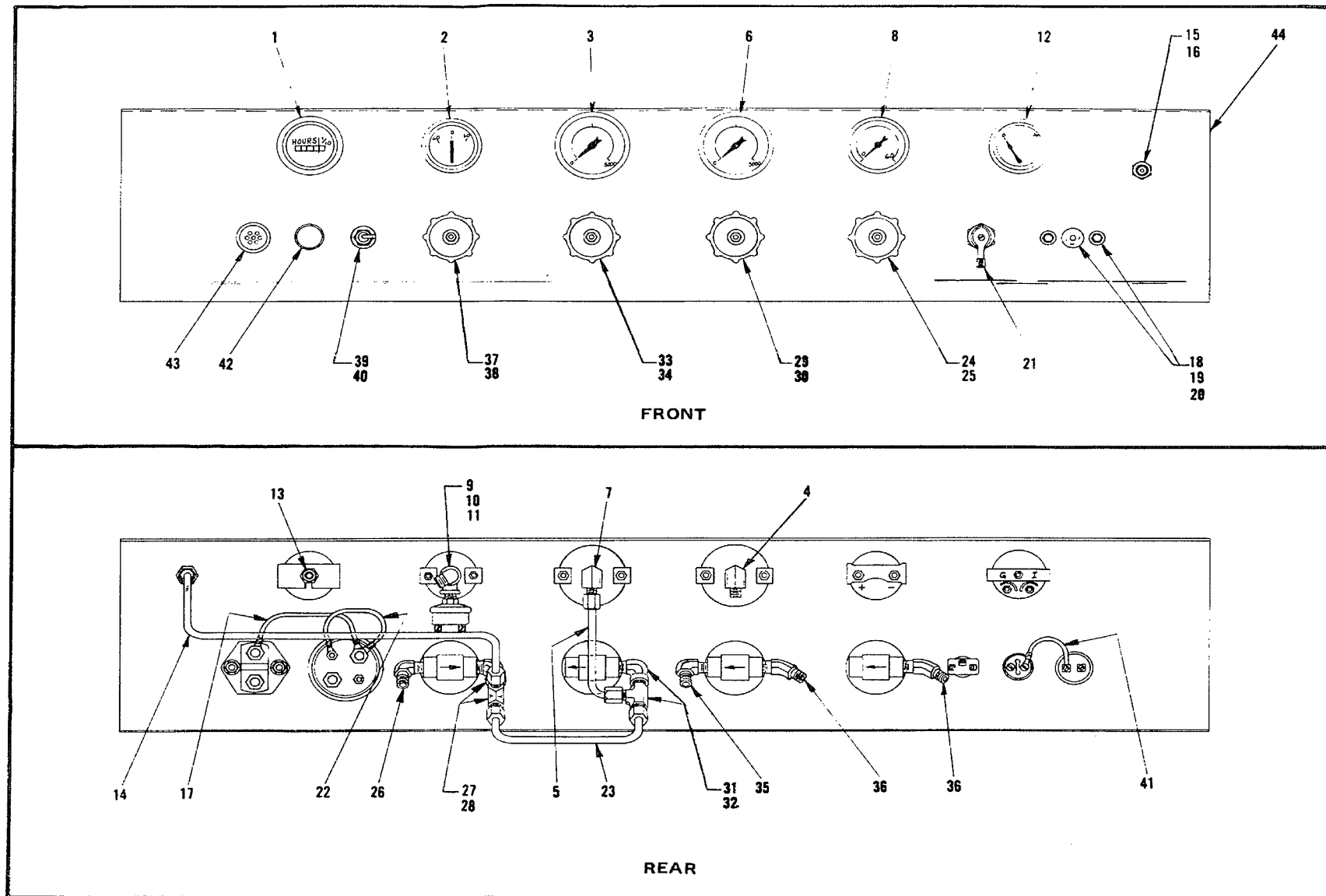

Figure 8-8. Instrument Panel Assembly

FIGURE & INDEX NUMBER	PART NUMBER	DESCRIPTION 1 2 3 4 5 6 7	QTY PER ASSY	USABLE ON CODE
8-8	83370	INSTRUMENT PANEL ASSY (See figure 8-7 for NHA)	REF	
-1	60135	.HOURMETER (31211)	1	
-2	48271	.AMMETER (09527)	1	
-3	69858	.GAUGE, Pressure, compressor	1	
-4	84686	.ELBOW, Female, 1/4 x 1/4 tube, 90°	1	
-5	84691	.TUBE ASSY (To serv. press gauge)	1	
-6	69858	.GAUGE, Pressure, service.....	1	
-7	84686	.ELBOW, 90°, 1/4 x 1/4 tube	1	
-8	65168	.PRESSURE, Gauge, compressor oil (selected fromP/N 1ABB00400AFC002 mfg. by 38508)	1	
-9	63048	.SWITCH, Pressure.....	1	
-10	41899	.ELBOW, 90°, 1/8 to 5/16 tube (brass)	1	
-11	144082	.TEE, 1/8 NPT	1	
-12	2550-108	.PRESSURE GAUGE, Engine oil (09393) (62085)	1	
-13	47947	.CONNECTOR, 1/8 x 5/16 tube.....	1	
-14	84690	.TUBE ASSY, Serv. val to serv. outlet.....	1	
-15	29042	.NUT, Bulkhead.....	1	
-16	28849	.CONNECTOR, Bulkhead	1	
-17	81001-56	.WIRE ASSY, St. switch to mast switch	1	
-18	SW4001	.SWITCH, Start (19728) (08151)	1	
-19	9416918	.NUT, Ser. fig. 1/4-20 (AP) (24617)	2	
-20	274473	.SCREW, Ser. flg. hd, 1/4-20 x 5/8 (AP) (24617)	2	
-21	75903	.SWITCH, Master (13445) (65382)	1	
-22	81001-24	.WIRE ASSY, Mast switch.....	1	
-23	84692	.TUBE ASSY, (Serv. val. to serv. hose bid val.)	1	
-24	949T2PPP	.VALVE, Service (91816) (65372)	1	
-25	131018	.WASHER, Flat 7/8 (24617)	1	
-26	28842	.ELBOW, Male, 1/4 x 1/4 tube, 90°	1	
-27	28852	.TEE, Male, 1/4 x 1/4 x 1/4	1	
-28	29875	.ELBOW, Straight, 1/4 NPT - 90°	1	
-29	949T2PPP	.VALVE, Service hose bleed (91816)	1	
-30	131018	.WASHER, Flat, 7/8 (24617)	1	
-31	28852	.TEE, Male, 1/4 x 1/4 x 1/4	1	
-32	29875	.ELBOW, Straight, 1/4 NPT - 90°	1	
-33	949T2PPP	.VALVE, Mechanical filter drain (91816)	1	
-34	131018	.WASHER, Flat, 7/8 (24617)	1	
-35	28842	.ELBOW, Male, 1/4 x 1/4, 90°	1	
-36	65900	.ELBOW, Make, 1/4 x 1/4, 45°	2	
-37	949T2PPP	.VALVE, Dehydrator bleed (91816)	1	
-38	131018	.WASHER, Flat, 7/8 (24617)	1	
-39	65978	.SWITCH, Unloader	1	
-40	67922	.WASHER, Flat, 1/2 SAE	1	
-41	81001-10	.WIRE ASSY, (Glo plug incl to push button)	1	
-42	69680	.PUSH BUTTON, Glow plug.....	1	
-43	69782	.INDICATOR, Glow plug.....	1	
-44	83359	.PANEL, Instrument	1	
8-17				

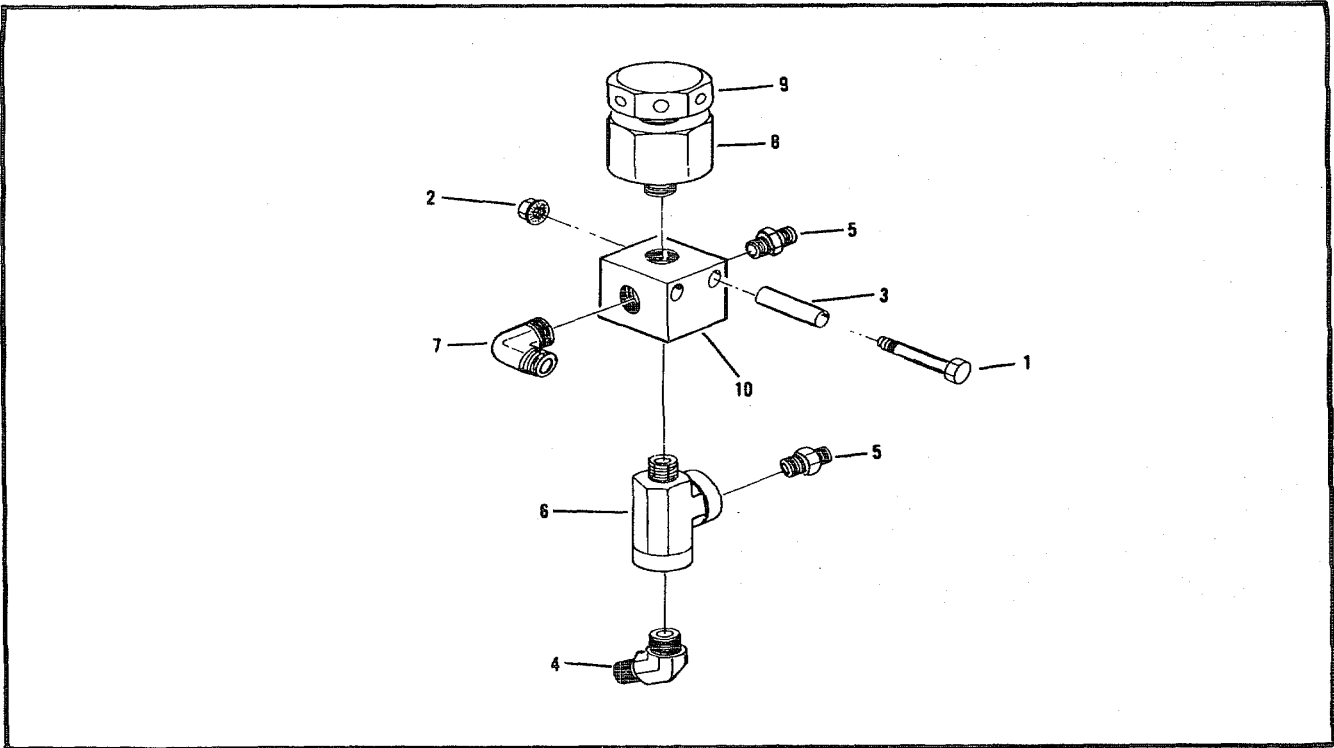

Figure 8-9. Rupture Disc Assembly

FIGURE & INDEX NUMBER	PART NUMBER	DESCRIPTION	QTY PER ASSY	USABLE ON CODE
		1 2 3 4 5 6 7		
8-9	84526	RUPTURE DISC ASSEMBLY (See figure 8-7 for NHA) ...	REF	
-1	179134	.SCREW, Hex hd, 1/4-20 x 2-5/8 lg (24617).....	2	
-2	9416918	.NUT, Sif IIkg, 1/4- 20 (24617)	2	
-3	65873	.SPACER 2		
-4	69280	.ELBOW, 45°, 1/4 pipe to No 4 hose	1	
-5	28836	.CONNECTOR, 1/4 pipe to 114 tube	2	
-6	41024	.TEE, Straight, 1/4 pipe.....	1	
-7	28842	.ELBOW, 1/4 pipe to 1/4 tube	1	
-8	65361	.BASE, Rupture disc (06370) (65361) (NPS).....	1	
-9	66377	.NUT, Cap disc (06370) (66377) (NPS).....	1	
-10	66277	.BODY.....	1	
8-18				

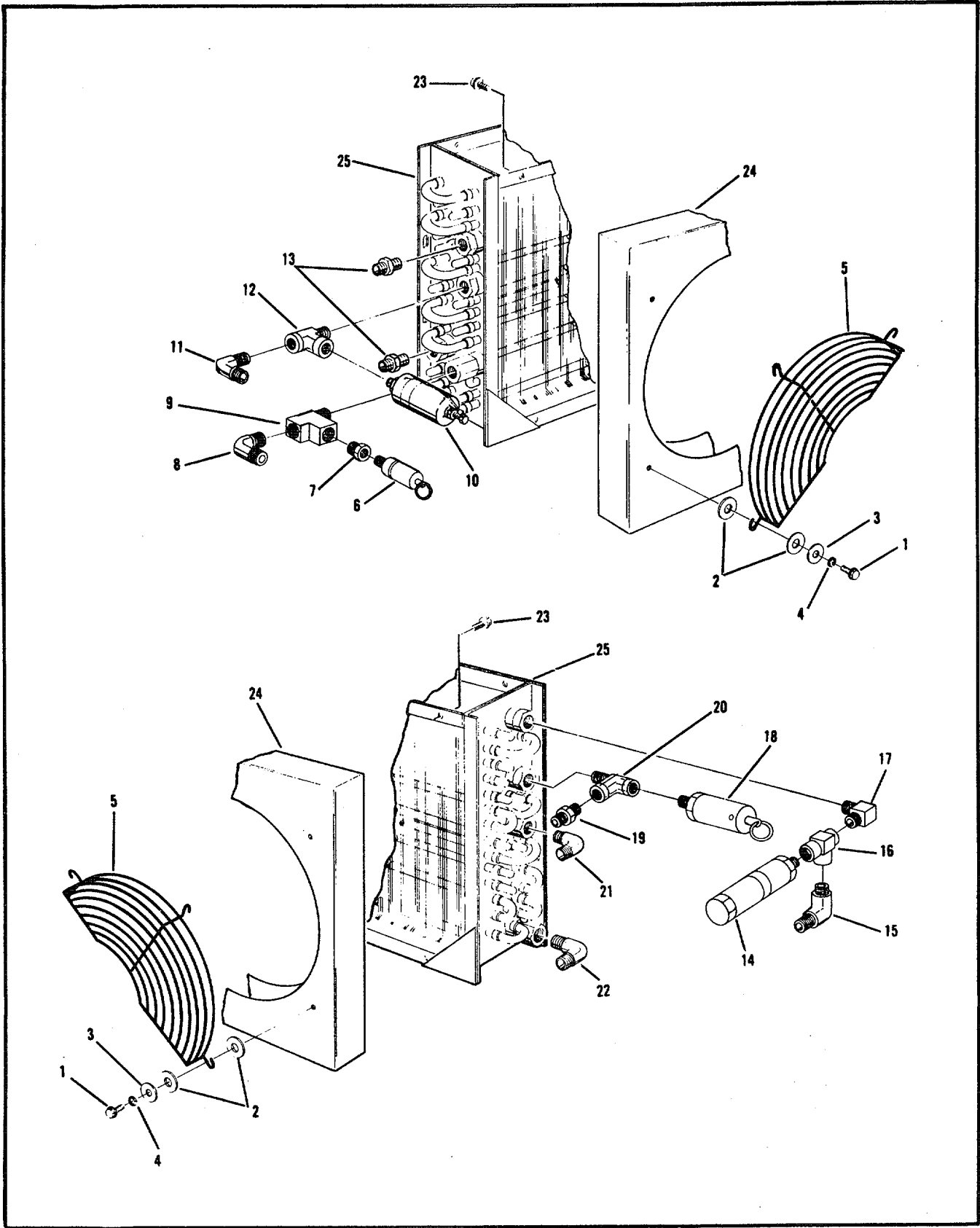

Figure 8-10. Air cooler Group

FIGURE & INDEX NUMBER	PART NUMBER	DESCRIPTION 1 2 3 4 5 6 7	QTY PER ASSY	USABLE ON CODE
8-10	No Number	AIR COOLER GROUP (See figure 8-7 for NHA)	REF	
-1	121900	.SCREW, Cap, hex hd, 1/4-20 x 1 in..... lg (AP) (24617)	4	
-2	62864	.WASHER, Rubber.....	8	
-3	63002	.WASHER, Special.....	4	
-4	120392	.WASHER, Flat, 1/4 in. (AP) (24617)	4	
-5	65193	.GUARD, Fan	1	
-6	48-80-1/4NPT	.VALVE, Safety, 80 PSI, 1st stg (34494) (29771)	1	
-7	116332	.BUSHING, Reducer, 3/8 to 1/4 NPT(24617)	1	
-8	23679	.ELBOW, 90° x 3/8 NPT x 1/2 JIC	1	
-9	68446	.TEE, Street, brass, 3/8 NPT	1	
-10	28122	.VALVE, Safety, 3800 PSI	1	
-11	23680	.ELBOW, 90°x 1/4 NPT	1	
-12	79088	.TEE, Street, 1/4 NPT	1	
-13	28837	.CONNECTOR, 1/4NPTx 3/8 tube	2	
-14	230N1500-1/4NPT	.VALVE, Safety, 1500 PSI (34494) (28121)	1	
-15	23680	.ELBOW, 90° x 1/4 NPT x 3/8 JIC	1	
-16	65609	.TEE, Std, 1/4 NPT	1	
-17	65644	.ELBOW, 90° male, 1/4 NPT	1	
-18	48-240-1/4NPT	.VALVE, Safety, 240 PSI	1	
-19	23670	.CONNECTOR, 1/4 NPT x 3/8 JIC (79420).....	1	
-20	79088	.TEE, Straight, 1/4 NPT (79420)	1	
-21	28843	.ELBOW, 90°, 1/4 NPT x 3/8 tube (79420)	1	
-22	44298	.ELBOW, 90°, 3/8 NPT x 1/2 tube (79420)	1	
-23	9414204	.SCREW, Mach, serr fig hd, 1/4-20 NC x 3/8 in. ..lg (AP) . (24617)	6	
-24	65192	.SHROUD, Fan.....	1	
-25	65376	.COOLER, Air.....	1	
8-20				

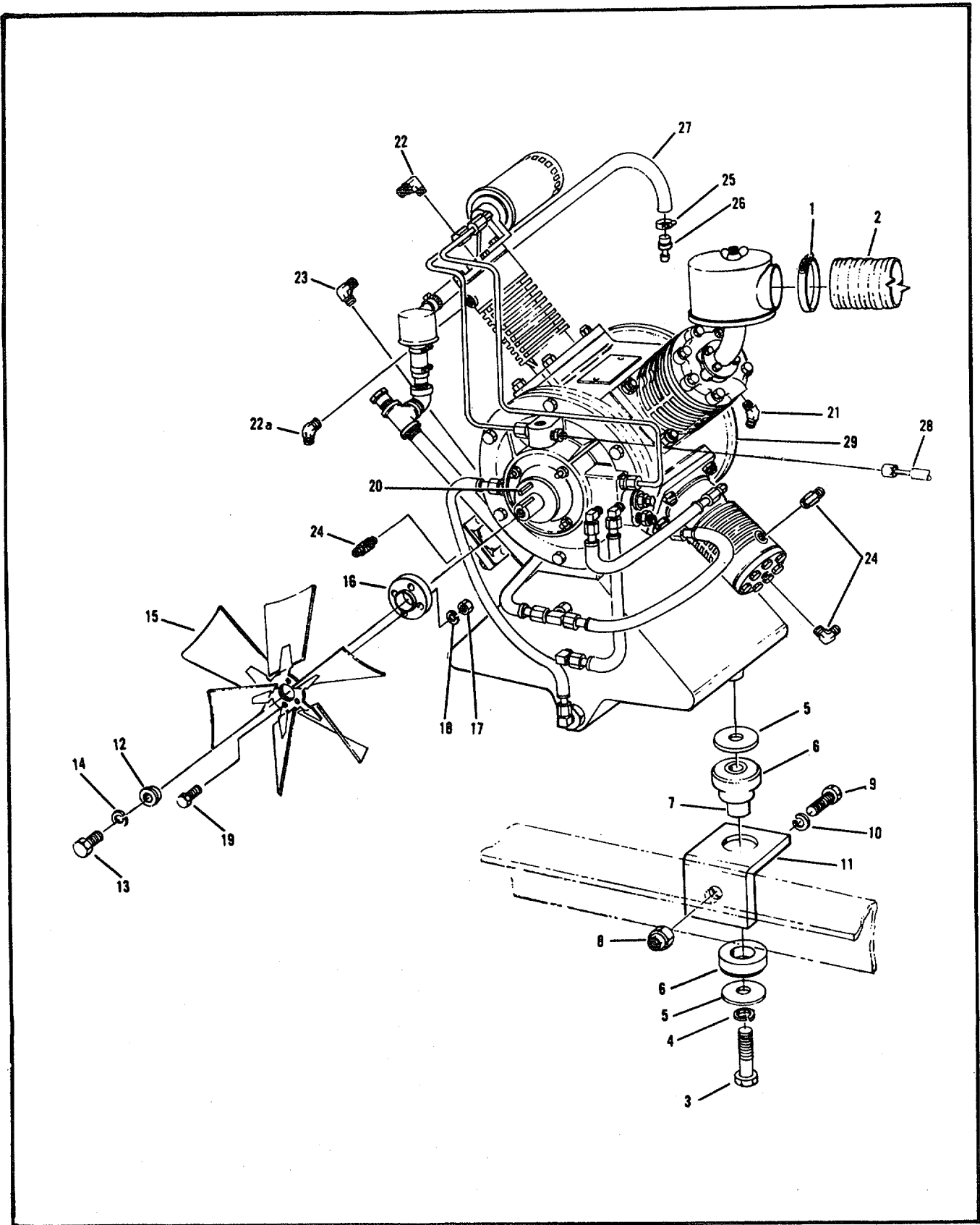

Figure 8-11. Air Compressor Group

FIGURE & INDEX NUMBER	PART NUMBER	DESCRIPTION							QTY PER ASSY	USABLE ON CODE
		1	2	3	4	5	6	7		
8-11	No Number	COMPRESSOR GROUP, Air (see figure 8-1 for NHA)							REF	
-1	61054	.CLAMP, Hose, 4"							1	
-2	83372	.HOSE, Breather 4" x 15'.....							1	
	83335 CAP, End, air intake							1	
-3	122446	.SCREW, Cap, hex hd, 1/2-13 x 1-3/4 (24617)							2	
-4	120384	.WASHER, Lock, split, 1/2 (24617)							2	
-5	80054	.WASHER, Mount							4	
-6	84693	.MOUNT, Shock							2	
-7	80265	.SLEEVE, Shock mount							2	
-8	443339	.NUT, Sflk., 1/2 (24617).....							2	
-9	120426	.SCREW, 1/2-13 x 1-1/4 (24617)							2	
-10	120384	.WASHER, Lock, spit, 1/2" (24617)							1	
-11	83349	.MOUNT, Compressor.....							2	
-12	45546	.WASHER, Hub, fan.....							1	
-13	428217	.SCREW, Cap, hex hd, 5/8-11 NC x 1-1/2 in. lg (AP) (24617) 1								
-14	121574	.WASHER, Lock, split, 5/8 (24617)							1	
-15	65379	.FAN, Compressor							1	
-16	44932	.HUB, Fan, cast iron, ASTM-A 159, grd. 3,000							1	
-17	120376	.NUT, Hex hd, 5/16-18NC (24617)							4	
-18	120214	.WASHER, Lock, split, 5/16 (24617)							4	
-19	122040	.SCREW, Cap hex hd, 5/16-18NC x 1-1/2 (AP) (24617)...							4	
-20	45547	.KEY, Hub, fan.....							1	
-21	69800	.ELBOW, 45°, 3/8 NPT x 1/2 JIC							1	
-22	23679	.ELBOW, 90°, 3/8 NPT x 1/2 JIC							1	
-22a	23680	.ELBOW, 90°, 1/4 NPT x 3/8 JIC							1	
-23	38877	.ELBOW, 45°, 1/4 NPT x 3/8 JIC							1	
-24	28843	.ELBOW, 90°, 1/4 NPT x 3/8 tube, JIC							3	
-25	70844	.CLAMP, Hose.....							2	
-26	84652	.VALVE, PVC							1	
-27	37700	.HOSE, Breather, 5/8 x 30"							1	
-28	46163	.HOSE ASSEMBLY, Compressor oil.....							1	
-29	83227	.COMPRESSOR ASSEMBLY, Air (see figure 8-12 for breakdown)							1	
8-22										

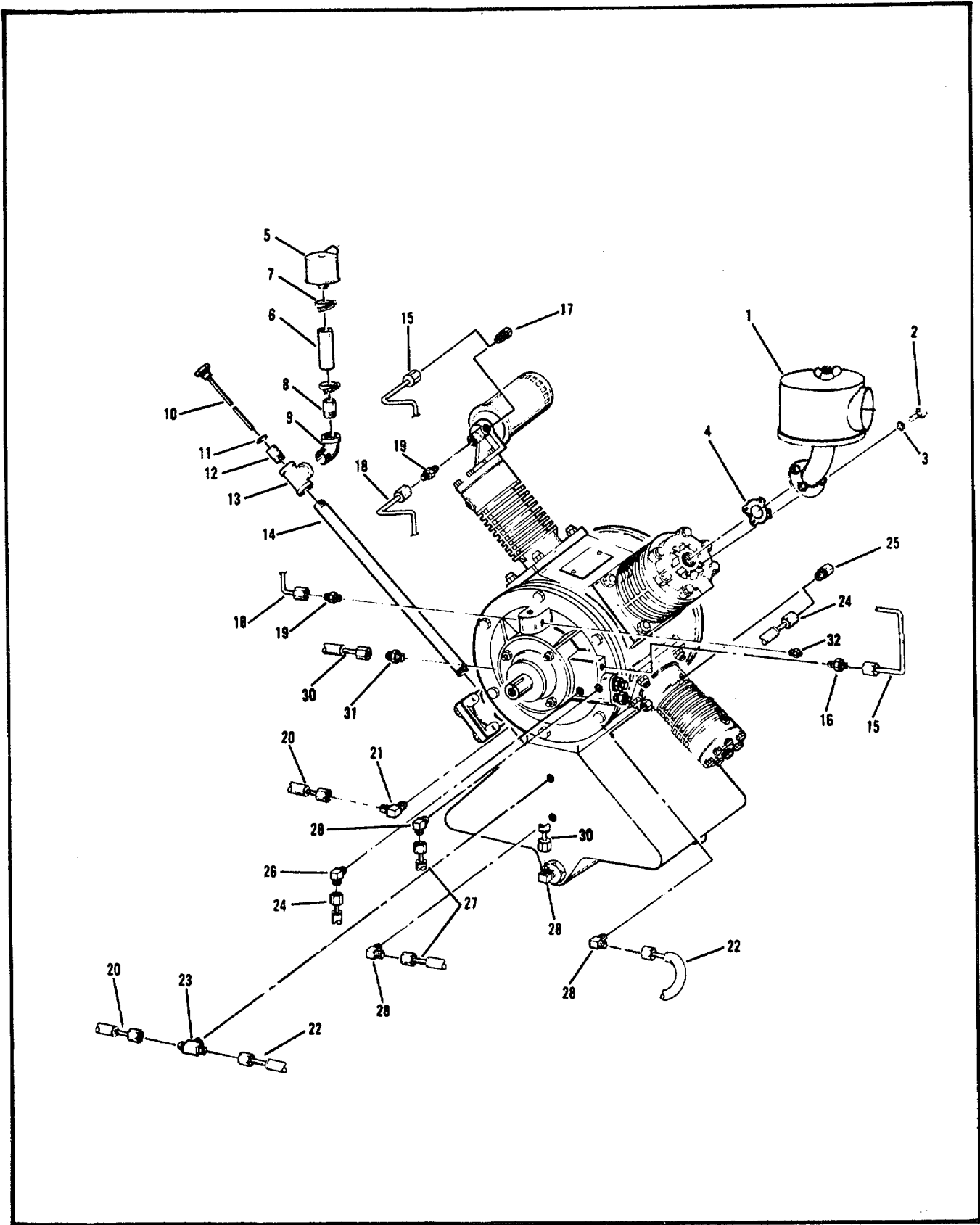

Figure 8-12. Air Compressor Assembly (Sheet 1 of 3)

FIGURE & INDEX NUMBER	PART NUMBER 1 2 3 4 5 6 7	DESCRIPTION	QTY	USABLE
			PER ASSY	ON CODE
8-12	83227	COMPRESSOR ASSY (See figure 8 -1 for NHA) (repair kit available	REF	
-1	83606	.CLEANER SUBASSY, Air (see figure 8-13 for breakdown)	1	
-2	120854	.SCREW, Hex hd, cap, 1/4 -20 x 5/8 (AP)	4	
-3	120380	.LOCK WASHER, 1/4" (AP)	4	
-4	84523	.GASKET, Cleaner hose to head	1	
-5	3462094	.FILTER, Crankcase 12204 (65381)	1	
-6	1B	.HOSE, Crankcase, fltr, 1" ID x 1-3/8" OD x 3" lg (24161)(65624)	1	
-7	66499	.CLAMP, Hose (AP)	2	
-8	65629	.NIPPLE, Pipe, close.....	1	
-9	144113	.ELBOW, Street, 90° 3/4" NPT.....	1	
-10	65622	.DIPSTICK, Oil	1	
-11	28594	.O-RING (77308).....	1	
-12	65623	.GUIDE, Dipstick	1	
-13	144086	.TEE, Pipe, 3/4 NPT (24617)	1	
-14	67870	.NIPPLE, 3/4 NPTx 15 lg.....	1	
-15	65468	.TUBE SUBASSY, Oil pump to oil filter	1	
-16	28837	.CONNECTOR, Straight, 1/4 NPT x 3/8 tube	1	
-17	28843	.ELBOW, Male 90°, 3/8 NPT x 3/8 tube	1	
-18	65470	.TUBE SUBASSY, Oil -filter to oil -pump.....	1	
-19	28837	.CONNECTOR, Straight, 1/4 NPT x 3/8 tube	2	
-20	61073	.HOSE SUBASSY, 3 stg to oil sump	1	
-21	28890	.ELBOW, Male, 90°, 1/4 NPT x 3/8 tube	2	
-22	61074	.HOSE ASSY, 4th stg cyl to oil -sump.....	1	
-23	28892	.TEE, Mole, 1/4 NPT x 3/8 tube.....	1	
-24	38029	.HOSE SUBASSY, 4th stg cyl to oil -sump	1	
-25	82846	.ELBOW AND ORIFICE ASSY	1	
-26	41899	.ELBOW	1	
-27	61075	.HOSE ASSY, Oil -pump to oil sump	1	
-28	28890	.ELBOW, Male 90° 1/4 NPT x 3/8 tube	3	
-29	70541	.WIRE TIE	2	
-30	61076	.HOSE ASSY, Oil sump to oil pump.....	1	
-31	68X6	.CONNECTOR, Straight, 1/4 NPT x 3/8 tube (79470) (28888)	1	
-32	28837	.CONNECTOR, St., 1/4 NPT x 3/8" tube.....	1	
-33	Deleted			
-34	127961	.ELBOW, 1/2 NPT - str 90°	1	
-34a	143935	.PLUG, Square hd 1/2"	1	
-34b	127963	.ELBOW, 90°, 1/2 NPT	1	
-34c	219646	.NIPPLE, 1/2 x 4 -1/2"	1	
-35	67871	.PLUG, Pipe, 1/8 NPT	1	
-36	68X5X4	.CONNECTOR, Straight, 1/4 NPT x 5/16 tube (79740) (66950)	1	
-37	116332	.BUSHING, Rdcr, 3/8 NPT x 1/4 NPT (24617) (61019).....	1	
-38	49551	.PISTON, Valve.....	1	
-39	17331	.SCREW, Relief, oil.....	1	
-40	17330	.LOCKNUT, Relief screw	1	
-41	25047	GASKET, Locknut	1	
-42	17333	.SPRING, Relief	1	
-43	09515	.BALL, Steel 3/8" dia	1	
-44	PER1	.FILTER, Oil (81321) (46704).....	1	
-45	61808	.ADAPTER, Filter to bracket	1	
-46	65500	.BRACKET, Filter mtg	1	
-47	122168	.SCREW, Hex hd, cap, 3/8 -16NC x 1 -3/4" lg (AP) .(24617)	2	
-48	120382	.WASHER, Lock, split, 3/8" (AP) (24617)	2	
-49	No Number	.PISTON GROUP, Cyl hd and 1st stage (see figure 8 -14 for breakdown)	1	
-50	443343	.NUT, Lock, 5/8 - INC (AP) (24617)	4	
-51	45542	.STUD, 5/8 -1 INC	4	
-52	83995	.GASKET, 1 stg cyl to crkc.....	1	
-53	24803	.RING, Retaining.....	2	
-54	No Number	.PISTON GROUP, Cyl hd and 2 stg (see figure 8 -15 for breakdown)	1	
-55	443343	.NUT, Lock, 5/8 -11INC (AP) (24617)	4	
-56	45542	.STUD, 5/8 -1 NC	4	
-57	44844	.GASKET, 2 stg cyl to crkc.....	1	
-58	26858	.RING, Retaining.....	2	
-59	No Number	.PISTON GROUP, Cyl hd and 3 stg (see figure 8 -16 for .breakdown)	1	

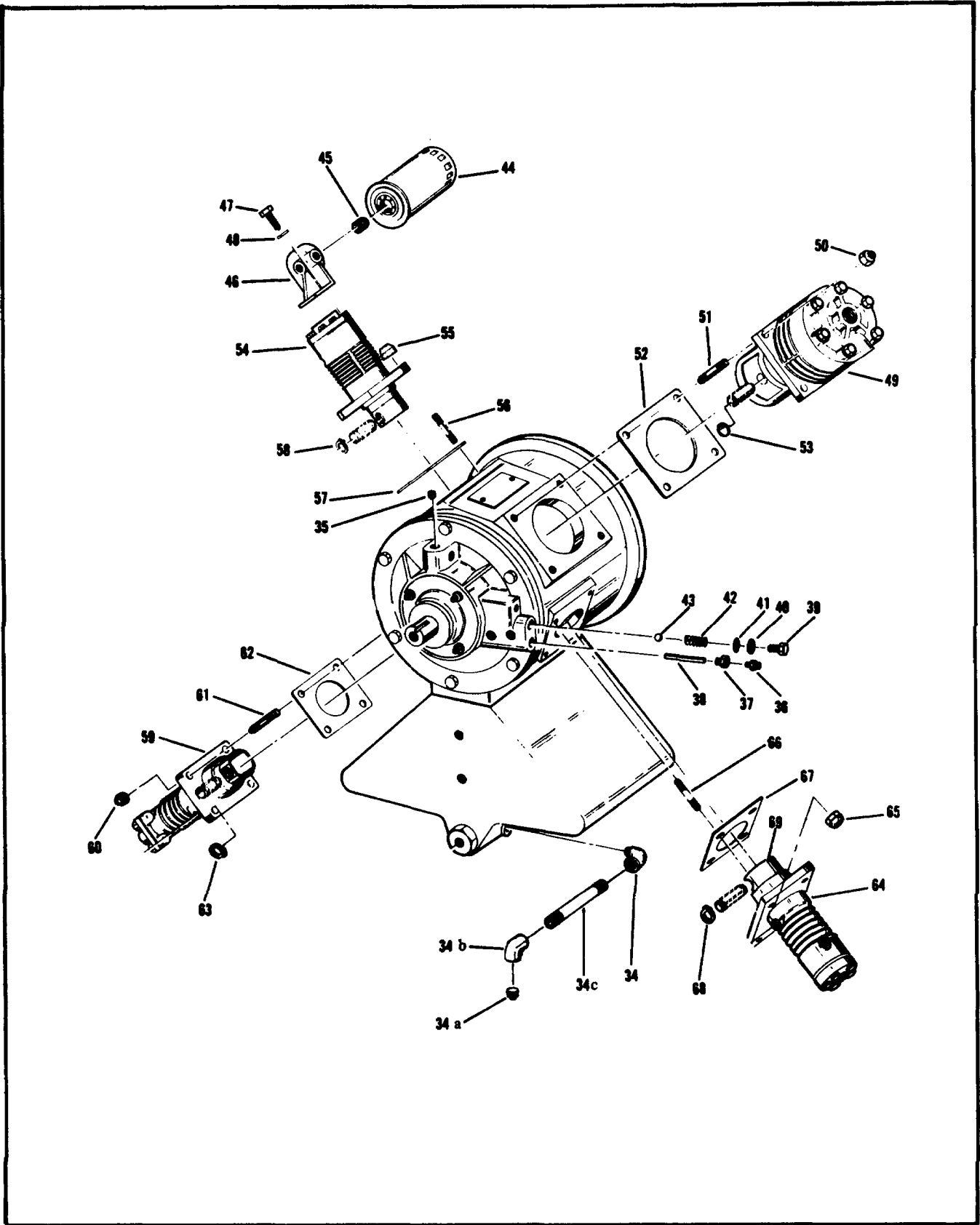

Figure 8-12. Air Compressor Assembly (Sheet 2 of 3)

FIGURE & INDEX NUMBER	PART NUMBER	DESCRIPTION 1 2 3 4 5 6 7	QTY PER ASSY	USABLE ON CODE
-60	443343	.NUT, Lock, 5/8 -11INC (AP) (24617)	4	
-61	45542	.STUD, 5/8 -11NC	4	
42	44844	†.GASKET, 3 stg cyl to crkc.....	1	
-63	26858	.RING, Retaining.....	2	
-44	No Number	.HEAD GROUP, Cyl 4 stg (see figure 8 -17 for breakdown)	1	
-65	443343	.NUT, Lock, 5/8 -11NC (AP) (24617)	4	
-66	45542	.STUD, 5/8 -1 INC	4	
-67	44844	.GASKET, 4 stg cyl to crkc.....	1	
-68	26858	.RING, Retaining.....	2	
-69	45038	.PISTON ASSY 4 stg (see figure 8 -18 for breakdown)	1	
-70	6939	.RING, Drive, clutch (90192) (30859).....	1	
-71	122027	.SCREW, Cap, hex hd 5/16 -18NC x 1 ... -1/4" (AP)(24617)	6	
-72	120214	.LOCK WASHER, Split 5/16 (AP) (24617)	6	
-73	65155	.FLYWHEEL, Crankshaft	1	
-74	9421705	.SCREW, Cap, sk hd 5/16 -18NC x 3/4 in. lg (AP) (24617)	3	
-75	28147	.WASHER, Lock, split, 5/16 (24617)	3	
-76	29510	.PIN, Dowel, flywheel	3	
-77	45003	.GASKET, Flywheel	1	
-78	45012	.COVER, Oil seal	1	
-79	21FAF518	.NUT, Lock, 5/16 -18NC (AP) (56878) (65872)	4	
-80	49264	.WASHER, Seal (AP)	4	
-81	24500	.O-RING (77308).....	1	
-82	43398	†.SEAL, Oil	1	
-83	45010	.COVER, Outer pump	1	
-84	82685	.COVER, End.....	1	
-85	120233	.SCREW, Cap, hex hd, 3/8 -16NC x 1 in. lg (AP)(24617) ..	6	
-86	120382	.WASHER, Lock, split 3/8 (AP) (24617)	5	
-87	Deleted			
-88	44534	.WASHER, Seal	1	
-89	45028	†.GASKET, End cover	1	
-90	49567	.BUSHING	2	
-91	24498	†.O-RING	1	
-92	45018	.ROTOR, Oil pump.....	1	
-93	45019	.BLADE, Oil pump.....	4	
-94	45543	.KEY, Rotor, oil pump.....	1	
-95	65152	.COVER, Inner	1	
-96	65160	.STUD, Cover, pump 5/16 18NC x 2 -1/2 in lg.....	4	
-97	63X643	.SEAL, Oil (73680) (24501).....	1	
-98	45015	.COVER, Drive -end.....	1	
-99	120918	.SCREW, Cap, hex hd, 3/8 -16NC x 1 -1/2 in. lg (AP) (24617)	5	
-100	120382	.LOCK WASHER 3/8 (AP) (24617)	5	
-101	122145	.SCREW, Cap, hex hd, 3/8 -16NC x 1 -1/4 in. lg (AP) (24617)	1	
-102	44534	.WASHER, Seal	1	
-103	45028	†.GASKET, Cover, drive end	1	
-104	63X2037	†.SEAL, Oil (73680) (45017).....	1	
-105	311K	.BEARING, Crankshaft (21335) (11068)	2	
-106	65153	.WEIGHT, Balance.....	2	
-107	179146	.SCREW, Cap, skt hd, 3/8 -16NC x 1 -1/4 in. lg (24617) .4		
-108	120382	.WASHER, Lock, 3/8 in (24617)	4	
-109	46514	.ROD SUBASSY, Connecting	1	
	GB16160H	.. BEARING, Piston pin (80657) (46513)	1	
	44809	.. ROD CONNECTING.....	1	
-110	46541	.. ROD ASSY, Connecting	1	
	GB16160H	.. BEARING, Piston pin (80657) (46513)	1	
	44808	.BEARING, Crankshaft.....	1	
-111	44819	.ROD ASSY, Connecting	1	
	28441	.BEARING, Piston pin	1	
	44809	.BEARING, Crankshaft	1	
	44820	.ROD, Connecting	1	
-112	65151	.CRANKSHAFT	1	
-113	67871	.PLUG, Skthd 1/8NPT	1	

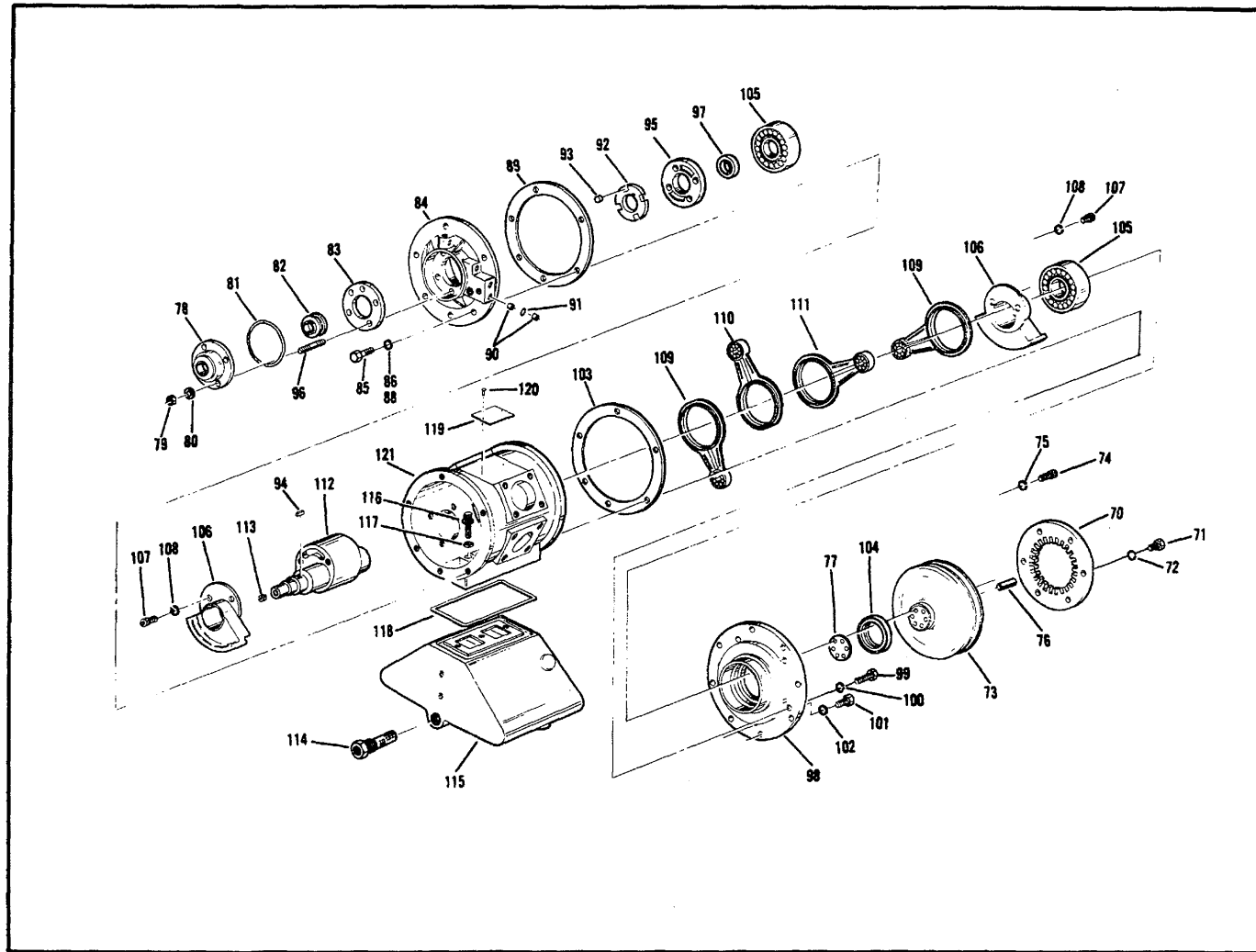

Figure 8-12. Air Compressor Assembly (Sheet 3 of 3)

FIGURE & INDEX NUMBER	PART NUMBER	DESCRIPTION							QTY PER ASSY	USABLE ON CODE
		1	2	3	4	5	6	7		
-114	19189	.STRAINER, Oil.....							1	
-115	65181	.SUMP, Oil							1	
-116	49263	.SCREW, Cap, 12 pt hd, ½ -13NC x 1 -1/4 in. lg (AP)							3	
-117	120384	.WASHER, Lock, spit 1/2 (AP)(24617)							3	
-118	45027	.PACKING, Preformed o -ring							1	
-119	41180	.PLATE, Serial number.....							1	
-120	9426053	.SCREW, Siftpg no 440 x 1/4 (AP) (24617)							2	
-121	83994	.CRANKCASE, Compressor							1	
	84949	.REPAIR KIT, Overhaul, compressor							REF	
8-28										

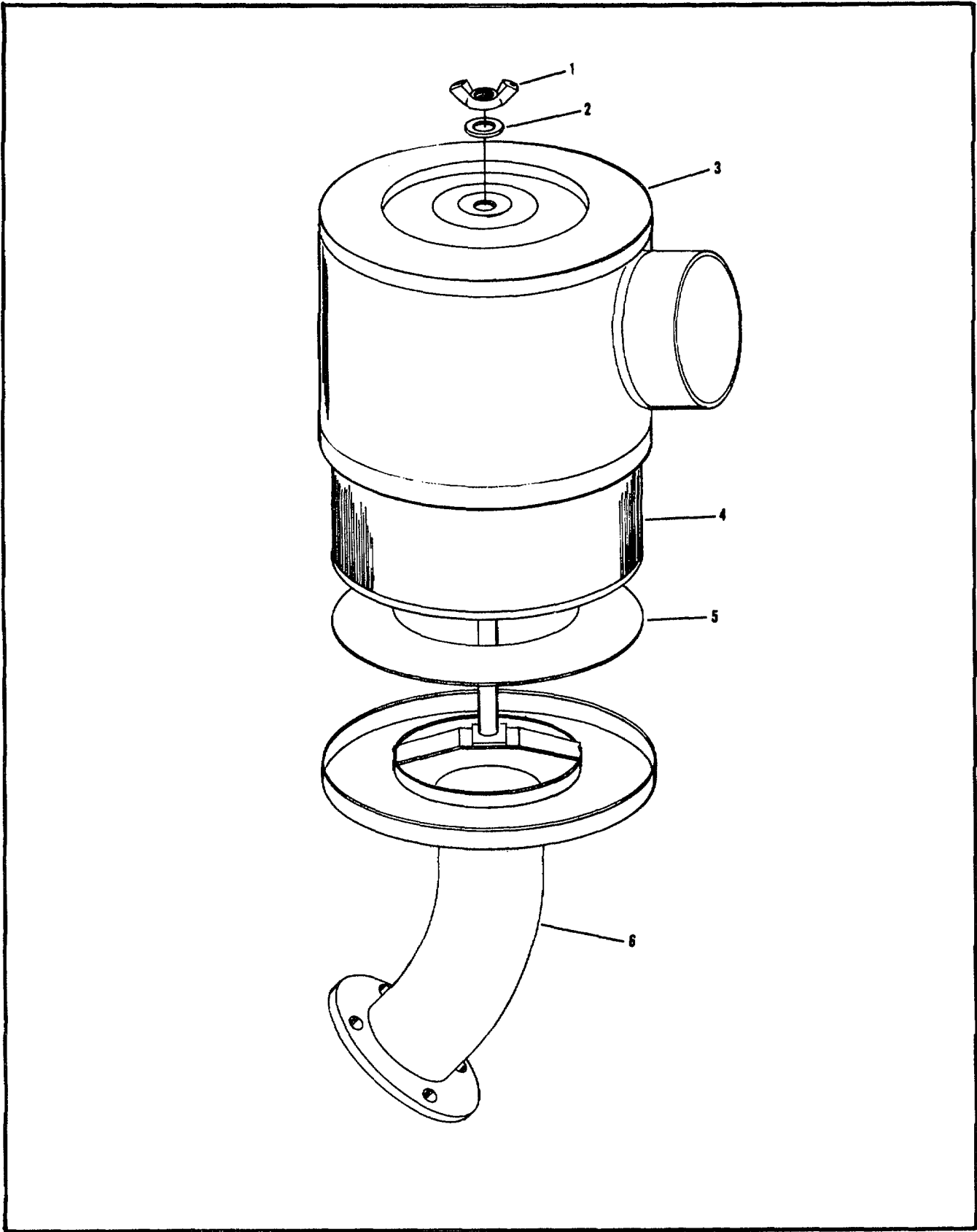

Figure 8-13. Air Cleaner Assembly

FIGURE & INDEX NUMBER	PART NUMBER	DESCRIPTION							QTY PER ASSY	USABLE ON CODE
		1	2	3	4	5	6	7		
8-13	83606	CLEANER ASSY, Air (see figure 8 -12 for NHA)							REF	
-1	84807	.NUT, Wing, ¼ -20 (AP)							1	
-2	84808	.WASHER (AP)							1	
-3	84809	.COVER, Cleaner, air							1	
-4	27248	.ELEMENT							1	
-5	83352	.GASKET							1	
-6	84810	.BASE ASSY							1	
8-30										

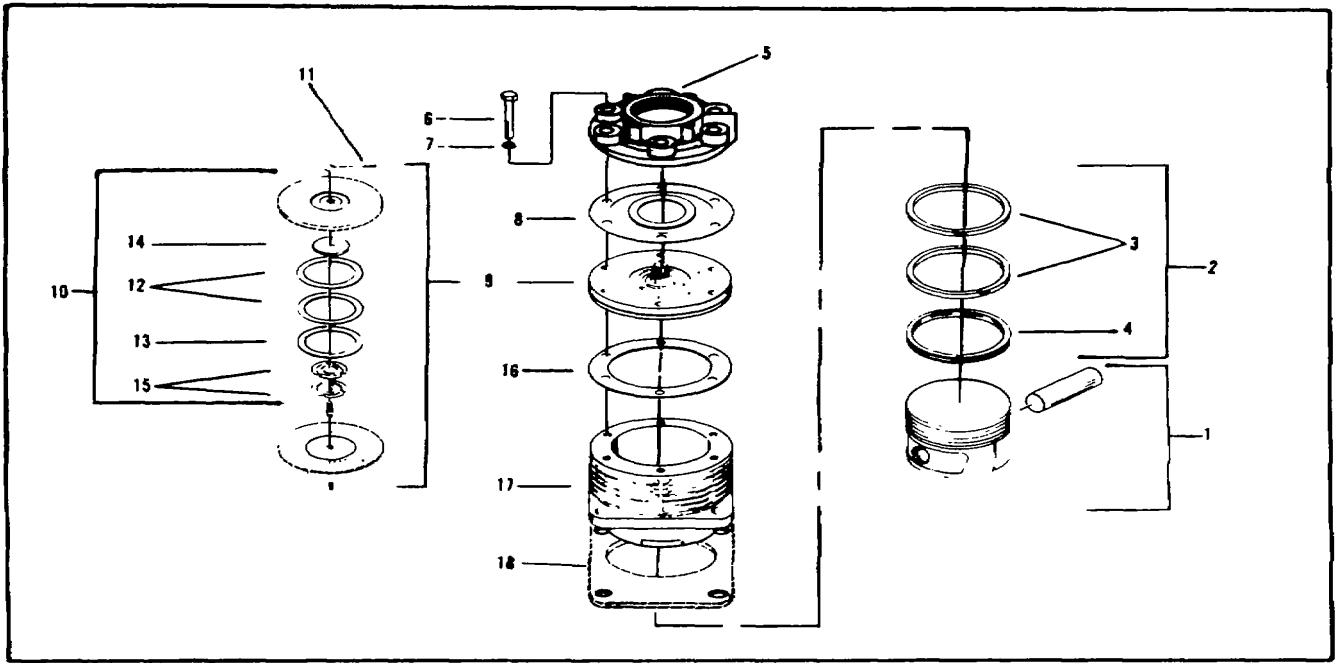

Figure 8-14. First Stage Head, Cylinder, and Piston Group

FIGURE & INDEX NUMBER	PART NUMBER	DESCRIPTION	UNITS PER ASSY							USABLE ON CODE	
			1	2	3	4	5	6	7		
8-14	No Number	FIRST STAGE CYLINDER AND PISTON GROUP								REF	
		(See figure 8-12 for NHA) (repair kit available)									
-1	83605	PISTON AND PIN ASSY								1	
-2	84804	RING KIT, First stage								1	
-3	†83232	RING, Compression								2	
-4	†83233	RING, Oil control								1	
-5	83229	HEAD, Cylinder, 1st stage								1	
-6	122188	SCREW, Cap, hex hd, 3/8-16NC x 2-1/4 in lg (AP)								6	
-7	120382	WASHER, Lock, split, 3/8 m (AP)								6	
-8	††84503 G	ASKET, Cylinder head								1	
-9	83231	VALVE ASSEMBLY, First stage (repair kit available)								1	
-10	†84805	KIT, Repair, first stage valve								AR	
-11	2X16-250048	PIN, Cotter (24643)-								1	
-12	104CD43056623	SPRING, Lentoid (24643).....								2	
-13	104CD-40-056622	RING, Valve (24643).....								1	
-14	60R240-051847	PLATE, Valve (24693).....								1	
-15	60R241-051872	PLATE, Spring(24643)								2	
-16	††84502	GASKET, Valve								1	
-17	83228	CYLINDER, First stage								1	
-18	††83233	GASKET, Cylinder (see figure 7-12-54 for NHA)								REF	
	84806	KIT, Repair, first stage cylinder group								AR	
		†Component of kit 84806									
		††Component of kit 84806 and 84949									

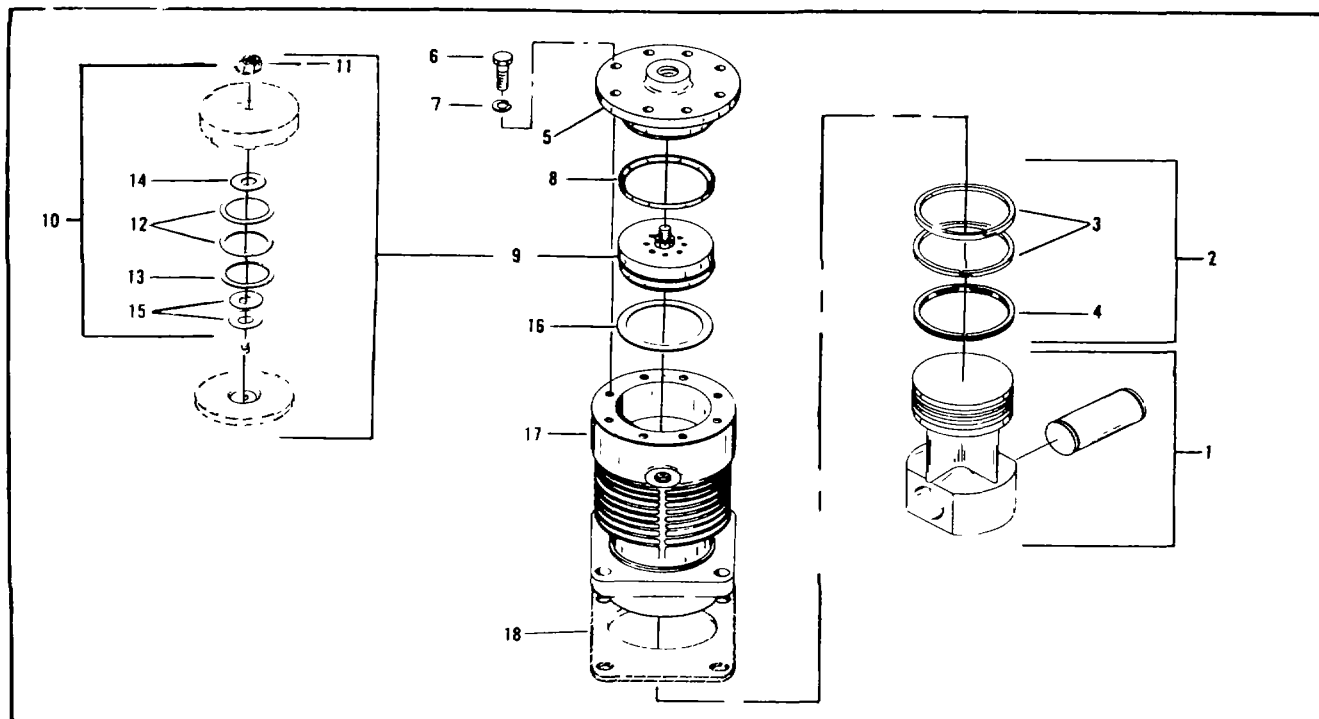

Figure 8-15. Second Stage Head, Cylinder, and Piston Group

FIGURE & INDEX NUMBER	PART NUMBER	DESCRIPTION	UNITS PER ASSY							USABLE ON CODE	
			1	2	3	4	5	6	7		
8-15	No Number	SECOND STAGE CYLINDER AND PISTON GROUP								REF	
		(See figure 8-12 for NHA) (repair kit available)									
-1	46062	PISTON AND PIN ASSEMBLY								1	
-2	65885	RING KIT, Second stage								1	
-3	†44806	RING, Compression								2	
-4	†44807	RING, Oil control								1	
-5	44843	HEAD, Cylinder								1	
-6	122145	SCREW, Cap, hex hd, 3/8-16NC x 1-1/4 in lg (AP)								6	
-7	120382	WASHER, Lock, split, 3/8 in (AP)								6	
-8	††44845	GASKET, Cylinder head								1	
-9	45033	VALVE ASSEMBLY, Second stage (repair kit available)								1	
-10	†66495	KIT, Repair, second stage valve								AR	
-11	30-5/64X7/8	PIN, Cotter (24643)								1	
-12	62C-41-035458	SPRING, Lentoid (24643)								2	
-13	62C-40-035457	RING, Valve (24643)								1	
-14	30R1-50-035441	RING, Valve (24643)								1	
-15	30R1-52-026273	SPRING, Lentoid (24643)								2	
-16	tt44846	GASKET, Valve								1	
-17	44842	CYLINDER, Second stage								1	
-18	†44844	GASKET, Cylinder (see figure 7-12-59 for NHA)								REF	
	68510	KIT, Repair, second stage cylinder group								AR	
		†Component of kit 68510									
		††Component kit 68510 and 84949									

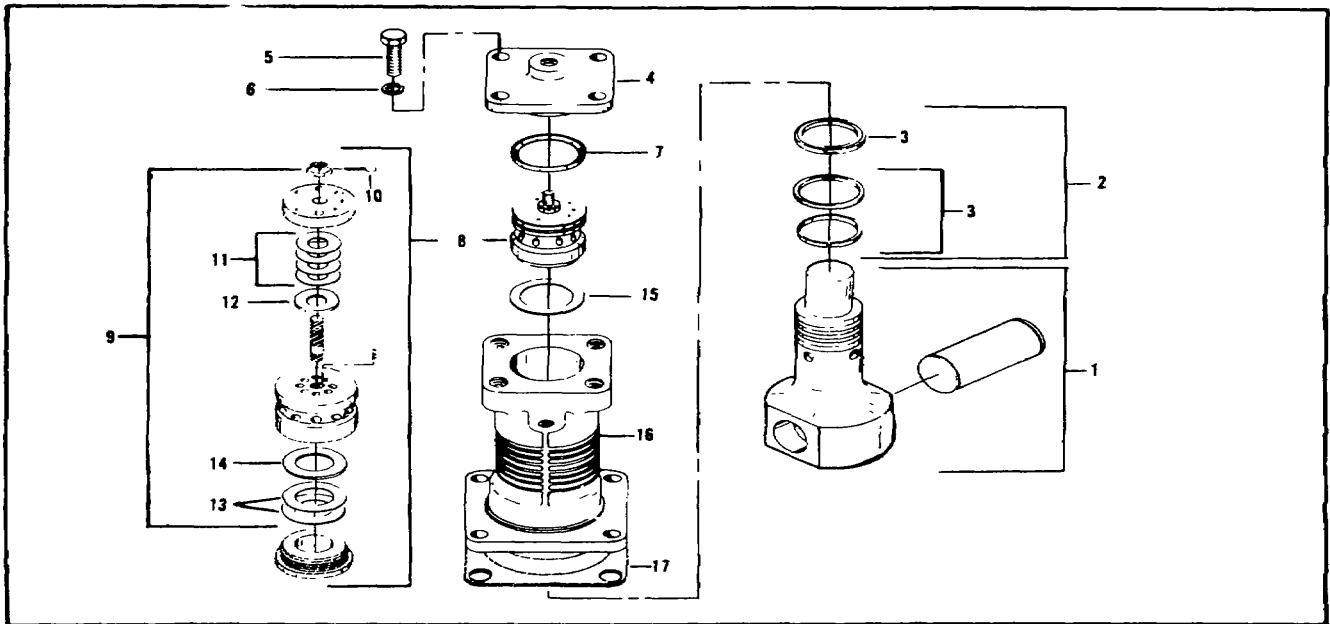

Figure 8-16. Third Stage Head, Cylinder, and Piston Group

FIGURE & INDEX NUMBER	PART NUMBER	DESCRIPTION	UNITS PER ASSY							USABLE ON CODE	
			1	2	3	4	5	6	7		
8-16	No Number	THIRD STAGE CYLINDER AND PISTON GROUP..... (See figure 8-12 for NHA) (repair kit available)								REF	
-1	46063	PISTON AND PIN ASSEMBLY								1	
-2	65886	RING KIT, Piston, 3rd stage								1	
-3	†28442	RING ASSEMBLY, Piston								3	
4	44840	HEAD, Cylinder, third stage.....								1	
-5	122433	SCREW, Cap, hex hd, 1/2-13NCx 1-1/2 in lg (A)								4	
-6	120384	WASHER, Lock, split, 1/2 in (AP)								4	
-7	††28339	GASKET, Cylinder head.....								1	
-8	28155	VALVE ASSEMBLY, Third stage (repair kit available).....								1	
-9	†66492	KIT, Repair, third stage valve								AR	
-10	50-5/64x5/8	PIN, Cotter (24643)								1	
-11	30R1-52-026273	SPRING, Lentoid (24643).....								4	
-12	30R-40-035441	RING, Valve (24643).....								1	
-13	41-035448	SPRING, Lentoid (24643).....								2	
-14	40-035447	RING, Valve (24643).....								1	
-15	††28350	GASKET, Valve								1	
-16	44839	CYLINDER, Third stage								1	
-17	††44844	GASKET, Cylinder (see figure 7-12-64 for NHA).....								REF	
	68511	KIT, Repair, third stage cylinder group								AR	
		†Component of kit 68511									
		††Component of kit 68511 and 84949									

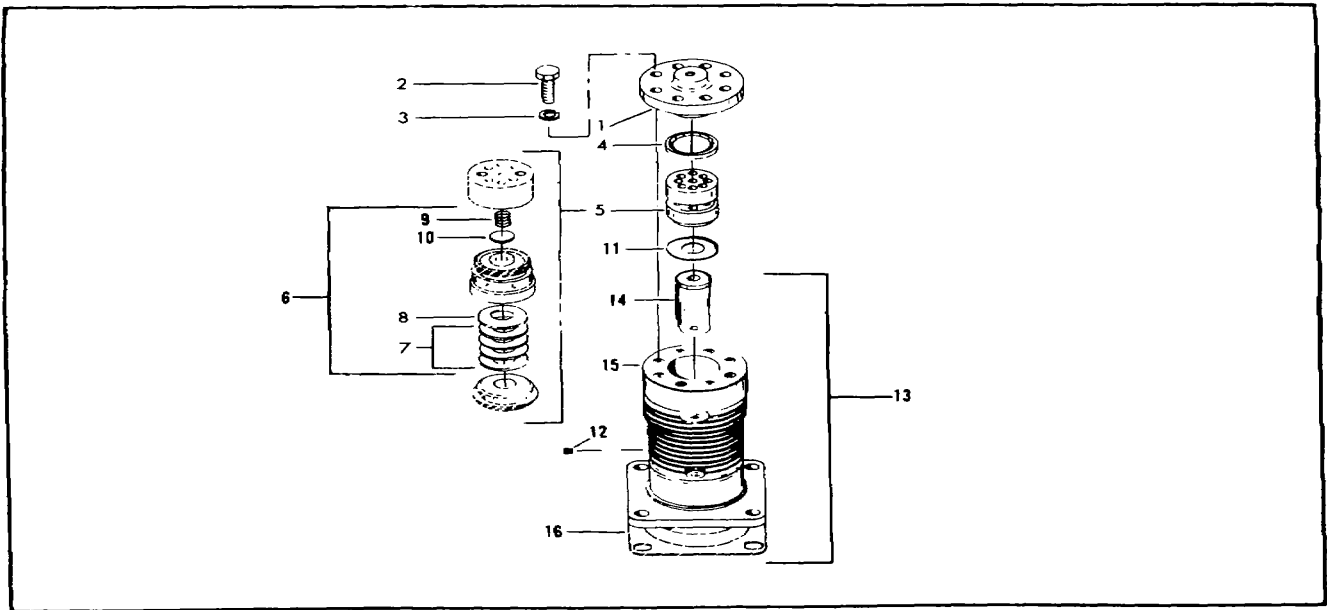

Figure 8-17. Fourth Stage Head and Cylinder Group

FIGURE & INDEX NUMBER	PART NUMBER	DESCRIPTION							UNITS PER ASSY	USABLE ON CODE
		1	2	3	4	5	6	7		
8-17	No Number	FOURTH STAGE CYLINDER GROUP (See figure 8-12 for NHA) (repair kit available)							REF	
-1	44838	HEAD, Cylinder, fourth stage							1	
-2	122433	SCREW, Cap, hex hd, 1/2-13NC x 1-1/2 in lg (AP)							8	
-3	120384	WASHER, Lock, split, 1/2 in (AP)							8	
A	††28340	GASKET, Cylinder head							1	
-5	28156	VALVE ASSEMBLY, Fourth stage (repair kit available)							1	
-6	†66493	KIT, Repair, fourth stage valve							AR	
-7	30R1-52-026273	SPRING, Lentiod (24643)							4	
-8	30R40-035441	RING, Valve (24643)							1	
-9	60-1210	SPRING, Closing (24643)							1	
-10	40-035442	DISC, Valve (24643)							1	
-11	††28349	GASKET, Valve							1	
-12	144011	PLUG, Pipe, steel, sch, 1/4 NPT							2	
-13	45222	CYLINDER ASSEMBLY, Fourth stage							1	
-14	44835	LINER, Cylinder							1	
-15	44837	CYLINDER							1	
-16	††44844	GASKET, Cylinder, fourth stage (see figure 7-12-69 for NHA)							REF	
	68512	KIT, Repair, fourth stage cylinder and piston group							AR	
		†Component of kit 68512								
		††Component of kit 68512 and 84949								

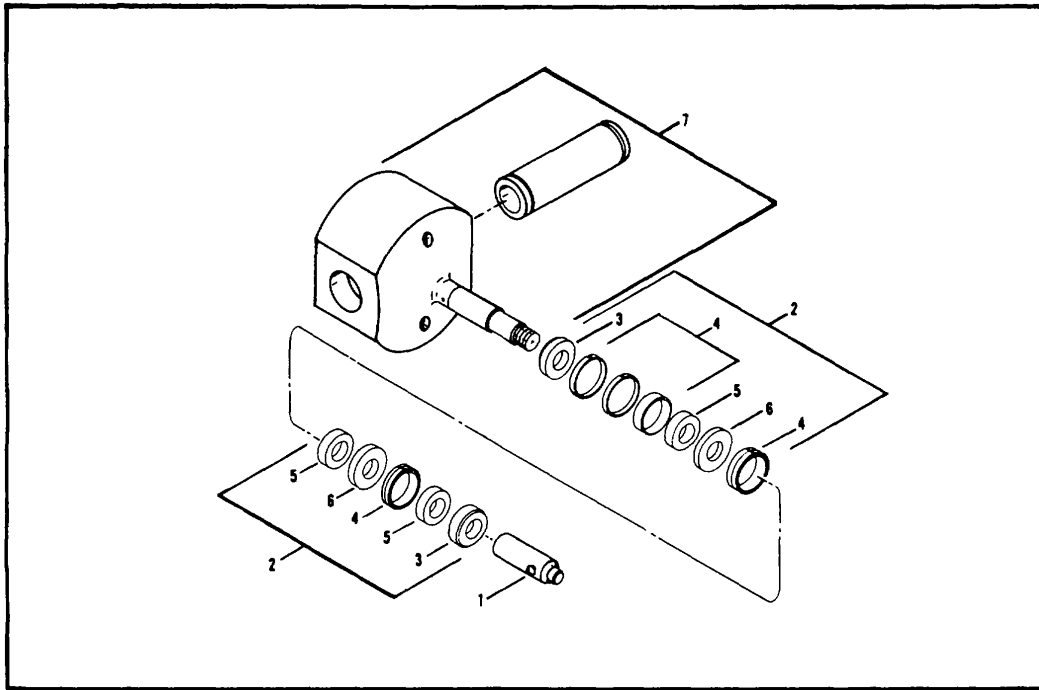

Figure 8-18. Fourth Stage Piston Assembly

FIGURE & INDEX NUMBER	PART NUMBER	DESCRIPTION	UNITS PER ASSY	USABLE ON CODE
		1 2 3 4 5 6 7		
8-18	45038-1	FOURTH STAGE PISTON ASSEMBLY..... (see figure 8-17 for NHA) (repair kit available)	REF	
-1	83092	NUT, Stem.....	1	
-2	65887	RING KIT, Fourth stage.....	1	
-3	†45037	RING, Locator.....	2	
4	†28443	RING ASSEMBLY.....	3	
-5	†28679	SPACER, Ring.....	3	
-6	†45041	RING, Separator.....	2	
-7	83091	PISTON AND PIN ASSEMBLY.....	1	
		†component of kit 68512		

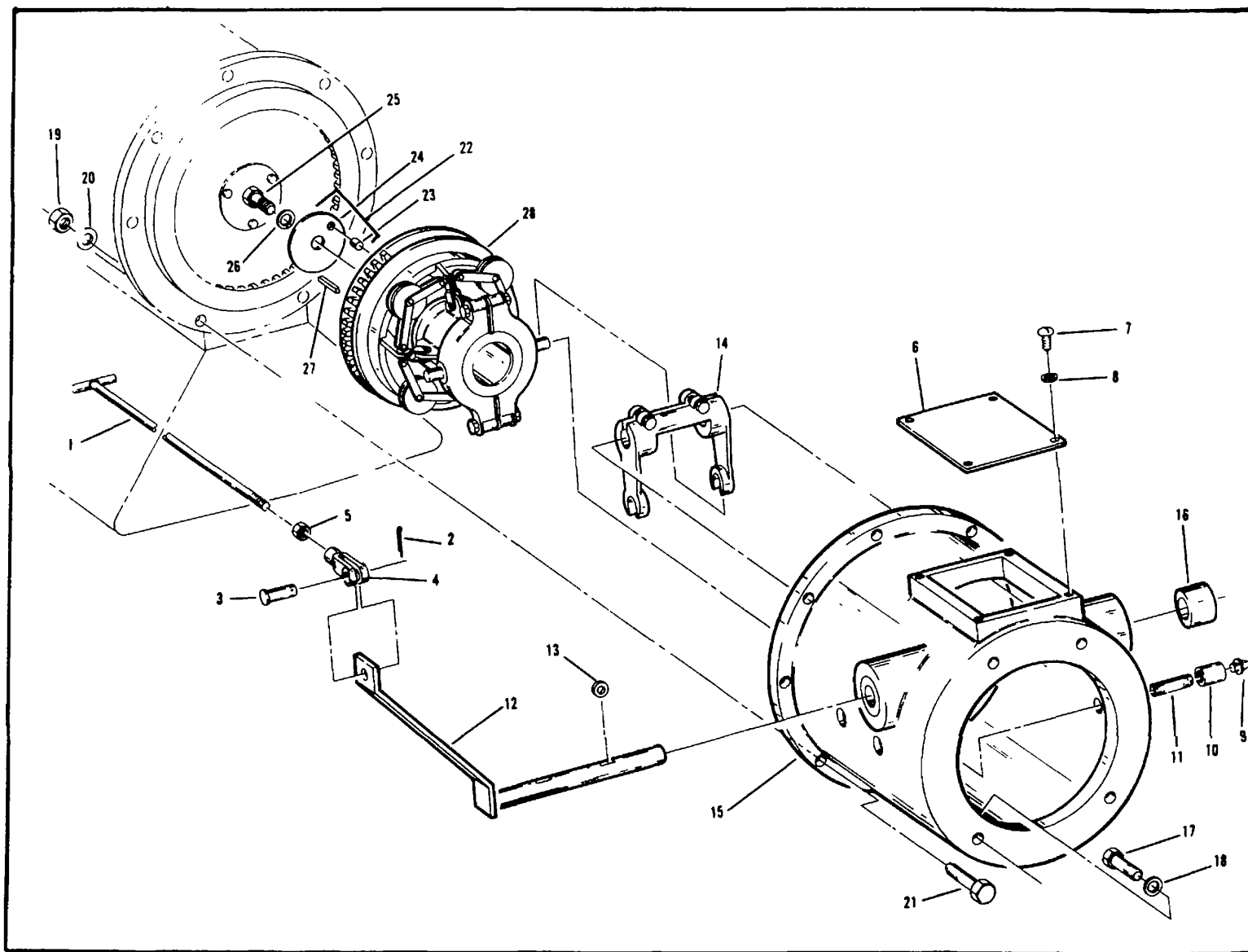

Figure 8-19. Clutch and Housing Group (Sheet 1 of 2)

FIGURE & INDEX NUMBER	PART NUMBER	DESCRIPTION							UNITS PER ASSY	USABLE ON CODE
		1	2	3	4	5	6	7		
8-19	No Number	CLUTCH AND HOUSING GROUP (See figure 8-1 for NHA).....							REF	
-1	29561	ROD, Clutch 1								
-2	121224	PIN, Cotter, 3/32x 1(24617).....							1	
-3	10165	PIN, Clevis- -.....							1	
-4	11014	CLEVIS							1	
-5	120396	NUT, Jam, 3/8-24 (24617).....							1	
-6	46045	COVER, Hand hold.....							1	
-7	120217	WASHER, Lock, split no 10 (24617)							4	
-8	120221	SCREW, Mach. rd hd no 10-24NC (24617).....							4	
-9	14021	FITTING, Lubrication.....							1	
-10	144067	COUPLING, 1/8 (24617) .I.--.....							1	
-11	192043	NIPPLE, 1/8 x 2" (24617).....							1	
-12	65497	SHAFT ASSY, Clutch and lever							1	
-13	29382	KEY, Yoke - -								2
-14	29381	YOKE, Clutch throwout							1	
-15	65479	HOUSING ASSY, Clutch.....							1	
-16	AA1213-12	BUSHING, Clutch housing(70147)							2	
-17	122279	SCREW, Hex hd 7/16-14 x 1-1/2 (24617).....							4	
-18	120383	WASHER, Lock, split, 7/16 (24617)							4	
-19	120377	NUT, Hex, 3/8-16 (24617).....							8	
-20	120382	WASHER, Lock, spit, 3/8 (24617).....							8	
-21	120918	SCREW, Hex hd, 3/8-16 x 1-1/2 (24617).....							8	
-22	66376	WASHER ASSY, Clutch							1	
-23	65867	PIN							1	
-24	66375	WASHER, Clutch							1	
-25	428211	SCREW, Hex hd, 5/8-11NCx 1-1/4 lg (24617).....							1	
-26	121574	WASHER, Lock, spit 5/8 (24617) -							1	
-27	08178	KEY, Woodruff, 1/4 x 1" l& no 15							1	
-28	66500	CLUTCH ASSY							1	
-29	X117C-8	COLLAR SUBASSY, Clutch (90192).....							1	
-30	M1930F	NUT, Hex, plain (90192).....							2	
-31	M200OZ BB	Screw, Cap hex hd (90192).....							2	
-32	12OC-8	SPACER, Collar (90192).....							2	
-33	117C-8	COLLAR, Clutch (90192)							1	
-34	112726	PIN, Cotter (24617)							12	
-35	67960	PIN, Clevis12								
-36	67089	WEIGHTS, Washer							12	
-37	67090	LINK, Weight (NPS)							16	
-38	67091	PIN, Link (NPS).....							4	
-39	2969	SLEEVE, Sliding (90192)							1	
-40	B1535B	PIN, Cotter (90192).....							4	
41	B1537C	PIN, Clevis (90192).....							4	
-42	2968	LINK, Lever (90192).....							8	
43	B1535B	PIN, Cotter (90192).....							4	
-44	B1537A	PIN,Clevis(90192)							4	
45	2411	LEVER, Finger (90192).....							4	
46	2042	PIN, Locking (90192)							1	
-47	1382	SPRING, Pi, lock (90192).....							1	
48	3206	YOKE, Adjusting (90192)							1	
49	3951	PLATE, Floating (90192).....							1	
-50	A-3507-S	PLATE, Driving (90192) (67974)							1	
-51	A2286	SPRING, Release (90192).....							6	
-52	1100-3	PIN, Plate (90192).....							1	
-53	A-3024	HUB, Subassy (90192).....								

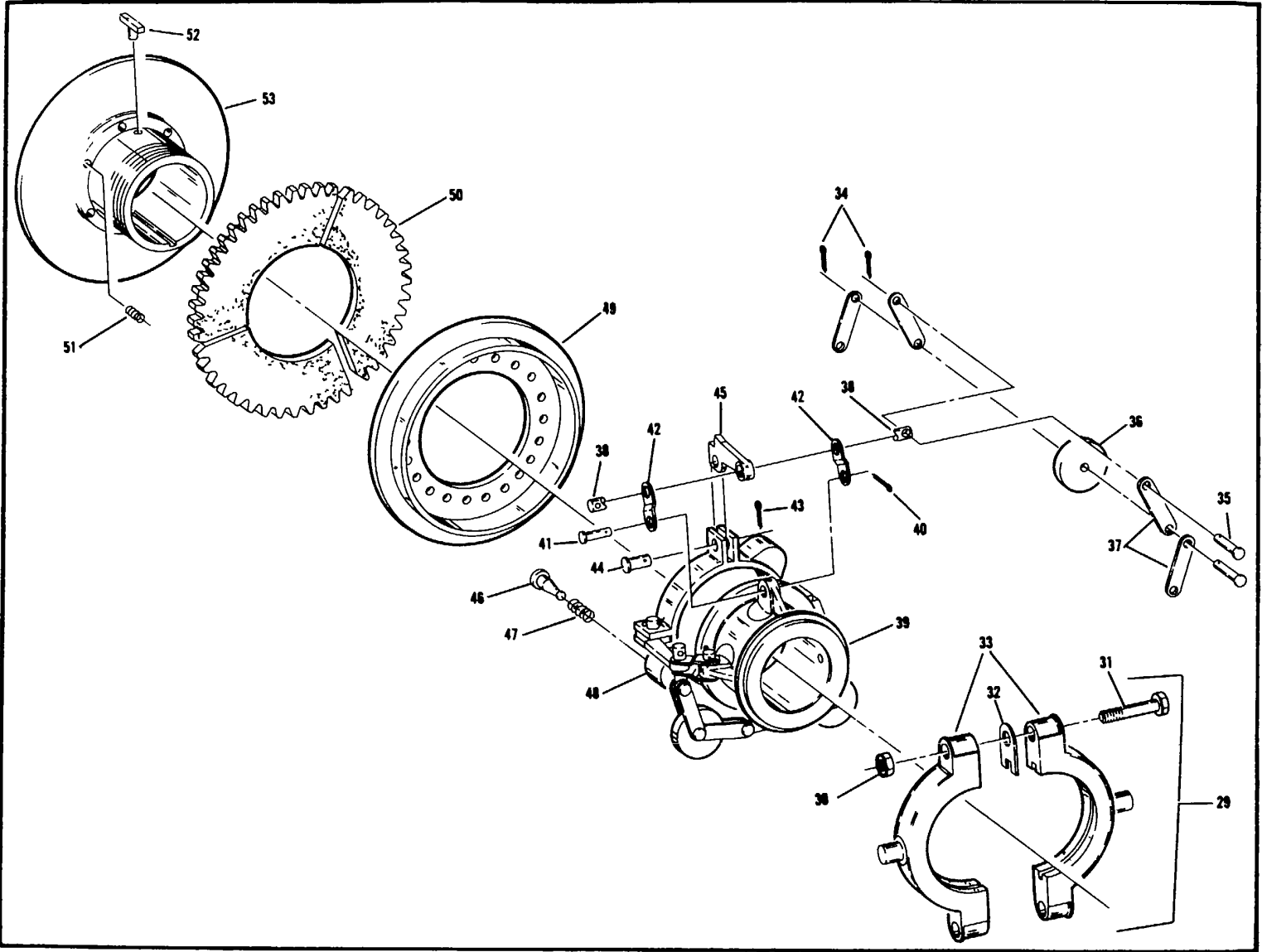

Figure 8-19: Clutch and Housing Group (Sheet 2 of 2)

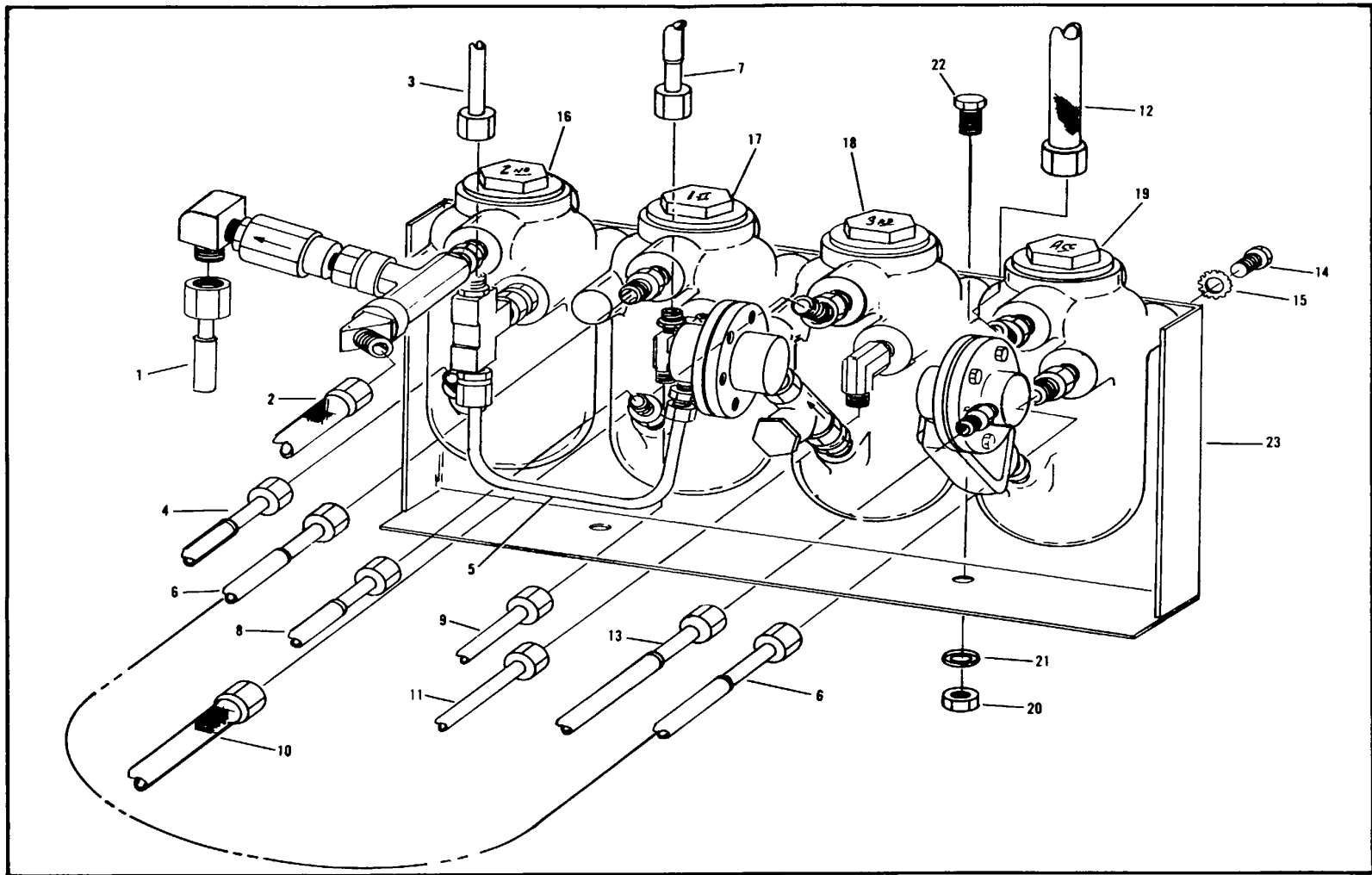

Figure 8-20. Trap and Accumulator Group.

FIGURE & INDEX NUMBER	PART NUMBER	DESCRIPTION							UNITS PER ASSY	USABLE ON CODE
		1	2	3	4	5	6	7		
8-20	No Number	TRAP AND ACCUMULATOR ASSY GROUP (see figure 8-1 for NHA)							REF	
-1	45332	HOSE ASSY, 2nd stg trap to sol valve							1	
-2	69748	HOSE ASSY, Flex, to 3rd stg cyl.....							1	
-3	84881	TUBE ASSY, 2nd stg cooler to 2nd stg trap							1	
-4	44361	HOSE ASSY, to 2nd stg bid valve							1	
-5	84896	TUBE ASSY, 2nd stg cooler to 2nd stg trap							1	
-6	84886	HOSE ASSY, to 1st stg bid valve							1	
-7	45331	TUBE ASSY, 2nd stg trap to 3rd stg trap bleed valve.....							1	
-8	44361	HOSE ASSY, 1st stg trap to accumulator							1	
-9	84873	HOSE ASSY, 1st stg trap to 2nd stg bid valve							1	
-10	69748	HOSE ASSY, 2nd stg trap to 2nd stg bid valve							1	
-11	84874	TUBE ASSY, 1st stg cooler outlet to 1st stg trap							1	
-12	69750	HOSE ASSY, Flex, 3rd stg trap to union							1	
-13	84898	HOSE ASSY, to condensate rec drain line tee							1	
-14	122007	SCREW, Hex hd 5/16-18 x 3/4 (24617).....							8	
-16	69792	TRAP, 2nd stage (see figure 8-22).....							1	
-17	81606	TRAP, 1st stage (see figure 8-21)							1	
-18	69793	TRAP, 3rd stage (see figure 8-23).....							1	
-19	84539	ACCUMULATOR (See figure 8-24).....							1	
-20	443335	NUT, Lock, 3/8-16 (24617)							2	
-21	120394	WASHER, Flat, 3/8 (24617)							2	
-22	120233	SCREW, Hex hd, 3/8-16 x 1" (24617)							2	
-23	83337	BRACKET, Mounting.....							1	

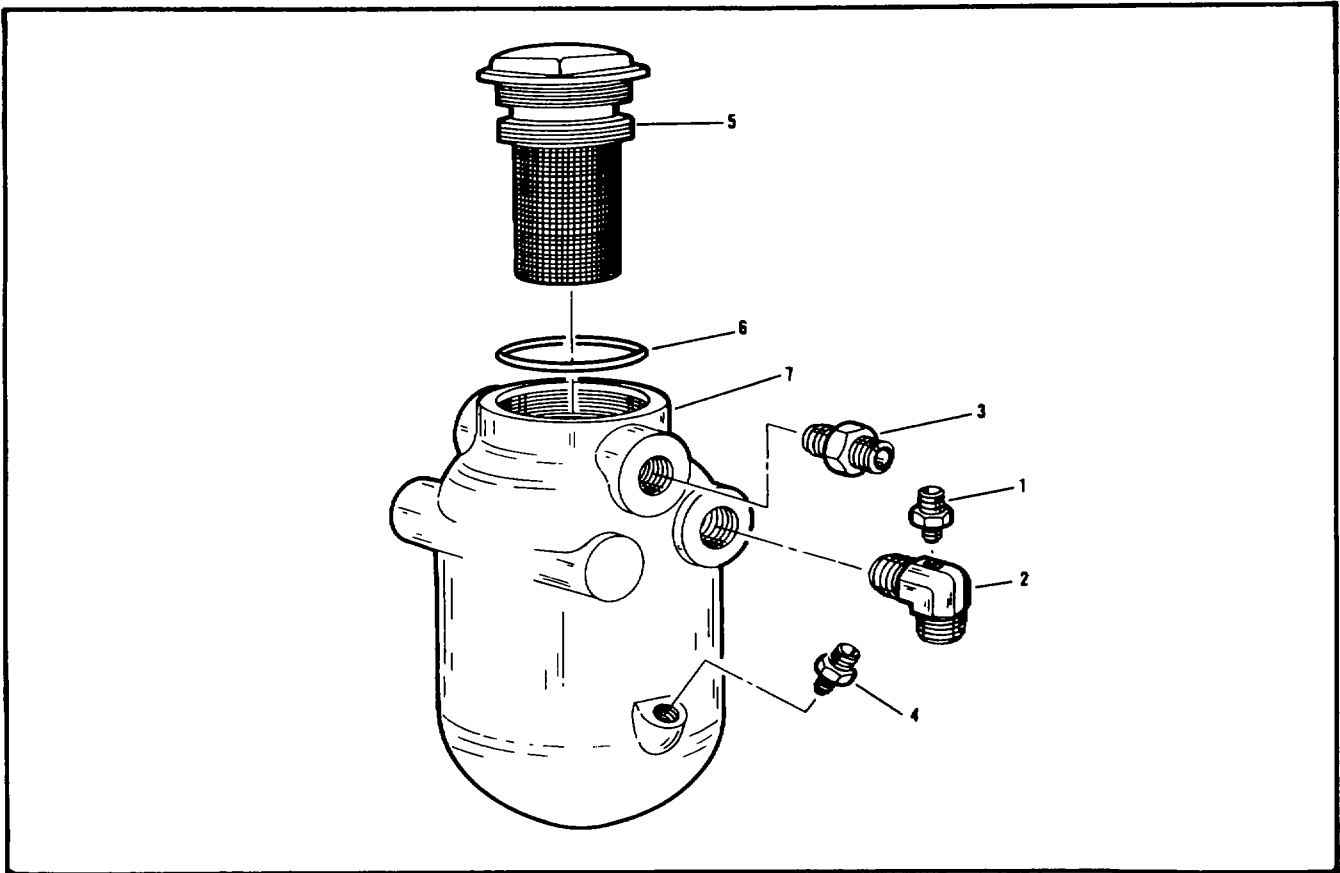

Figure 8-21. First Stage Trap Assembly

FIGURE & INDEX NUMBER	PART NUMBER	DESCRIPTION	UNITS PER ASSY	USABLE ON CODE
		1 2 3 4 5 6 7		
8-21	81606	TRAP ASSY, First stage (see Figure 8-20 for NHA)	REF	
-1	B68X5	ADAPTER, Straight, 1/8NPT x 5/16 tube (79470) (41935)	1	
-2	66275	ELBOW, Male, 90 deg, 3/8NPT x 1/2 tube x 1/8NPT	1	
-3	44291	ADAPTER, Straight, 3/8NPT x 3/8 tube	1	
4	B68X5	ADAPTER, Straight, 1/8NPT x 5/16 tube (79470) (41935)	1	
-5	28727	FILTER SUBASSY, Trap	1	
	28726	SCREEN, Filter	1	
	28725	SCREW, Filter	1	
-6	24978	PACKING, Preformed, O-ring (77308)	1	
-7	65159	BODY, Trap	1	

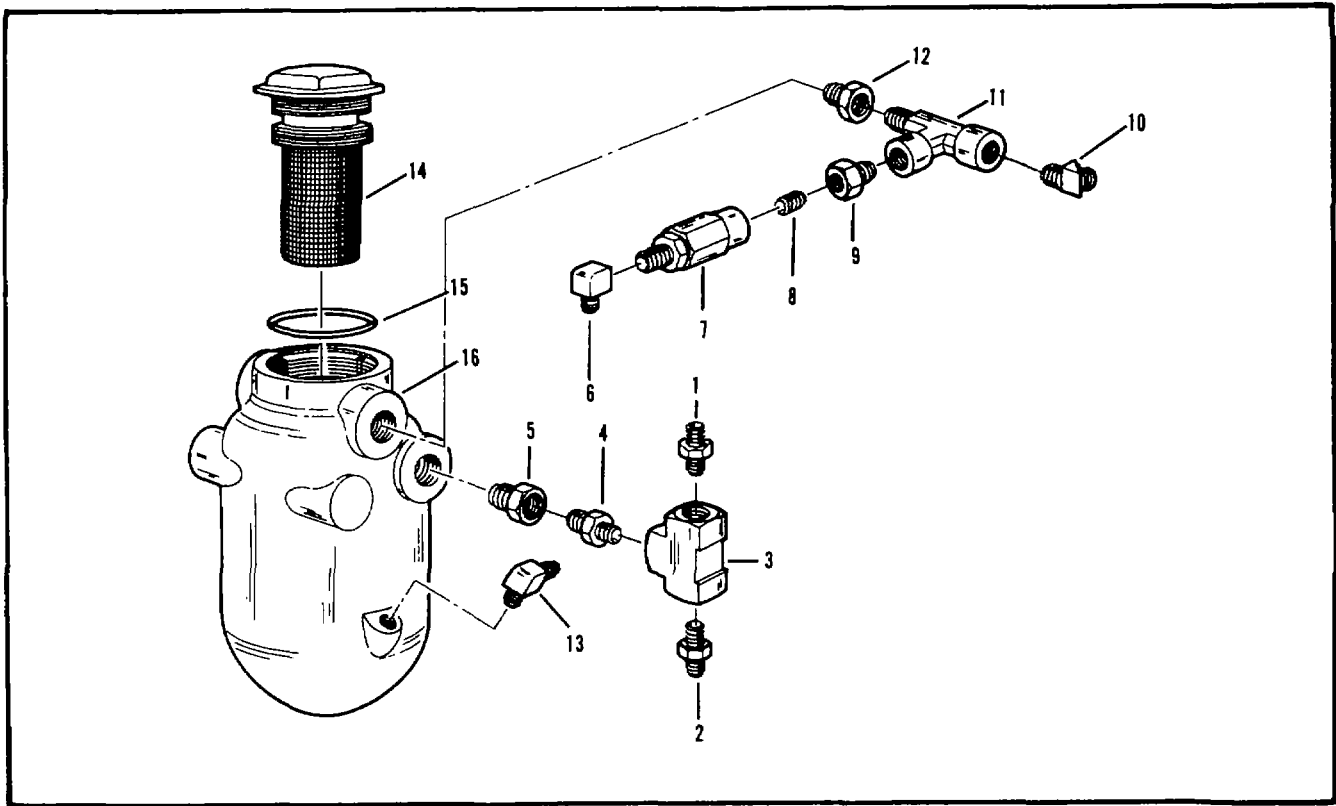

Figure 8-22. Second Stage Trap Assembly

FIGURE & INDEX NUMBER	PART NUMBER	DESCRIPTION	UNITS PER ASSY	USABLE ON CODE
8-22	69792	TRAP ASSY, Second stage (see Figure 8-20 for NHA).....	REF	
-1	28837	ADAPTER, Straight, 1/4NPT x 3/8 tube	1	
-2	28836	ADAPTER, Straight, 1/4NPT x 1/4 tube	1	
-3	3700X4	TEE, Pipe, 1/4NPT (79470) (49916).....	1	
4	Pl:10-4	NIPPLE, Pipe, hex, 1/4NPT (98660) (65610)	1	
-5	116332	BUSHING, Rdcr, 3/8NPTx 1/4NPT(24617).....	1	
-6	70X5	ELBOW, Female, 90 deg1/8NPT x 5/16 tube (79470) (41909)	1	
-7	6133E2S	VALVE, Check, 6,000 psi (28968) (45940).....	1	
-8	192032	NIPPLE, Pipe, close, 1/8NPT (24617).....	1	
-9	3220X4X2	BUSHING, Rdcr, 1/4NPT x 1/8NPT (79470) (29714)	1	
-10	38877	ELBOW, Male, 45 deg 1/4NPT (00624)	1	
-11	C3759X4	TEE, Street, 1/4NPT x 1/4NPT x 1/4NPT (79470) (41024).....	1	
-12	116332	BUSHING, Rdcr, 3/8NPTx 1/4NPT(24617)	1	
-13	41935	ADAPTER, Straight, 1/4NPTx 3/8 tube	1	
-14	28727	FILTER SUBASSY, Trap	1	
	28726	SCREEN, Filter	1	
	28725	SCREW, Filter	1	
-15	24978	PACKING, Preformed, O-ring (77308)	1	
-16	65159	BODY, Trap	1	

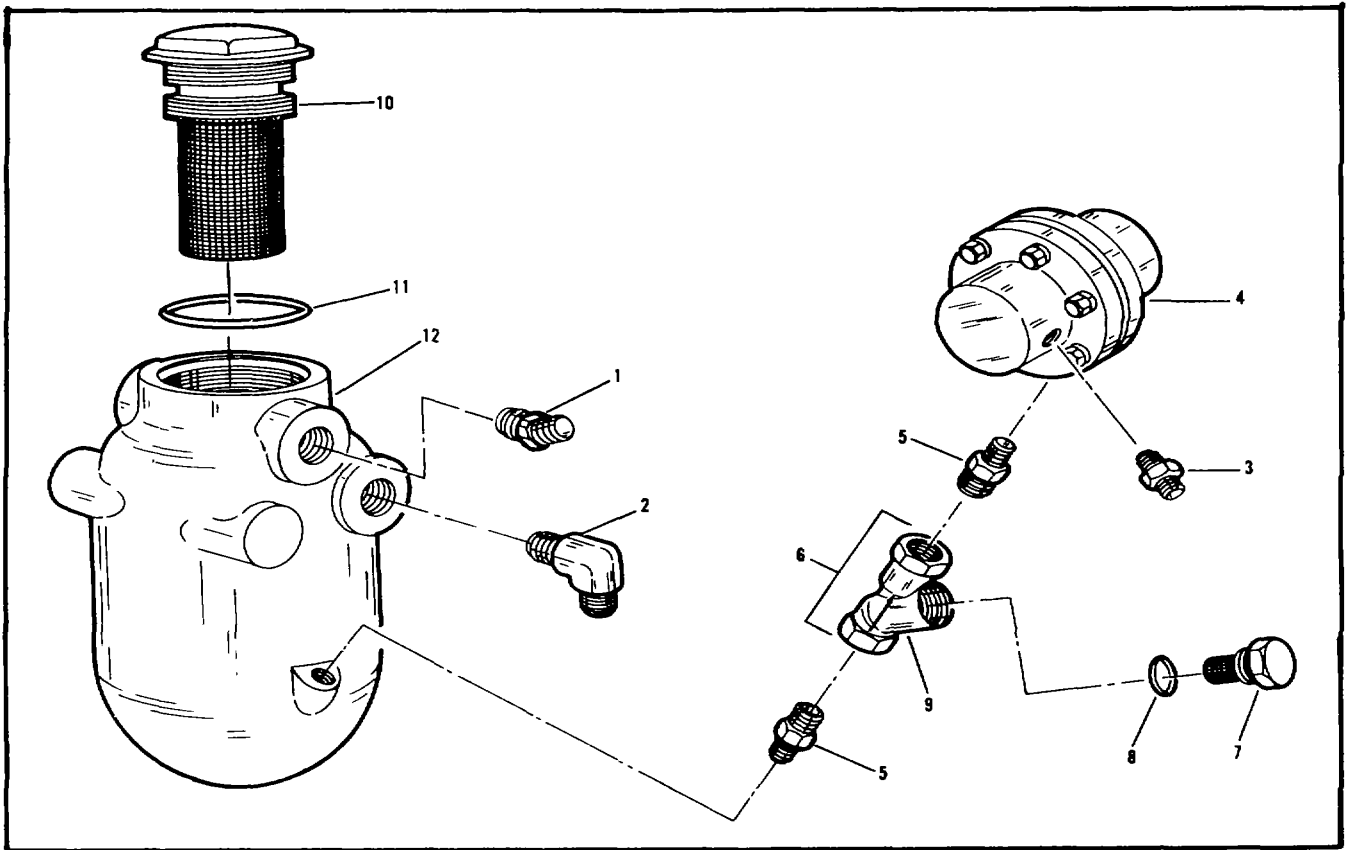

Figure 8-23. Third Stage Trap Assembly

FIGURE & INDEX NUMBER	PART NUMBER	DESCRIPTION	UNITS PER ASSY							USABLE ON CODE		
			1	2	3	4	5	6	7			
8-23	69793	TRAP ASSY, Third stage (see Figure 8-20 for NHA).....								REF		
-1	C5355X6X6	ELBOW, Male, 45 deg, 3/8NPT x 3/8 tube (79470) (69787).....									1	
-2	44294	ELBOW, Male, 90 deg, 3/8NPT x 3/8 tube.....									1	
-3	28835	ADAPTER, Straight, 1/8NPT x 1/4 tube.....									1	
-4	66449	VALVE SUBASSY, Continuous (see Figure 8-26 for detail breakdown)									1	
-5	PF10-4-2	NIPPLE, Pipe, hex, 1/4NPT x 1/8NPT (98660) (66454).....									2	
-6	66489	STRAINER SUBASSY, Line.....									1	
-7	66490	FILTER, Cap and.....									1	
-8	GVA88-2844-4	PACKING, Preformed, O-ring (084845).....									1	
-9	GVA88-284-1	BODY, Strainer.....									1	
-10	28727	FILTER SUBASSY, Trap.....									1	
	28726	SCREEN, Filter.....									1	
	28725	SCREW, Filter.....									1	
-11	24978	PACKING, Preformed, O-ring (77308).....									1	
-12	65159 B	ODY, Trap 1										

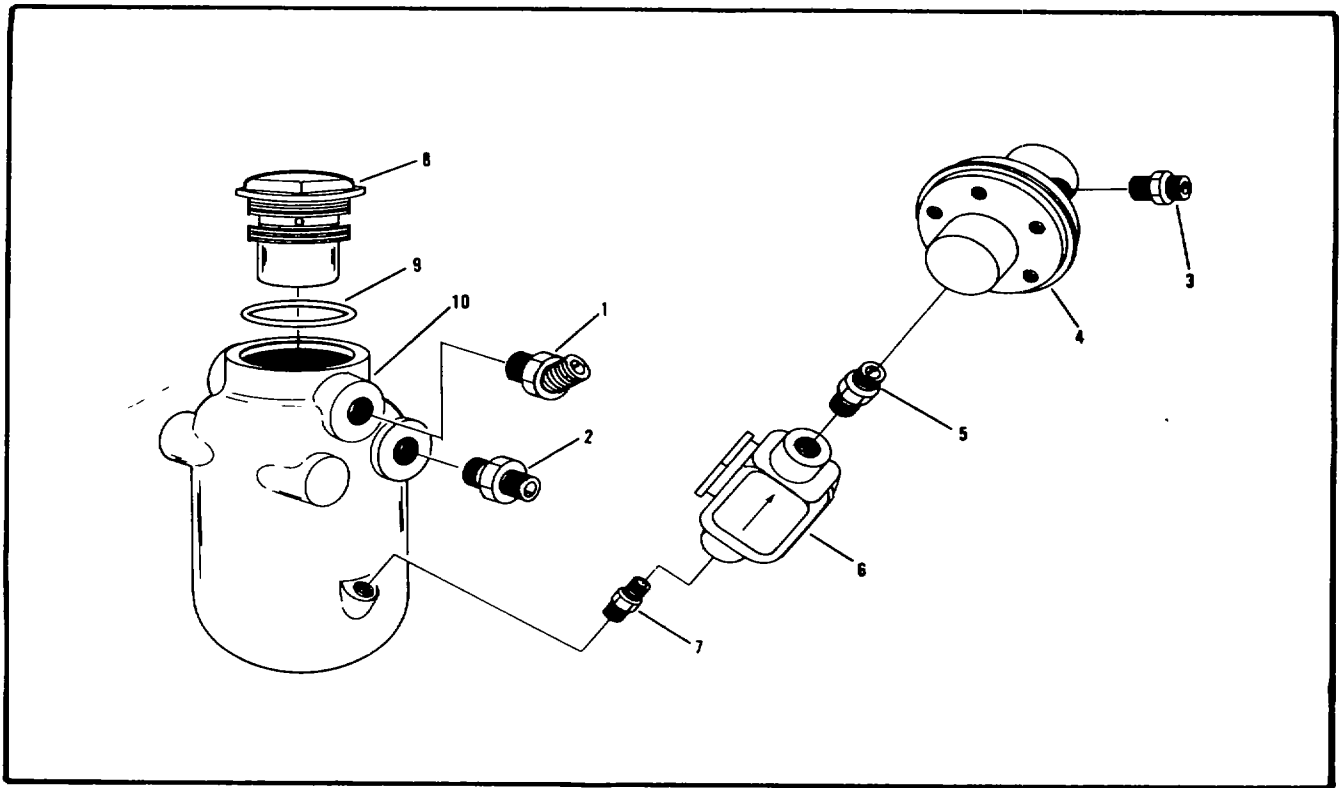

Figure 8-24. Accumulator Assembly

FIGURE & INDEX NUMBER	PART NUMBER	DESCRIPTION	UNITS	USABLE ON CODE
			PER ASSY	
		1 2 3 4 5 6 7		
8-24	84539	ACCUMULATOR ASSEMBLY (See figure 8-20 for NHA).....	REF	
1	69800	ELBOW, 450, 3/8P x 1/2 T	1	
-2	44291	CONNECTOR, 3/8 P x 1/2 T	1	
-3	49365	ADAPTOR, 1/8 x 5/16 T	1	
-4	66447	VALVE SUBASSY, Continuous Bleed (see figure 8-26 for breakdown)	1	
-5	PF10-4-2	NIPPLE, Reducer, hex 1/4NPT x 1/8NPT (48660) (66454)	1	
-6	66491	STRAINER, Line 90MC (see figure 8-25 for breakdown).....	1	
-7	41935	CONNECTOR, 1/8 P x 5/16 T	1	
-8	68626	CAP, Accumulator	1	
-9	24978	PACKING, Preformed O-ring (77308)	1	
-10	65159	BODY, Accumulator	1	

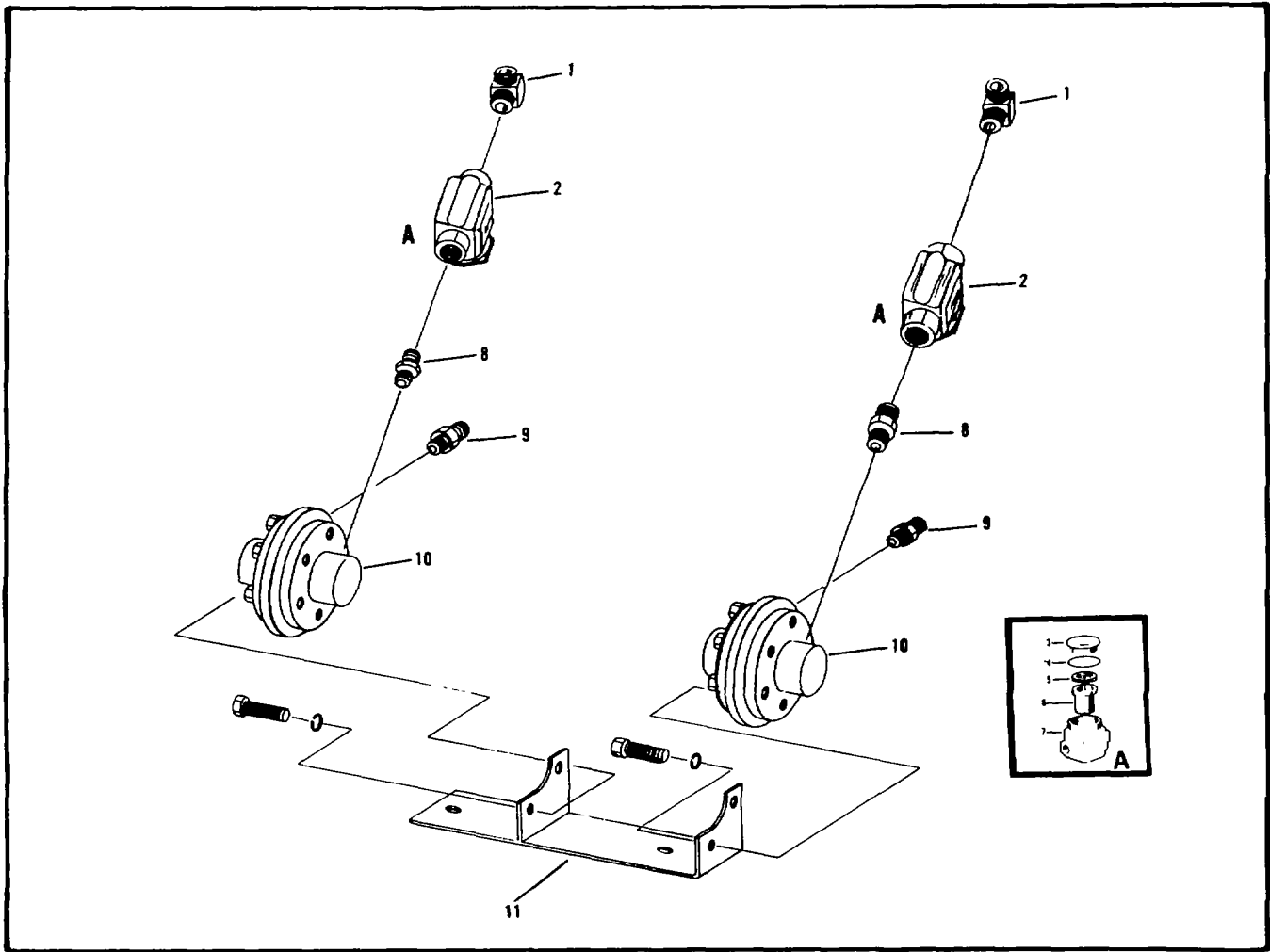

Figure 8-25. Bleed Valve Assembly

FIGURE & INDEX NUMBER	PART NUMBER	DESCRIPTION	UNITS PER ASSY							USABLE ON CODE	
			1	2	3	4	5	6	7		
8-25	84524	VALVE ASSY, Bleed (see figure 8-1 for NHA)								REF	
-1	44209	ELBOW, 1/4Px 5/16 T								2	
-2	66491	STRAINER, Line 90 MC								2	
-3	68964	PLUG, Body (NPS)								1	
-4	68967	PACKING, Preformed, O-ring								1	
-5	68963	WASHER, Seal								1	
-6	68965	ELEMENT, Strainer, 90 micron								1	
-7	68966	BODY, Strainer (NPS)								1	
-8	PF10-4-2	NIPPLE, Reducer, hex 1/4 NPT x 1/8 NPT (98660) (66454)								2	
-9	41935	CONNECTOR, Straight, 1/8 NPT x 5/16 tube								1	
-10	69883	VALVE, Bleed (see figure 8-26)								2	
-11	83982	BRACKET, Mounting								1	

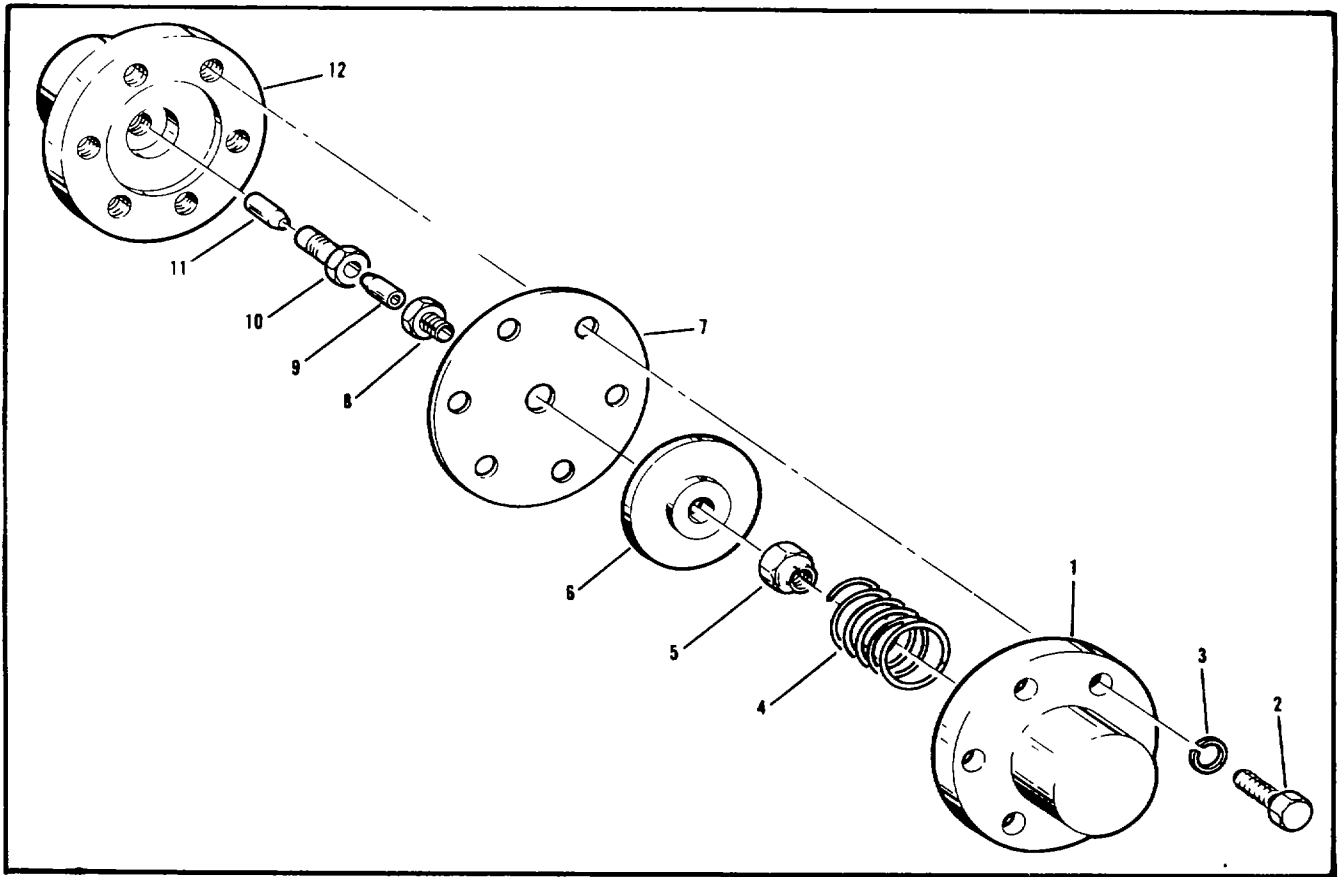

Figure 8-26. Bleed Valve Subassembly

FIGURE & INDEX NUMBER	PART NUMBER	DESCRIPTION	UNITS PER ASSY							USABLE ON CODE	
			1	2	3	4	5	6	7		
8-26	69883	VALVE SUBASSY, Cont bid, 1stg & 2stg traps.....								REF	
	66449	(see figure 8-25 for NHA) (repair kit available).....								REF	
	66447	VALVE SUBASSY, Cont bld, 3stg trap (see figure 194 for NHA)								REF	
	66447	(repair kit available)									
	66447	VALVE SUBASSY, Cont bid, accum. (see figure 8-24 for NHA) REF									
-1	65859	CAP, Valve (repair kit available).....								1	
-2	120854	SCREW, Cap, hex hd, 1/4-20NC x 5/8 n lg (AP).....								6	
-3	120380	† WASHER, Lock, split, 1/4 in (AP) (KF).....								6	
4	66452	† SPRING, Valve (used m assy no 69883 and 66447) (KF) .								1	
	66453	†† SPRING, Valve (used in assy no 66449) (KF).....								1	
-5	21NTE048	NUT, Slfkg, 1/4-28NF, thin (72962).....								1	
6	65860	††† PLATE, Diaphragm (KF).....								1	
-7	66451	††† DIAPHRAGM, Valve (KF).....								1	
-8	65861	††† SCREW, Orifice (KF).....								1	
-9	25741	††† PLUNGER, Valve (KF).....								1	
-10	66450	††† SEAT, Valve (KF).....								1	
-11	29384	VALVE, Bleed (KF).....								1	
-12	65858	BODY, Valve.....								1	
	65882	REPAIR KIT, Field, valve no 69883 & 66447.....								REF	
	65883	REPAIR KIT, Field, valve no 66449.....								REF	
		†Component of kit no 65882									
		††Component of kit no 65883									
		†††Component of kit no 65882 and 65883									

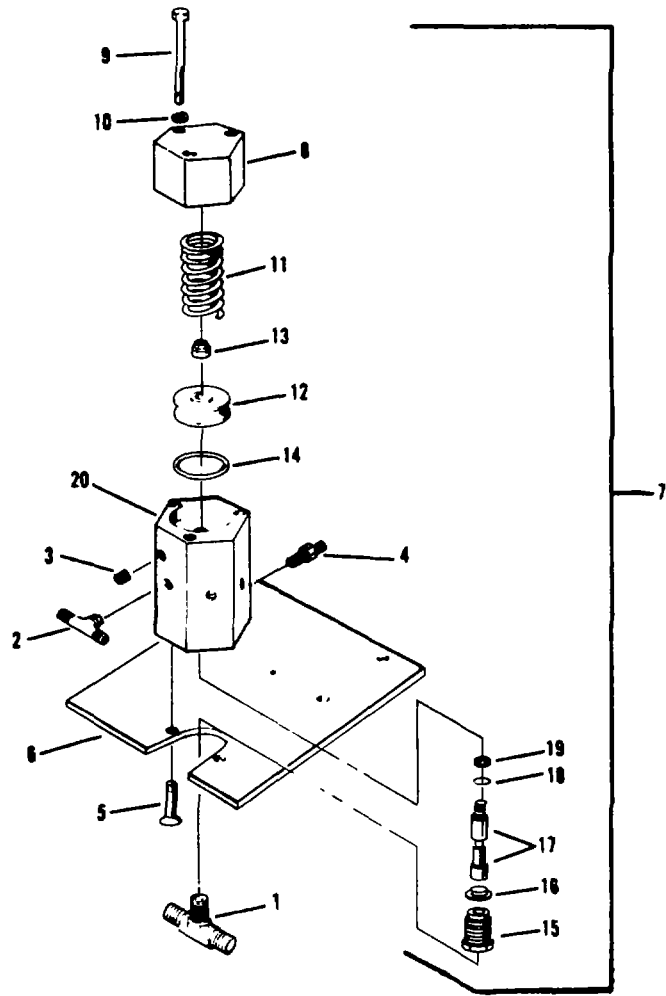

Figure. 8-27. Drain Valve Assembly

FIGURE & INDEX NUMBER	PART NUMBER	DESCRIPTION							UNITS PER ASSY	USABLE ON CODE
		1	2	3	4	5	6	7		
8-27	84525	VALVE ASSY, Drain (see figure 8-1 for NHA)							1	
-1	29397	TEE, 1/4 Tx 1/4 Tx 1/4 P							1	
-2	28845	TEE, 1/4 T x 1/4 T x 1/8 P							1	
-3	67871	PLUG, Pipe sch 1/8 NPT							1	
4	41935	CONNECTOR, 1/8 Px 5/16 T							1	
-5	65234	SCREW, Fit hd sock, 1/4 - 20 x 1							2	
-6	83983	BRACKET, Mounting							1	
	122027	SCREWS, Hex, 5/16-18 x 1-1/4 (AP)(24617)							2	
	120393	WASHER, Flat, 5/16 (AP) (24617)							2	
	443333	LOCKNUT, 5/16-18 (AP) (24617).....							2	
-7	81603	VALVE SUBASSY, Drain							1	
-8	45126	CAP, Valve 1								
-9	121966	SCREW, Cap, hex hd, 1/4 - 20NC x 2-1/2 in lg (AP) (24617)							3	
-10	120380	WASHER, Lock, split 1/4" (AP)(24617)							3	
-11	49565	†	SPRING, Valve						1	
-12	45127	PISTON, Drain valve							1	
-13	443331	NUT, Sif lk& 1/4-20NC (24617)							1	
-14	24936	†	PACKING, Preformed O-ring (77308).....						1	
-15	65175	SCREW, Valve.....							1	
-16	45128	SEAT, Valve 1								
-17	45130	STEM, Valve 1								
-18	11-008-7400-9	†	PACKING, Preformed, O-ring (81168) (45380).....							
-19	45381	†	RING, Back-up						1	
-20	45134	†	BODY, Valve						1	
	65378	REPAIR KIT, Field, drain valve							REF	
8-48										

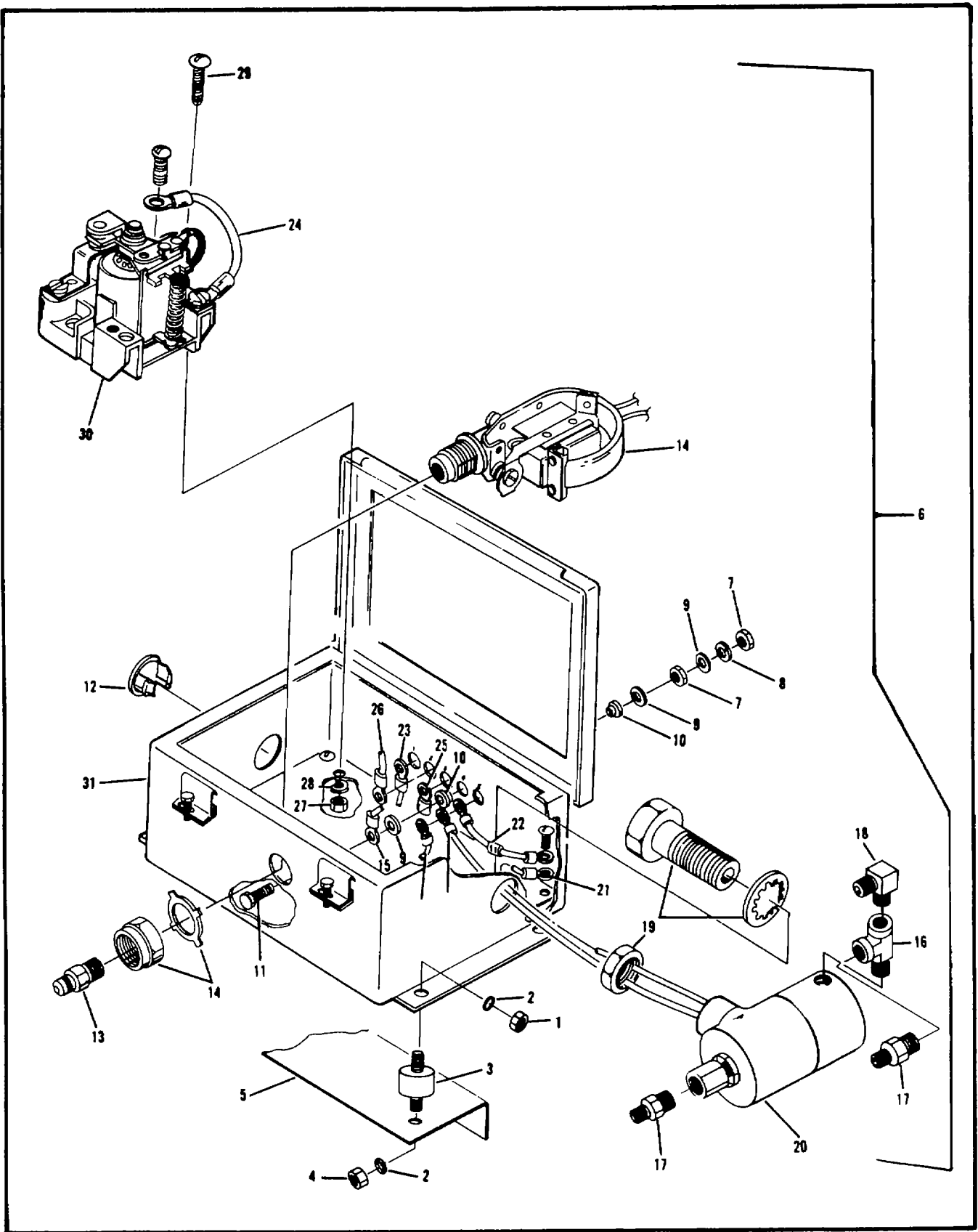

Figure 8-28. Unloader Control Box Group

FIGURE & INDEX NUMBER	PART NUMBER	DESCRIPTION							UNITS PER ASSY	USABLE ON CODE
		1	2	3	4	5	6	7		
8-28	No Number	UNLOADER CONTROL BOX GROUP (See figure 8-1 for NHA).....							REF	
-1	120376	NUT, Hex, 5/16-18 (24617)-----							6	
-2	120214	WASHER, Lock, spht 5/16" (24617).....							8	
-3	A23-041	MOUNT, Shock (81860) (80418).....							4	
4	124824	NUT, Jam,5/16-18(24617).....							2	
-5	83996	BRACKET, Mounting, unloader box.....							1	
-6	83984	CONTROL ASSY, Unloader.....							1	
-7	120361	NUT, Hex, No 10024NC (24617).....							10	
-8	120217	WASHER, Lock, spit no 10 (24617).....							5	
-9	67213	WASHER, flat, SAE no 10.....							15	
-10	65582	WASHER, Insulator.....							10	
-11	274957	SCREW, Hex hd no 10-24 x 3/4 (24617).....							5	
-12	66187	PLUG, Snap-min, 3/4" dia.....							1	
-13	69280	ADAPTOR, JIC, 450.....							1	
-14	BISC 4855	SWITCH, Pressure (89326) (65368).....							1	
-15	24855	TERMINAL, Elec. (to term no 4 and 5).....							2	
-16	41024	TEE, Straight, 1/4 NPT.....							1	
-17	43024	CONNECTOR, 1/4 x 5/16.....							2	
-18	44209	ELBOW, 900, 1/4 P x 5/16 T.....							1	
-19	84651	CONNECTOR, Union.....							1	
		WASHER, Lock, int. tooth.....							1	
		NUT, Jam.....							1	
-20	84650	VALVE, Solenoid.....							1	
-21	24855	TERMINAL, Elec. (to term no 5 and grid).....							2	
-22	66381	DIODE ASSY-.....							1	
-23	69229	WIRE ASSY (Relay to term no 1).....							1	
-24	81001-32	WIRE ASSY, Relay.....							1	
-25	69229	WIRE ASSY (Relay to term no 3).....							1	
-26	66958	WIRE ASSY (Relay to term no 2).....							1	
-27	114653	NUT, Hex, no 8-32.....							2	
-28	121841	WASHER, Lock, spit no 8.....							2	
-29	132768	SCREW, Rd hd no 8-32 x 3/4.....							2	
-30	69666	RELAY, 12 Volt.....							1	
-31	84537	BOX, Unloader, control.....							1	
8-50										

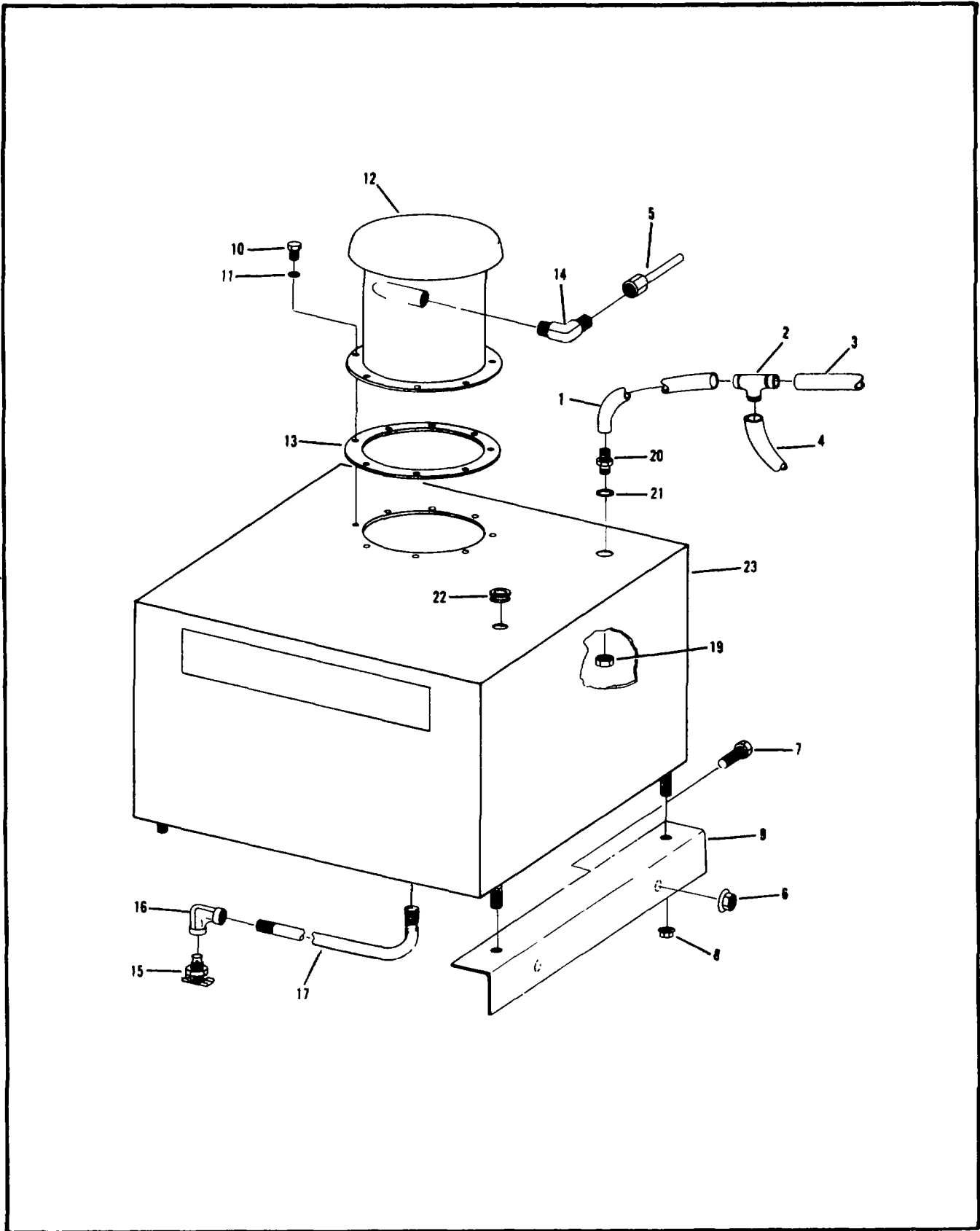

Figure 8-29. Condensate Receiver Group

FIGURE & INDEX NUMBER	PART NUMBER	DESCRIPTION							UNITS PER ASSY	USABLE ON CODE
		1	2	3	4	5	6	7		
8-29	No Number	CONDENSATE RECEIVER GROUP (See figure 8-1 for NHA) REF								
-1	50953	HOSE, Drain (tee to tank)							1	
-2	82857	TEE, Low pressure plastic 5/16 x 5/16 x 5/16.....							1	
-3	84998	HOSE ASSY, 1st stg bid valve to tee							1	
-4	84897	HOSE ASSY, Accumulator bid valve to tee							REF	
-5	84891	TUBE ASSY, Drain valve to condensate rec							1	
6	9416918	NUT, Self-locking 1/4 (24617)							4	
-7	274825	SCREW, Hex hd cap 1/4-20 x 3/4 (24617)							4	
-8	9416918	NUT, Self-locking 1/4" - 20 (24617)							4	
-9	83981	BRACKET, Mounting, right.....							1	
	83980	BRACKET, Mounting, left							1	
-10	132900	SCREW, No 10-32 x 3/8 (24617)							8	
-11	120217	WASHER, Lock no 10 (24617)							8	
-12	67077	CAP, Separator							1	
-13	67076	GASKET, Cap							1	
-14	28937	ELBOW, 1/8 P x 1/4 T							1	
-15	14026	VALVE, Drain							1	
-16	144127	ELBOW, 1/8 Standard (79420).....							1	
-17	85424	NIPPLE, 1/4 NPT, (79420)							1	
-18	Deleted									
-19	68103	NUT, Jam.....							1	
-20	68102	CONNECTOR, Hose, coupling.....							1	
-21	120394	WASHER, Flat, 3/8" (24617)							1	
-22	46355	GROMMET							1	
-23	84695	RECEIVER, Condensate.....							1	
8-52										

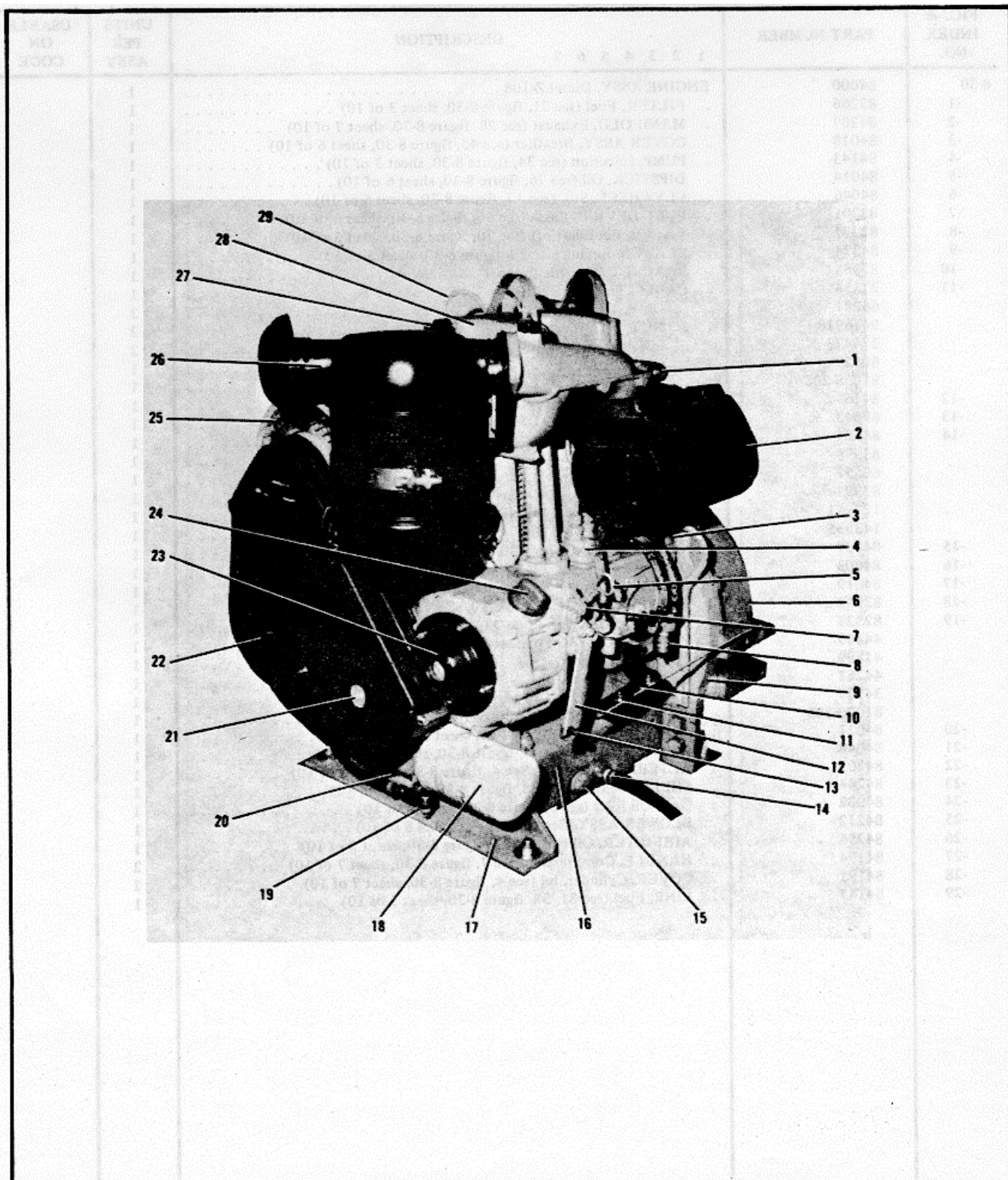

Figure 8-30. Diesel Engine Assembly (Sheet 1 of 10)

FIGURE & INDEX NUMBER	PART NUMBER	DESCRIPTION							UNITS PER ASSY	USABLE ON CODE
		1	2	3	4	5	6	7		
8-30	84000	ENGINE ASSY, Diesel Z-108.....							1	
-1	82266	FILTER, Fuel (see 21, figure 8-30, sheet 3 of 10)							1	
-2	84207	MANIFOLD, Exhaust (see 28, figure 8-30, sheet 7 of 10).....							1	
-3	84018	COVER ASSY, Breather (see 43, figure 8-30, sheet 6 of 10)							1	
4	84143	PUMP, Injection (see 34, figure 8-30, sheet 3 of 10)							1	
-5	84014	DIPSTICK, Oil (see 76, figure 8-30, sheet 6 of 10)							1	
-6	84046	FLYWHEEL, Std (see 17, figure 8-30, sheet 5 of 10)							1	
-7	82201	FUEL DEVICE, Extra (see 66, figure 8-30, sheet 6 of 10)							1	
-8	82277	VALVE, Fuel shut-off (see 70, figure 8-30, sheet 3 of 10)							1	
-9	84324	FLANGE, Engine (see 20, figure 8-30, sheet 5 of 10)							1	
-10	83985	BRACKET, Throttle support							1	
-11	27854	CABLE, Throttle							1	
	66281	CLIP, Tubing, 1/4 x 1/8.....							2	
	9416918	NUT, Serr fig, lock, 1/4-20 (24617).....							2	
	274473	SCREW, Serr fig hd, 1/4-20 (24617).....							2	
	60627	CLIP							1	
	81000-205	SCREW, Cap, M12 x 16 mm.....							1	
-12	84166	LEVER, Throttle (see 42, figure 8-30, sheet 3 of 10)							1	
-13	69643	WIRE STOP							1	
-14	84501	PLUG, Oil drain							1	
	83998	HOSE, Oil drain 17"							1	
	60597	FITTING.....							1	
	83997	BRACKET & COUPLING							1	
	127961	ELBOW, Street, 1/2 NPT							1	
	143935	PLUG, Hex, 1/2 NPT							1	
-15	84037	SIEVE (See 63, figure 8-30, sheet 6 of 10)							1	
-16	84003	CRANKCASE (See 32, figure 8-30, sheet 5 of 10)							1	
-17	84019	BRACKET, Engine mounting (see 31, figure 8-30, sheet 5 of 10)							1	
-18	82042	FILTER, Oil (see 1, figure 8-30, sheet 5 of 10)							1	
-19	82323	SWITCH, Oil pressure (see 23, figure 8-30, sheet 10 of 10)							1	
	44469	HOSE ASSY, Oil pressure							1	
	41899	ELBOW, 90							1	
	44261	TEE, Street							1	
	34937	CLIP							1	
	81000205	SCREW, Cap M12 x 16 mm.....							1	
-20	84021	PLUG, Oil (see 27, figure 8-30, sheet 5 of 10).....							1	
-21	84048	CRANKSHAFT (Sec 45, figure 8-30, sheet 4 of 10).....							1	
-22	84267	ALTERNATOR, 12V (Sec 4, figure 8-30, sheet 10 of 10)							1	
-23	84244	SHELL, Guiding (see 38, figure 8-30, sheet 2 of 10)							1	
-24	84032	CAP, Oil filler (see 5, figure 8-30, sheet 5 of 10)							1	
-25	84212	BLOWER ASSY (See figure 8-30, sheet 8 of 10)							1	
-26	84256	AIRFILTER, Oil bath (see 5, figure 8-30, sheet 2 of 10)							1	
-27	84194	HANDLE, Compression (see 7, figure 8-30, sheet 7 of 10)							2	
-28	84191	COVER, Cylinder, hd (see 4, figure 8-30, sheet 7 of 10)							2	
-29	84147	LINE, Fuel (see 31, 32, figure 8-30, sheet 3 of 10)							1	

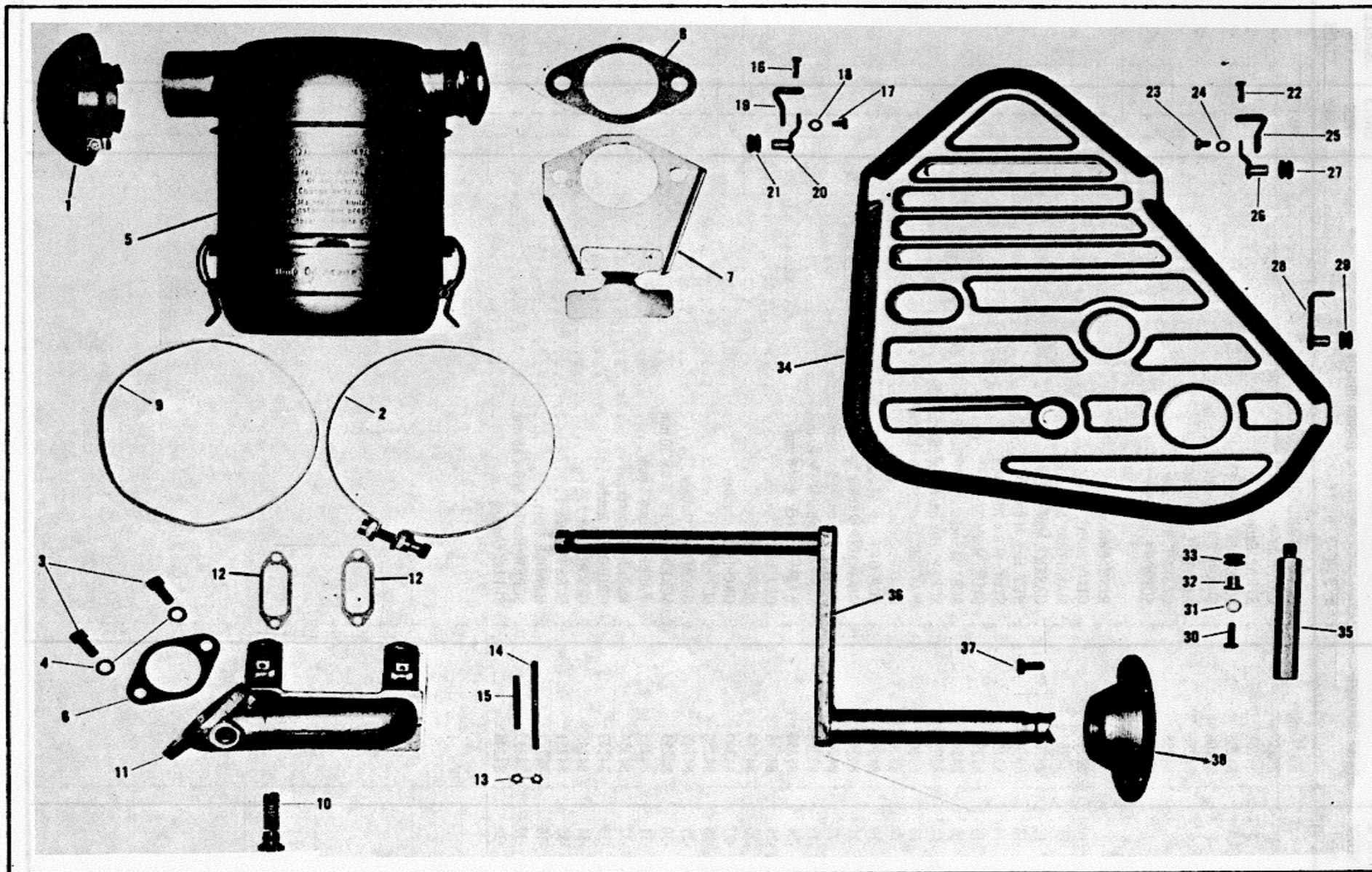

Figure 8-30. Air Intake and Guard Group (Sheet 2 of 10)

FIGURE & INDEX NUMBER	PART NUMBER	DESCRIPTION							UNITS PER ASSY	USABLE ON CODE
		1	2	3	4	5	6	7		
No Number		AIR INTAKE AND GUARD GROUP							REF	
-1	84257	CAP, Rain							1	
-2	84261	STRAP, Support.....							1	
-3	84205	SCREW, Skt hd M 12 x 25 mm.....							2	
-4	84206	WASHER, Lock, split M 12 mm							2	
-5	84256	AIR FILTER, 011 bath.....							1	
-6	84258	GASKET, Air intake.....							1	
-7	84259	SUPPORT, Breather							1	
-8	Deleted									
-9	84260	RING, Rubber							1	
-10	82325	GLOW PLUG, 183G.....							1	
-11	84202	MANIFOLD, Air intake.....							1	
-12	84204	GASKLT, Manifold							2	
-13	69348	NUT, Hex, M 8 mm							4	
-14	82159	STUD, M 8 x 70 mm.....							2	
-15	82295	STUD, M 8 x 25 mm.....							2	
-16	84248	SCREW, Socket, hd, M 5 x 20 mm							1	
-17	82058	SCREW, Hex hd, M 6 x 10 mm (AP).....							2	
-18	69353	WASHER, Lock, split 6 mm (AP)							2	
-19	84246	CLAMP.....							2	
-2f)	84247	SUPPORT.....							2	
-21	84249	GROMMET, Rubber							1	
-22	84248	SCREW, Skt hd, M 5 x 20 mm							1	
-23	82058	SCREW, Hex hd, M 6 x 10 mm.....							1	
-24	69353	WASHER, Lock, split 6 mm							1	
-25	84246	CLAMP.....							1	
-26	84247	SUPPORT.....							1	
-27	84249	GROMMET, Rubber.....							1	
-28	84250	SUPPORT.....							1	
-29	84249	GROMMET, Rubber.....							1	
-30	84253	SCREW, Hex hd M 6 x 30 mm							1	
-31	84255	WASHER, Flat 6 4 mm							1	
-32	84254	BUSHING, Spacer							1	
-33	84249	GROMMET, Rubber.....							1	
-34	84245	GUARD, Belt.....							1	
-35	84251	SCREW, Spacer							1	
-36	84243	HANDLE, Start.....							1	
-37	84233	SCREW, Hex hd, M 8 x 16 mm.....							4	
-38	84244	SHELL, Guiding							1	

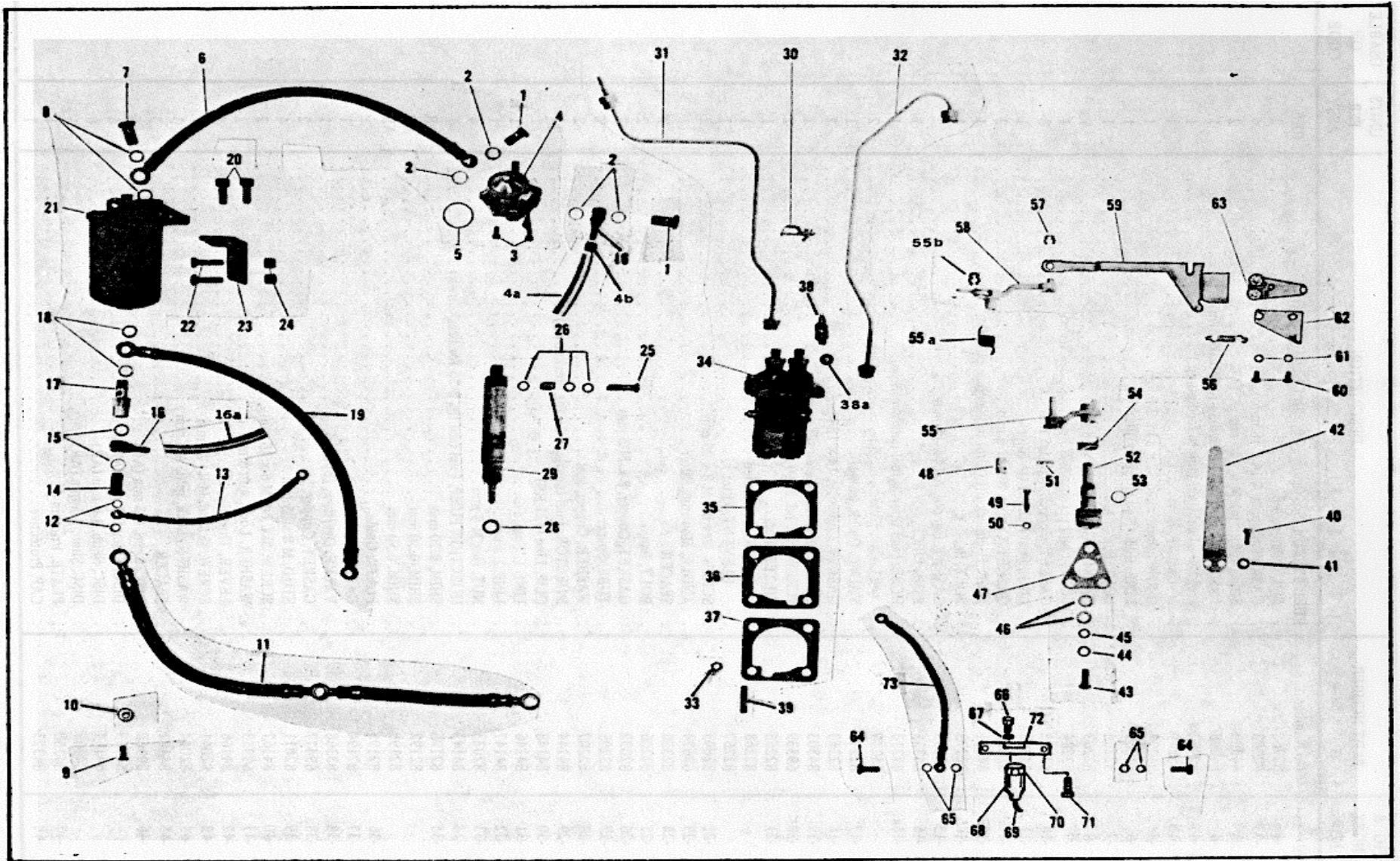

Figure 8-30. Fuel System (Sheet 3 of 10)

FIGURE & INDEX NUMBER	PART NUMBER	DESCRIPTION							UNITS PER ASSY	USABLE ON CODE
		1	2	3	4	5	6	7		
8-30	No Number	FUEL SYSTEM (See figure 8-30, sheet 1 of 10 for NHA).....							REF	
-1	82265	BOLT, Banjo, A 8							2	
-2	82263	GASKET, Copper A 14 x 18 mm							4	
-3	84302	SCREW, Skt hd M 6 x 16 mm							2	
-4	84298	PUMP, Fuel feed (see figure 8-34 for breakdown).....							1	
-4A	85452	LINE, Fuel (fuel tank to feed pump).....							1	
4b	65249	CLAMP, Hose							1	
-5	84299	O-RING, Preformed 32 x 33 x 2.5 mm							1	
-6	82269	LINE, Fuel (feed pump to filter)							1	
-7	82265	BOLT, Banjo, A8							1	
-8	82263	GASKET, Copper A 14 x 18 mm							2	
-9	82284	BOLT, Fluid passage A 2/3							1	
-10	82032	GASKET, Copper, 8 x 11.5 mm							2	
-11	84304	LINE, Fuel leak-off (to filter)							1	
-12	82032	GASKET, Copper, 8 x 11.5 mm							2	
-13	84331	LINE, Fuel, leak-off (filter to injection pump).....							1	
-14	82273	BOLT, Banjo							1	
-15	82263	GASKET, Copper, A 14 x 18 mm							2	
-16	84332	RING PIECE, NW 8							1	
-16a	47213	HOSE, Fuel filter to fuel tank overflow							1	
	65249	CLAMP, Hose							2	
-17	82271	VALVE, Check, leak-off							1	
-18	82263	GASKET, Copper, A 14 x 18 mm							2	
-19	84303	LINE, Fuel (filter to shut-off valve)							1	
-20	69339	SCREW, Hex hd, M 10 x 15 mm							2	
-21	82266	FILTER, Fuel.....							1	
	82268	O-RING, Preformed							1	
	82267	ELEMENT, Filter							1	
-22	82045	SCREW, Hex hd, M 8 x 25 mm							2	
-23	69674	ANGLE, Mounting, Filter							1	
-24	82326	SPACER							2	
-25	82206	BOLT, Banjo							2	
-26	82032	GASKET, Copper, 8 x 11.5 mm							3	
-27	82205	TUBE, Spacer							2	
-28	82207	WASHER, Copper, seal							2	
-29	84144	INJECTOR, Fuel (see fig 8-36 for breakdown)-							2	
-30	84148	CLIP, Line (421-RS).....							1	
-31	84146	LINE 1, Fuel							1	
-32	84147	LINE 2, Fuel							1	
-33	82033	NUT, Hex M 8 mm							4	
-34	84143	INJECTION PUMP, Fuel (see fig 8-35 for breakdown)							1	
-35	82196	SHIM, 0.20 mm							AR	
	82197	SHIM, 0.30 mm							AR	
	82198	SHIM, 0.50 mm							AR	
-36	82195	PLATE, Guide							1	
-37	82194	GASKET							1	
-38	83368	VALVE, Overflow, (bypass)							1	
-38a	69477	GASKET, Copper.....							2	
-39	82011	STUD, M 8 x 25 mm.....							4	
-40	84167	SCREW, Skt hd M 6 x 16 mm							2	
-41	69353	WASHER, Lock, split 6 mm							2	
-42	84166	LEVER, Throttle							1	
-43	82041	SCREW, Skt hd M 8 - 20mm							1	
-44	82044	WASHER, Lock, split, A 8 mm							3	
-45	84181	SPACER							3	
-46	84162	DISC, Shim, 0.3 mm (AR)							6	
	84163	DISC, Shim, 0.5 mm (AR)							6	
	84164	DISC, Shim, 1.0 mm (AR)							6	
	84165	DISC, Shim, 1.5 mm (AR)							6	
-47	8416cJ	PLATE Friction							1	
-48	84323	CAP, Protective.....							1	

FIGURE & INDEX NUMBER	PART NUMBER	DESCRIPTION							UNITS PER ASSY	USABLE ON CODE
		1	2	3	4	5	6	7		
49	84159	SCREW, Set, M 6 x 25 mm.....							2	
-50	69372	NUT, Jam M 6 mm.....							2	
-51	82112	PIN, 4 x 18mm							1	
-52	84149	SHAFT, Throttle assy.....							1	
-53	82102	O-RING, Preformed 12 x 16 x 2 mm							1	
-54	84150	SPRING							1	
-55	84151	LEVER, Connecting							1	
-55a	84335	SPRING, Lever-.....							1	
-55b	84370	CLIP, Retainer, 8 x 0 8 mm.....							1	
-56	84152	SPRING							1	
-57	84155	CLIP, Retainer							1	
-58	84153	LEVER, Governor							1	
-59	84154	CONTROL ROD.....							1	
40	84158	SCREW, Hex hd M 6 x 20 mm.....							2	
-61	69353	WASHER, Lock, 6 mm.....							2	
-62	84157	SUPPORT.....							1	
43	84156	GUIDE, Support.....							1	
-64	82280	BOLT, Banjo							2	
-65	82005	GASKET, Copper --							4	
-66	69401	SCREWS, Hex hd M 6 x 12							2	
-67	82261	WASHERS, Lock, spit 6 mm							2	
68	84377	CAP, Protective.....							1	
-69	84378	WIRE ASSY, Solenoid							1	
-70	82277	SOLENOID VALVE, Fuel shut-off							1	
-71	84036	SCREWS, Allen hd, M 8 V 25							2	
-72	84379	BRACKET, Mounting							1	
-73	84380	FUEL LINE, Shut-off valve to injection pump							1	
8-59										

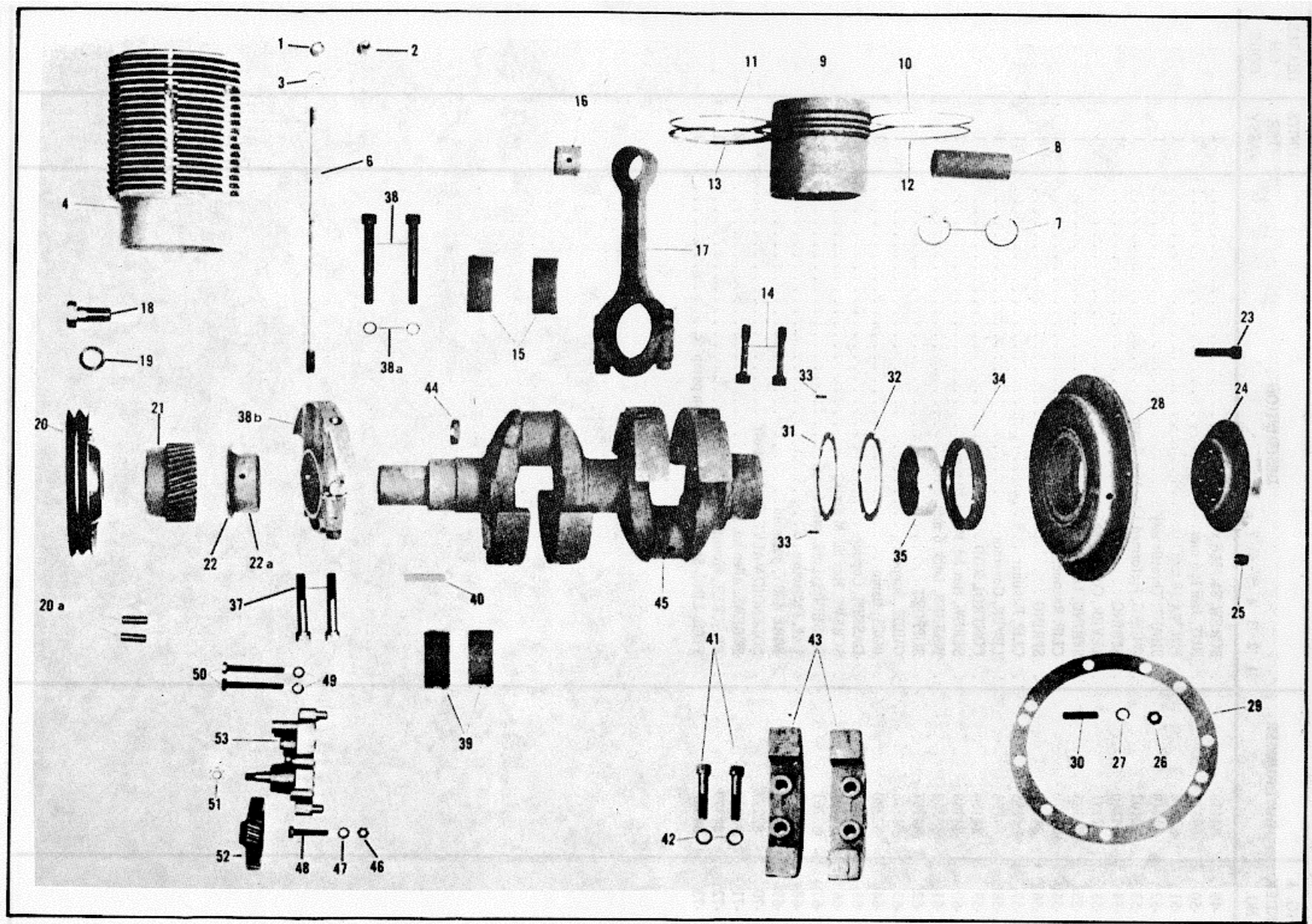

Figure 8-30. Piston, Cylinder and Crank Group (Sheet 4 of 10)

FIGURE & INDEX NUMBER	PART NUMBER	DESCRIPTION 1 2 3 4 5 6 7	UNITS PER ASSY	USABLE ON CODE
8-30	No Number	PISTON, CYLINDER AND CRANK GROUP	REF	
-1	84113	NUT, Collar	6	
-2	84114	NUT, Collar for strap	4	
-3	84112	DISC (Washer).....	10	
-4	84108	CYLINDER		2
	84109	CYLINDER, + 1.0 mm OVS	AR	
-5	Deleted			
-6	84111	STUD, Cylinder	10	
-7	84092	CLIP, Retainer	4	
-8	84091	PIN, Piston		2
-9	84090	PISTON	2	
-10	84096	WEDGE TYPE RING (Groove I)	2	
	84097	WEDGE TYPE RING, 1.0 +mm (Groove I)	AR	
-11	84098	COMPRESSION RING, (Groove I).....	2	
	84099	COMPRESSION RING, 1.0 + mm OVS (Groove II)	AR	
-12	84100	STEPPED SCRAPER RING, (Groove III)	2	
	84101	STEPPED SCRAPER RING, 1.0 + mm OVS (Groove III)	AR	
-13	84102	OIL CONT RING, Narrow faced, (Groove IV).....	2	
	84103	OIL CONT RING, Narrow faced, 1 + 0 mm OVS (Groove IV).....	AR	
-14	84105	SCREW, Connecting rod 12 mm.....	4	
-15	84106	BEARING, Rod (large end) 2	2	
	84107	BEARING, Rod, 0 5 mm UNS (large end)	AR	
-16	84104	BEARING, Rod (small end).....	2	
-17	84333	ROD, Connecting	2	
-18	84083	SCREW, Hex hd (pulley).....	1	
-19	84084	WASHER, Lock, split 20 mm	1	
-20	84082	SHEAVE -	1	
-20a	84085	PIN, Spiral, 10 x 30 mm	2	
-21	84059	GEAR WHEEL, Camshaft 15	1	
-22	84077	RING, Buffer	1	
-22a	84076	BEARING, Main	1	
-23	84063	SCREW, Skt hd, 6 BK M 12 x 40 mm	8	
-24	84060	HUB, Flywheel	1	
-25	84062	BUSHING	1	
-26	82082	NUT, Hex, M 10 mm	9	
-27	69338	WASHER, Lock, split, 10 mm	9	
-28	84064	FLANGE, Bearing	1	
-29	84081	GASKET, Flange	1	
-30	82013	STUD, M 10 x 20 mm.....	9	
-31	84080	SHIM, Flywheel end.....	AR	
-32	84079	RING, Buffer, flywheel end.....	1	
-33	84075	PIN, 4.5 x 1 4 mm	2	
-34	84078	SEAL, Oil, 90 x 110 x 15 mm	1	
-35	84074	BEARING, Main, flywheel end.....	1	
-36	Deleted			
-37	84055	SCREW, Skt hd M 12 x 70 mm (AP)	2	
-38	84057	SCREW, Skt hd M 12 x 95 mm	2	
-38a	84058	USIT-RING (Lock), 12 7 x 18 x 1 5 mm.....	2	
-38b	84054	SUPPORT, Bearing	1	
-39	84056	BEARING, Crankshaft.....	1	
-40	84053	KEY, Shaft A 10 x 8 x 50 mm	1	
-41	84051	SCREW, Skt hd M 12 x 15 x 55 mm	8	
-42	84052	WASHER, Lock, split, 12 mm	8	
-43	84049	COUNTERWEIGHT	4	
	84094	PISTON RING KIT	1	
	84096	WEDGE TYPE RING (Groove I)	1	
	84098	COMPRESSION RING (Groove II).....	1	
	84100	STEPPED SCRAPER RING (Groove III)	1	
	84112	OIL CONT. RING (Groove IV)	1	
	84095	PISTON RING KIT, 1 0 + mm OVS	1	
84097	WEDGE TYPE RING, 1	00 + mm OVS (Groove I)	1	

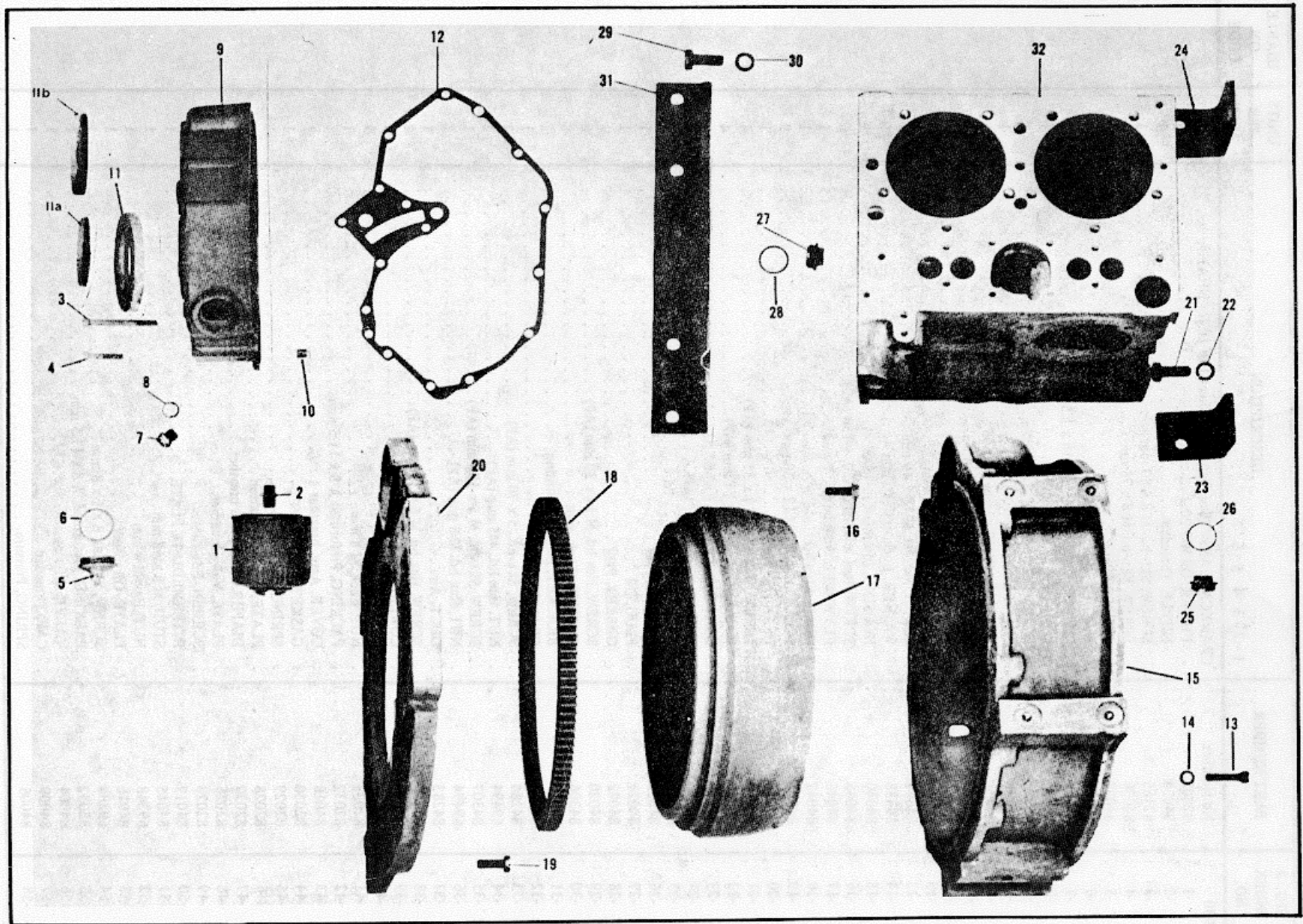

Figure 8-30. Crankcase Assembly (Sheet 5 of 10)

FIGURE & INDEX NUMBER	PART NUMBER	DESCRIPTION							UNITS PER ASSY	USABLE ON CODE
		1	2	3	4	5	6	7		
8-30	No Number	CRANKCASE ASSY (See figure 8-30, sheet 1 of 10 for NHA)							1	
-1	82042	FILTER, Oil W 9 20							1	
-2	84034	NIPPLE, Threaded							1	
-3	82185	SCREW, Skt hd M 8 x 80 mm							1	
4	84036	SCREW, Skt hd M 8 x 75 mm							13	
-5	84032	CAP, Oil filler -							1	
-6	84033	WASHER, 36 x 44 x 4 mm							1	
-7	84031	PLUG, Governor housing M 16 x 1.5 mm							1	
-8	84030	O-RING, A 16 x 22 mm							1	
-9	84027	HOUSING, Governor							1	
-10	84028	PIN, 11 x 12 mm							1	
-11	84371	BALL BEARING, Grooved 1605							1	
-IIa	84029	OIL SEAL, 70 x 85 x 8/9 mm							1	
-IIb	84372	OIL SEAL, 82 x 100 x 13 mm							1	
-12	84035	GASKET, Governor housing							1	
-13	84041	SCREW, Skt hd M 10 x 40 mm							11	
-14	-14	69338 WASHER, Lock, split 10 mm							11	
-15	84040	HOUSING, Intermediate (SAE 4)							1	
-16	84045	SCREW, Hex hd M 12x 30, 4-130 (AP)							6	
-17	84046	FLYWHEEL, Standard							1	
-18	-18	84047 GEAR, Flywheel							1	
-19	84325	SCREW, Hex hd M 12 x 30 mm							9	
-20	84324	FLANGE, Engine							1	
-21	84328	SCREW, Hex hd M 14 x 35 mm (AP)							4	
-22	84306	WASHER, Lock, split 14 mm (AP)							4	
-23	84327	ENGINE BRACKET, Right							1	
-24	84326	ENGINE BRACKET, Left							1	
-25	84501	PLUG, Oil drain							1	
-26	84022	GASKET, Plug							1	
-27	84021	PLUG, Oil 1							1	
-28	84022	GASKET, Plug							1	
-29	84020	SCREW, Hex hd, M 14 x 30 mm (AP)							8	
-30	84306	WASHER, Lock, split							8	
-31	84019	BRACKET, Engine mounting							1	
-32	84003	CRANKCASE							1	
-33	84284	SCREW, Skt hd, 5 x 70 mm (AP)							2	
-34	69494	NUT, Hex hd, M5 mm (AP)							2	
-35	84307	SCREW, Skt hd M 5 x 100 mm (AP)							1	
-36	69494	NUT, Hex hd M 5 mm (AP)							1	
-37	84283	DUCT, Air - 1							1	
-38	82058	SCREW, Hex hd M 6 x 10 mm (AP)							2	
-39	84281	COWLING, Cylinder							1	
-40	84282	DUCT, Air							1	
41	82033	NUT, Lock, M 8 mm							1	
-42	82032	PACKING, Preformed A 8 x 11 5 mm							1	
-43	84018	COVER, Assy, breather							1	
44	82030	GASKET, Breather							1	
-45	82029	SPRING, Breather							1	
-46	82028	PLATE, Stroke limitation							1	
47	82027	DIAPHRAGM, Valve breather							1	
-48	82026	PLATE, Valve breather							1	
-49	82023	SCREEN, Filter							1	
-50	84017	INTERMEDIATE PLATE							1	
-51	84015	STUD, M 8 x 65 mm							1	
-52	69348	NUT, Hex M 8 mm							1	
-53	84016	PLATE, Oil splash							1	
-54	69384	SCREW, Skt hd, 8 x 1 x 8 mm							1	
-55	82032	PACKING, Preformed, A 8 x 115 mm							1	
-56	84004	VALVE 1							1	
-57	84009	CAP, Threaded							1	
-58	84006	SPIRING, Pressure							1	

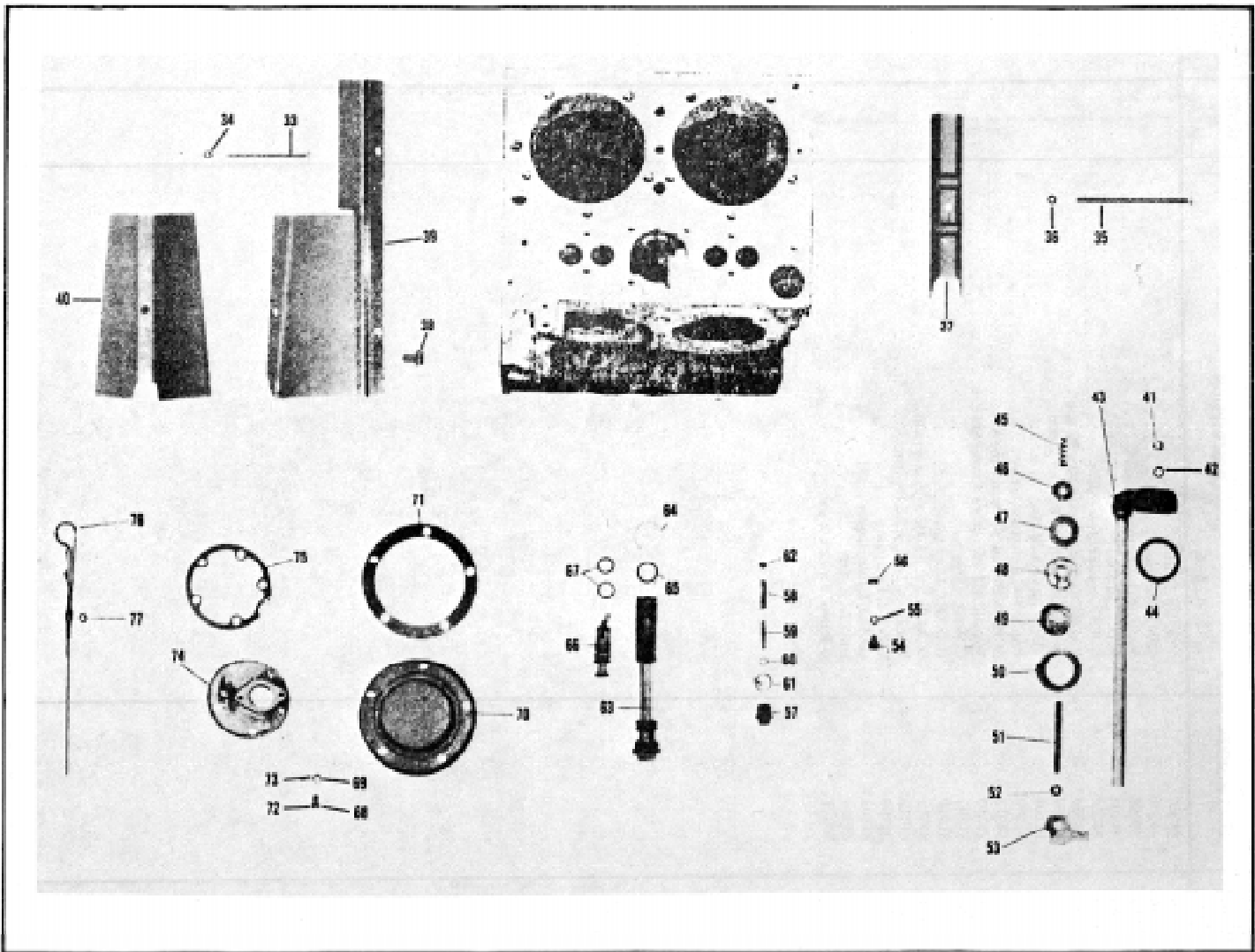

Figure 8-30. Crankcase Assembly (Sheet 6 of 10)
8-65

FIGURE & INDEX NUMBER	PART NUMBER	DESCRIPTION							QTY PER ASSY	USABLE ON CODE
		1	2	3	4	5	6	7		
59	84007	.PIN, 5 x 32 mm							1	
-60	84330	.DISC, 6 4 mm							AR	
-61	84008	.PACKING, Performed							1	
-62	84005	.BALL, 10 mm III							1	
-63	84037	.SUCTION NIPPLE W/ Steve							1	
-64	84039	.PACKING, Performed A 30 x 36 mm.....							1	
465	84038	.WASHER, Suction 20 x 26 x 3 mm							1	
-66	82201	.FUEL DEVICE, Extra							1	
4-67	82200	.PACKING, Performed, o-ring							2	
-68	84013	.SCREW, Skt hd M 8 x 16 mm (AP)							15	
-69	84012	.WASHER, Lock, split 8 4 mm (AP)							15	
-70	84001	.COVER, Large							3	
-71	84010	.GASKET, Large cover							3	
-72	84013	.SCREW, Skt hd M8 x 16 mm (AP)							5	
-73	84012	.WASHER, Lock, split, 8 4 mm (AP)							5	
-74	84300	.COVER, Fuel pump.....							1	
-75	84301	.GASKET, Pump cover.....							1	
-76	84014	.DIPSTICK, Oil O							1	
-77	82021	.O-RING, 8 x 12 x 2 mm.....							1	
8-66										

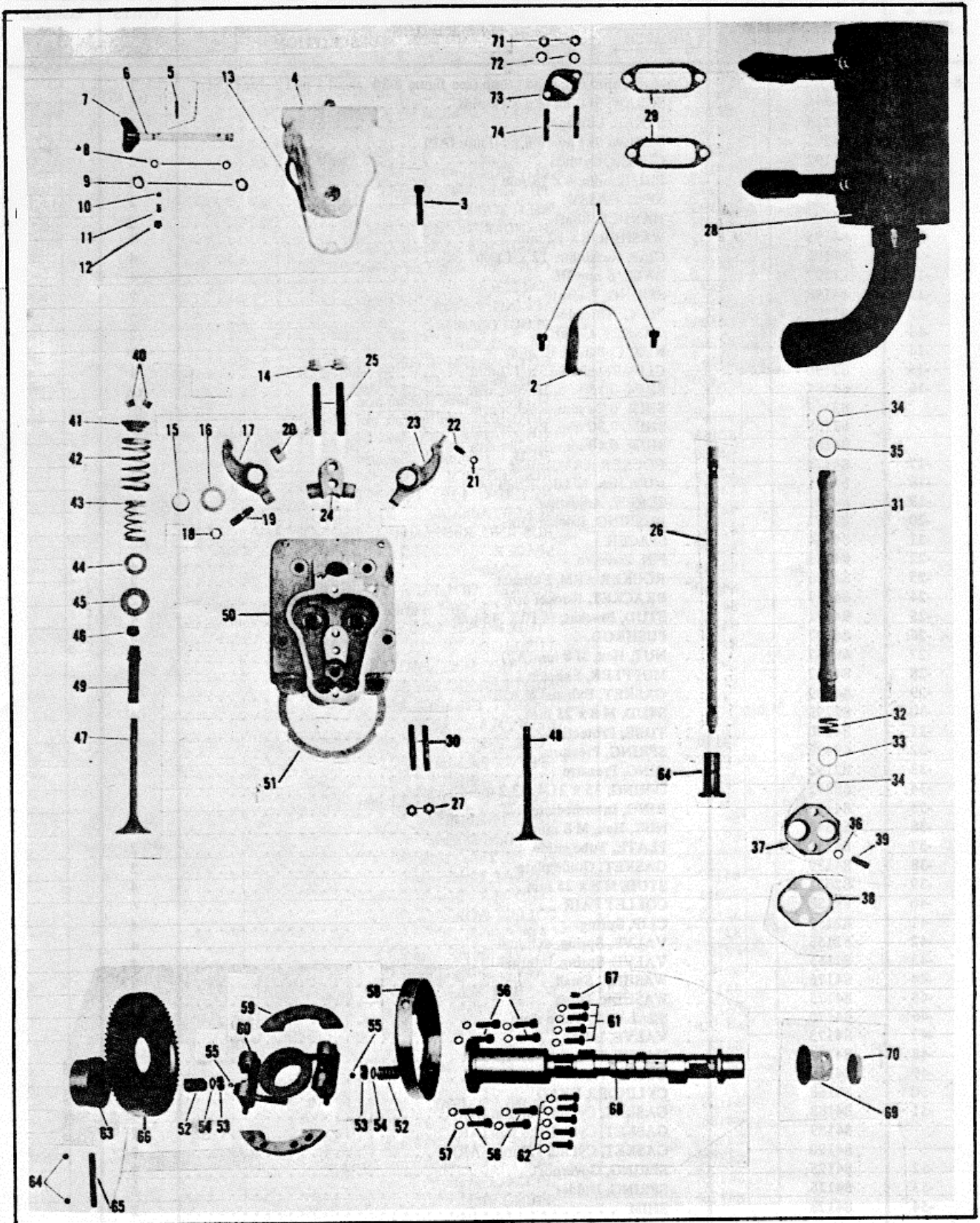

Figure 8-30. Cam, Pushrod and Head Group (Sheet 7 of 10)
8-67

FIGURE & INDEX NUMBER	PART NUMBER	DESCRIPTION							QTY PER ASSY	USABLE ON CODE
		1	2	3	4	5	6	7		
8-30	No Number	CAM, Pushrod and head group (see figure 8-30 sheet 1 of 10 for NHA)							1	
-1	82246	SCREW, Skt hd, M 8 x 12 mm							4	
-2	84115	STRAP, Lifting.....							2	
-3	84201	SCREW, Skt hd, M 8 x 50 mm (AP)							4	
-4	84192	COVER, Cyl hd s.....							2	
-5	82112	PIN ,Handle, 4 x 18 lmm							2	
-6	84193	SHAFTASSY							2	
-7	84194	HANDLE, Shaft							2	
-8	84195	WASHER, 8 x 12 mm							4	
-9	84196	CLIP, Retaining 12x 1 mm.....							4	
-10	84197	BALL, 6 mmll.....							4	
-11	84198	SPRING, Pressure							2	
-12	84199	PLUG, Threaded ----							2	
-13	84200	GASKET, Cover							2	
-14	84187	NUT,Collar,M 10 mm.....							4	
-15	82170	CLIP,Retainer, 19 x 1 2 mm							4	
-16	84185	SHIM, 0.15 m, Rocker arm							AR	
	82167	SHIM, 0 20 mm, Rocker arm							AR	
	82168	SHIM, 0.30 mm, Rocker arm							AR	
	84186	SHIM, 0.40 mm, Rocker arm							AR	
-17	84179	ROCKERARM, Intake							2	
-18	84182	NUT, Hex, MIO 10 x 1 mm(AP)							4	
-19	84181	SCREW, Adjusting								
-20	82162	BUSHING, Rocker arm							4	
-21	84184	SPACER							AR	
-22	84183	PIN, Pressure							2	
-23	84180	ROCKER ARM, Exhaust							2	
-24	84177	BRACKET, Rocker arm							2	
-25	84171	STUD, Bracket, M IOx 45 mm							4	
26	84137	PUSHROD							4	
-27	69537	NUT, Hex, M 8 mm(AP).....							4	
-28	84207	MUFFLER, Exhaust.....							1	
-29	84209	GASKET, Exhaust & Air							4	
-30	82295	STUD, M 8 x 25 mm.....							4	
-31	84140	TUBE, Protection							4	
-32	69498	SPRING, Pressure							4	
-33	82192	RING, Pressure							8	
-34	69342	O-RING, 15 x 21.4 x 3 2 mm							8	
-35	84141	RING, Intermediate							4	
-36	69348	NUT, Hex, M 8 mm.....							4	
-37	84138	PLATE, Tube guide							2	
-38	84139	GASKET, Guide plate							2	
-39	82011	STUD, M 8 x 25 mm.....							4	
40	82158	COLLET PAIR							4	
-41	82157	CLIP, Spring.....							4	
-42	82156	VALVE, Spring, external.....							4	
-43	82155	VALVE, Spring, internal.....							4	
-44	84176	WASHER, Small							4	
-45	84175	WASHER, Large							4	
-46	84170	SEAL CAP, Valve stem							4	
47	84173	VALVE, Inlet.....							2	
48	84174	VALVE ,Exhaust.....							2.	
-49	84169	GUIDE, Valve.....							4	
-50	84168	CYLINDER HEAD.....							2	
-51	84188	GASKET, Cyl hd, 0.6 mm (AR)							2	
	84189	GASKET, Cyl hd, 0 8 mm (AR)							2	
	84190	GASKET, Cyl hd, 1 0 mm (AR)							2	
-52	84125	SPRING, Governor.....							2	
-53	84126	SPRING, Holder.....							2	
-54	84128	SHIM							2	
8-68										

FIGURE & INDEX NUMBER	PART NUMBER	DESCRIPTION 1 2 3 4 5 6 7	QTY PER ASSY	USABLE ON CODE
-55	84117	. BALL 2		
-56	84131	. SCREWS, 8 mm	8	
-57	84129	. WASHERS, Lock, spit, 8 mm	8	
-58	84127	. SPRING, Support	1	
-59	84130	. BRACKETS.....	2	
-60	84123	. WEIGHTS	2	
61	84116	. SCREW	9	
-62	84134	. WASHER, Lock.....	9	
-63	84136	. SLEEVE, Hand-start	1	
-64	84118	. BALL	2	
-65	84119	. PIN, Sleeve.....	1	
-66	84120	. GEAR WHEEL	1	
-67	84121	. PIN	1	
-68	84122	. CAMSHAFT	2	
69	84124	. BEARING, Camshaft, rear		
-70	84135	. END COVER.....	1	
-71	69348	. NUT, Hex, M 8 mm	2	
-72	82044	. WASHER, Lock, spit 8 mm	2	
-73	84388	. STRAP, Hold down	2	
-74	84172	. STUDS, M 8 x 50 mm	2	
8-69				

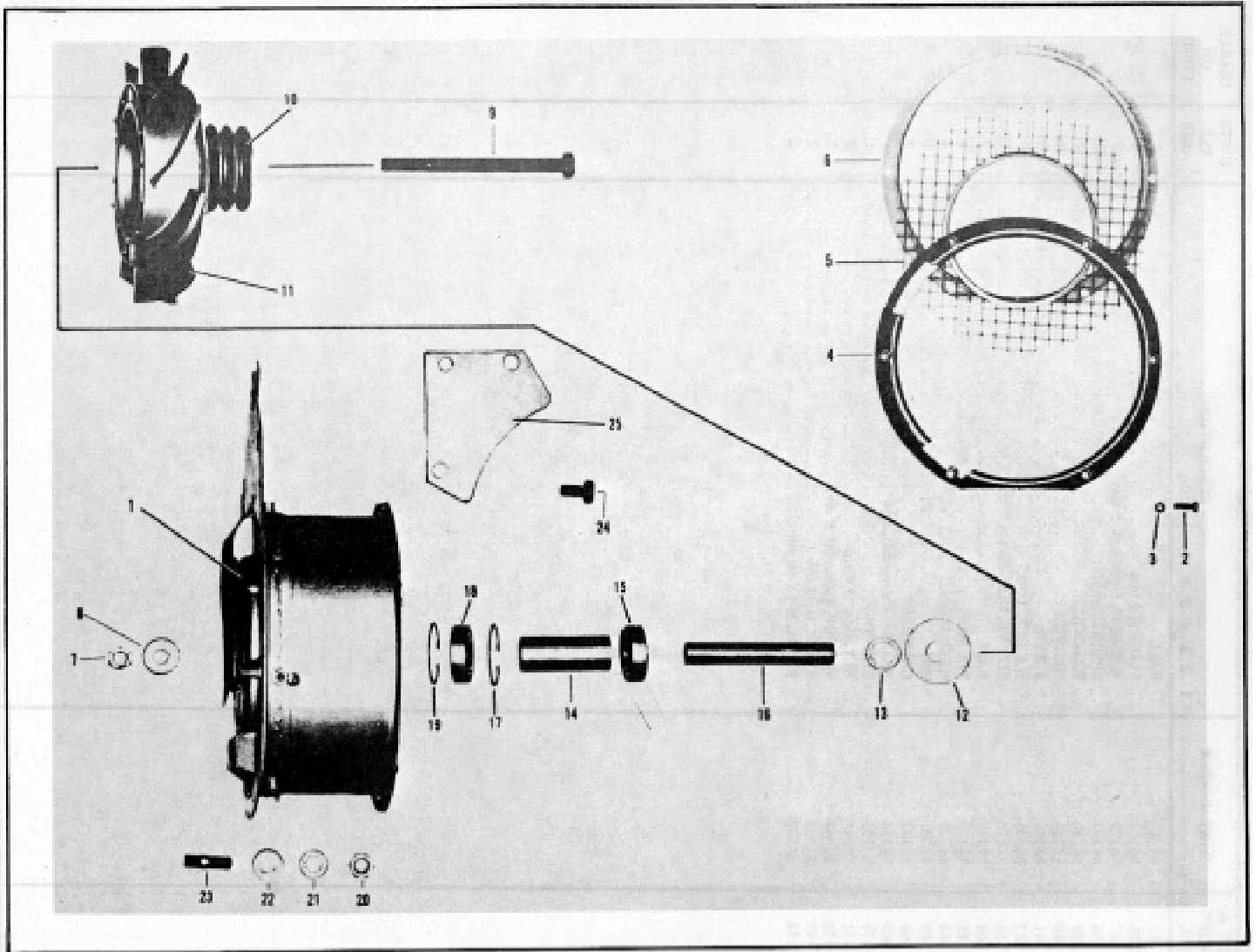

Figure 8-30. Blower Group (Sheet 8 of 10)

FIGURE & INDEX NUMBER	PART NUMBER	DESCRIPTION	QTY PER ASSY	USABLE ON CODE
8-30	No Number	. BLOWER GROUP (See figure 8-30, sheet 1 of 10 for NHA ... REF		
-1	84212	. BLOWER ASSEMBLY	1	
-2	84227	. SCREW, Skt hd M 5 x 16 mm (AP)	6	
-3	69494	. NUT, Hex, M 5 mm (AP).....	6	
-4	84226	. RING, Outer	1	
-5	84224	. SCREEN, Protection	1	
-6	84225	. RING, Inner	1	
-7	84223	. NUT, Hex, M 12 x 1 5 mm	1	
-8	84221	. WASHER	1	
-9	84222	. SCREW, Hex hd M 12 x 1 5 x 15 mm.....	1	
-10	84218	. PULLY, V-Belt	1	
-11	84213	. WHELL, Running (fan	1	
-12	84220	. WASHER	1	
-13	84219	. WASHER	1	
-14	84215	. BUSHING.....	1	
-15	84216	. BALL BEARING, Grooved 6204	2	
-16	84214	. SHAFT, Blower.....	1	
-17	84217	. CLIP, Retainer 47 x 1 5 mm	2	
-18	Deleted.			
-19	Deleted			
-20	69523	. NUT, Hex, M 12 mm.....	2	
-21	84237	. WASHER, Flat 13 mm	2	
-22	84236	. TUBE, Spacer	2	
-23	69525	. STUD, M 12 x 25 mm.....	2	
-24	84235	. SCREW, Hex hd cap M 10 x 20 mm	3	
-25	84234	. PLATE, Support	1	
-26	84233	. SCREW, Hex hd cap M 8 x 16 mm (AP)	5	
-27	82024	. WASHER, Flat, 8 4 mm (AP)	5	
-28	84228	. DUCTING, Blower.....	1	
-29	84232	. SCREW, Skt hd M 8 x 15 mm (AP)	2	
-30	82024	. WASHER, Flat 8 4 mm (AP)	2	
-31	84233	. SCREW, Hex hd cap M 8 x 16 mm	3	
-32	84238	. WASHER, Flat 8 4 mm	3	
-33	69348	. NUT, Hex M 8 mm.....	3	
-34	69348	. NUT, Hex 8 4 mm.....	3	
-35	84238	. WASHER, Flat	3	
-36	84230	. COVER	1	
-37	84231	. SUPPORT.....	1	
-38	84240	. SUPPORT, Spacer.....	1	
-39	84241	. SUPPORT, Spacer.....	1	
-40	84233	. SCREW, Hex hd, M 8 x 16 mm	3	
-41	84238	. WASHER, Flat, 8 4 mm	3	
42	84227	. SCREW, Skt	4	
43	69494	. NUT, Hex, M 5 mm (AP).....	4	
-44	84238	. WASHER, Flat, 5 3 mm (AP)	4	
-45	84232	. SCREW, Skt hd M 8 x 15 mm	2	
46	82024	. WASHER, Flat 8 4 mm	2	
-47	84229	. COWLING, Fly wheel end	1	
-48	84291	. DUCT, Blower	1	
-49	84292	. SPACER, Duct	1	
-50	82495	. SCREW, Skt hd M 8 x 55 mm	2	
-51	84285	. OIL, Pipe, right	1	
-52	84290	. GASKET	1	
-53	84286	. OIL, Pipe, left	1	
-54	84288	. TUBE, Cooling	2	
-55	84289	. PACKING, Performed 20 3 x 2.4 mm	4	
-56	84297	. WASHER, Lock, split 8 mm	1	
-57	84293	. SCREW, Hex hd, M 6 x 20 mm	1	
-58	84294	. WASHER, Lock, Split, 6 mm	1	
-59	84287	. DUCF, Air.....	1	
8-71				

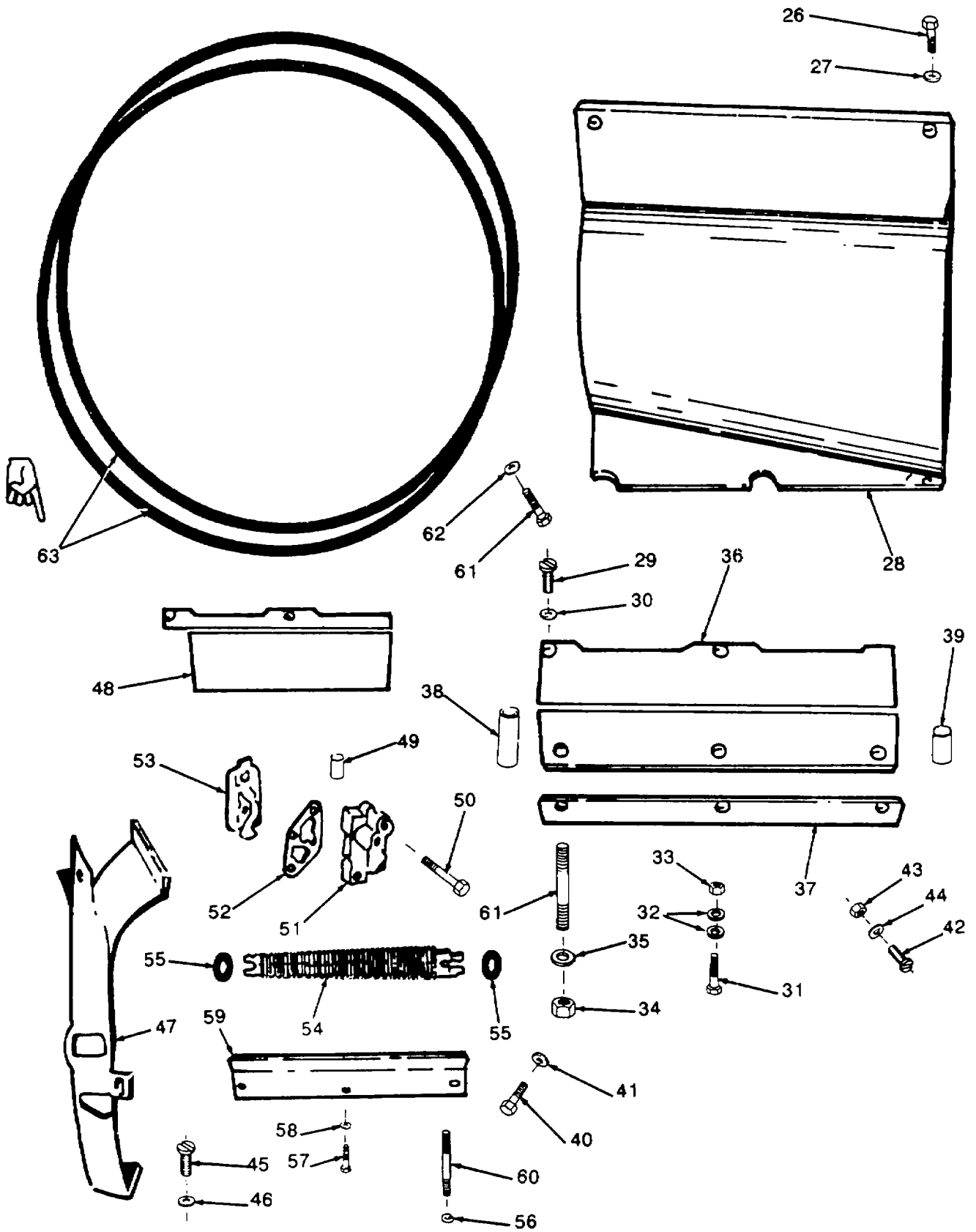

Figure 8-30. Blower Group (Sheet 9 of 10)
 Change 3 8-72

FIGURE & INDEX NUMBER	PART NUMBER	DESCRIPTION 1 2 3 4 5 6 7	QTY PER ASSY	USABLE ON CODE
-60 -61 -62 -63	84296 82058 82239 84242 (16004)	STUD, M 8 X 55 mm SCREW, Hex hd, M 6 x 10 mm WASHER, Flat, 6 4 mm V-BELT Set	3 3 2	
Change 3 8-73				

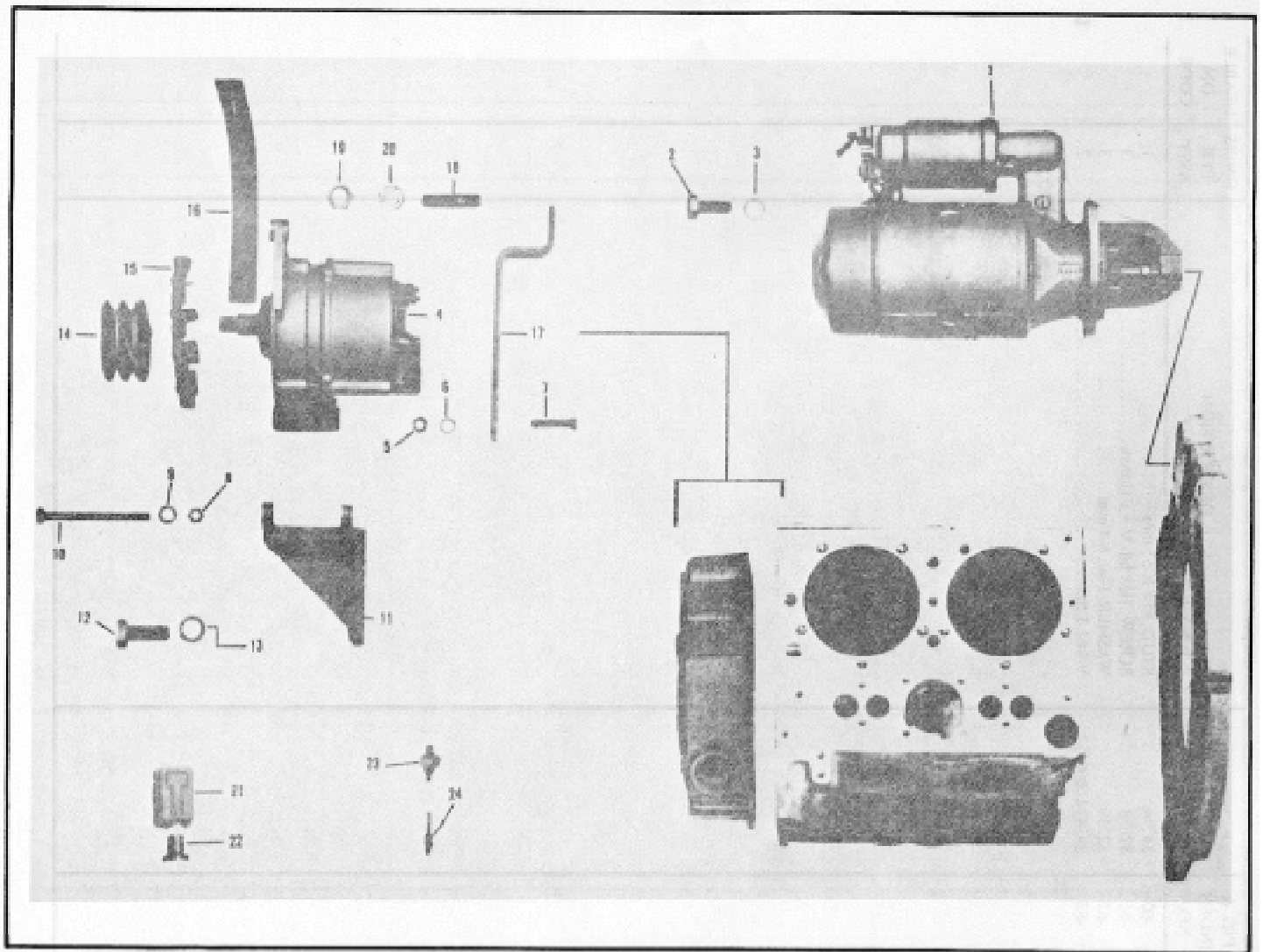

Figure 8-30. Engine Electrical Accessories (Sheet 10 of 10)

FIGURE & INDEX NUMBER	PART NUMBER	DESCRIPTION							QTY PER ASSY	USABLE ON CODE
		1	2	3	4	5	6	7		
8-30	No Number	ELECTRICAL ACCESSORIES, Engine.....							REF	
-1	84264	STARTER, Electrical, 12V.....							1	
-2	84266	SCREW, Hex hd, cap, M 12 x 30 mm (AP)							2	
-3	84265	WASHER, Lock, split, 12 mm (AP)							2	
-4	84267	ALTERNATOR, 3-Phase.....							1	
-5	69348	NUT, Hex M 8 mm (AP).....							1	
-6	84271	WASHER, Flat 8 4 mm (AP)							1	
-7	84278	SCREW, Hex hd M 8 x 35 mm							1	
-8	69348	NUT, Hex, M 8 mm (AP).....							1	
-9	84271	WASHER, Flat 8 4 mm (AP)							1	
-10	84269	SCREW, Hex hd cap M 8 x 90 mm							1	
-11	84268	SUPPORT, Alternator							1	
-12	84272	SCREW, Hex hd, cap, M 14 x 35 (AP)							2	
-13	84273	WASHER, Lock, split, 14 mm (AP)							2	
-14	84274	PULLEY, V-Belt.....							1	
-15	84275	FAN							1	
-16	84277	COVER, Fan							1	
-17	84276	ARM, Support.....							1	
-18	84334	STUD, M 12 mm							1	
-19	69523	NUT, Hex, M 12 mm.....							1	
-20	84043	WASHER, Lock, split 12 mm							1	
-21	84279	SWITCH, Glow-plug, start							1	
-22	84280	BUTTON, Plastic, glow plug, start							1	
-23	82323	SWITCH, Oil pressure.....							1	
-24	84305	SWITCH, Temperature.....							1	
8-75										

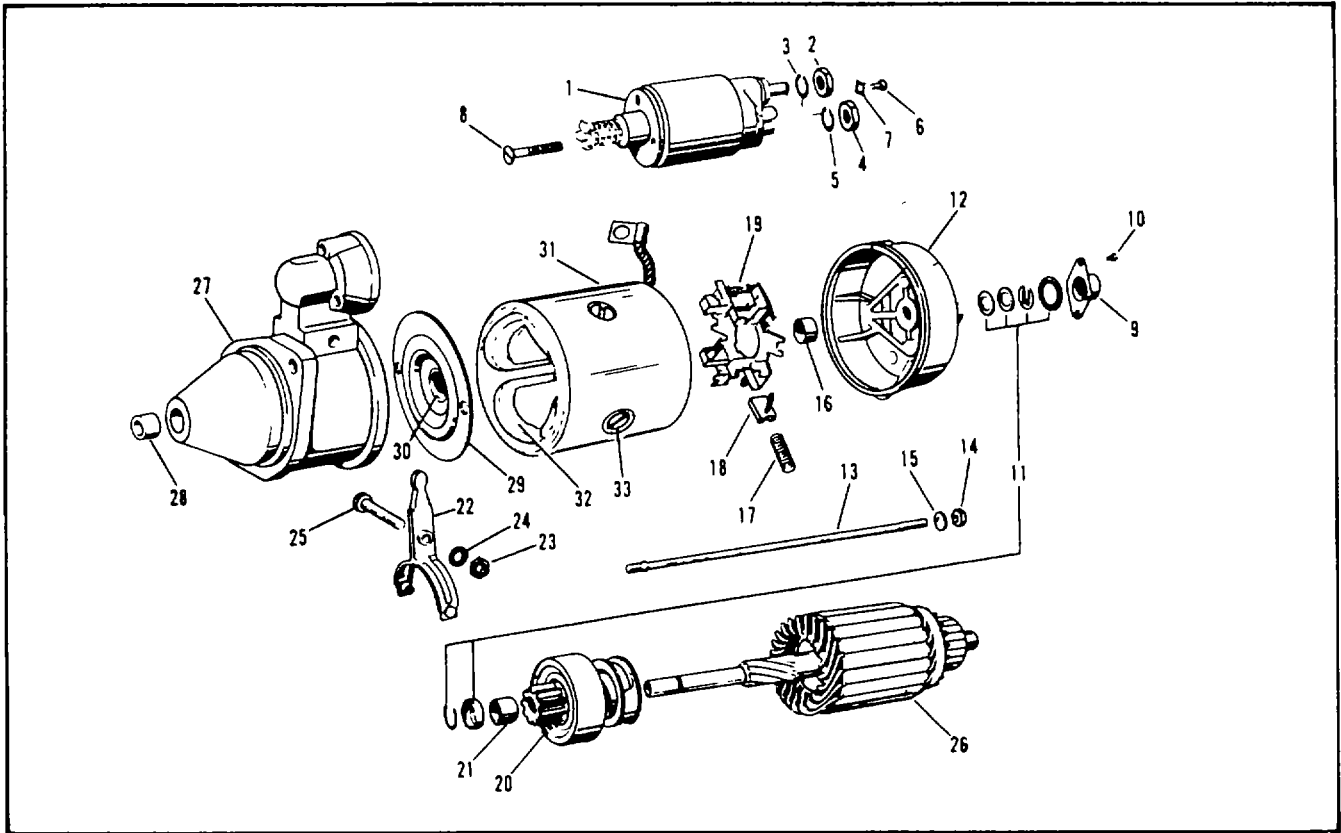

Figure 8-31. Starting Motor Subassembly

FIGURE & INDEX NUMBER	PART NUMBER	DESCRIPTION	QTY							USABLE ON CODE	
			1	2	3	4	5	6	7		PER ASSY
8-31	84264	MOTOR SUBASSY, Starting (see figure 8-30 for NHA)								REF	
-1	84316	. SWITCH, Solenoid									
-2	69565	. NUT, Hex								1	
-3	69564	. WASHER, Lock, split								1	
-4	84337	. NUT, Hex								1	
-5	69564	. WASHER, Lock, split								1	
-6	69562	. SCREW, Mach								1	
-7	82339	. CLAMP								1	
-8	69567	. SCREW, Mach								3	
-9	69568	. CAP, End cover								1	
-10	69569	. SCREW, Mach								2	
-11	82342	. KIT, Retainer								1	
12	84336	. COVER, End								1	
-13	69584	. STUD								2	
-14	69573	. NUT, Hex								2	
-15	69574	. WASHER, Flat								2	
-16	82336	. BEARING, Sleeve								1	
-17	69575	. SPRING, Brush								4	
-18	84338	. BRUSH SET, Carbon								1	
-19	84339	. HOLDER, Brush								1	
-20	84317	. PINION DRIVE								1	
-21	84318	. BEARING, Sleeve								1	
-22	82334	. LEVER								1	
-23	69581	. NUT, Hex (AP)								1	
-24	69580	. WASHER, Lock, split (AP)								1	
-25	84319	. SCREW, Cap, hex hd, (AP)								1	
-26	84320	. ARMATURE								1	

FIGURE & INDEX NUMBER	PART NUMBER	DESCRIPTION 1 2 3 4 5 6 7	QTY PER ASSY	USABLE ON CODE
-27	84321	FRAME, Drive end	1	
-28	84322	BEARING, Sleeve	1	
-29	84340	BEARING, Intermediate	1	
-30	84341	BEARING, Sleeve	1	
-31	No Number	HOUSING, Winding.....	1	
-32	84342	WINDING, Excitation.....	1	
-33	69591	SCREW, Pole	4	
8-77				

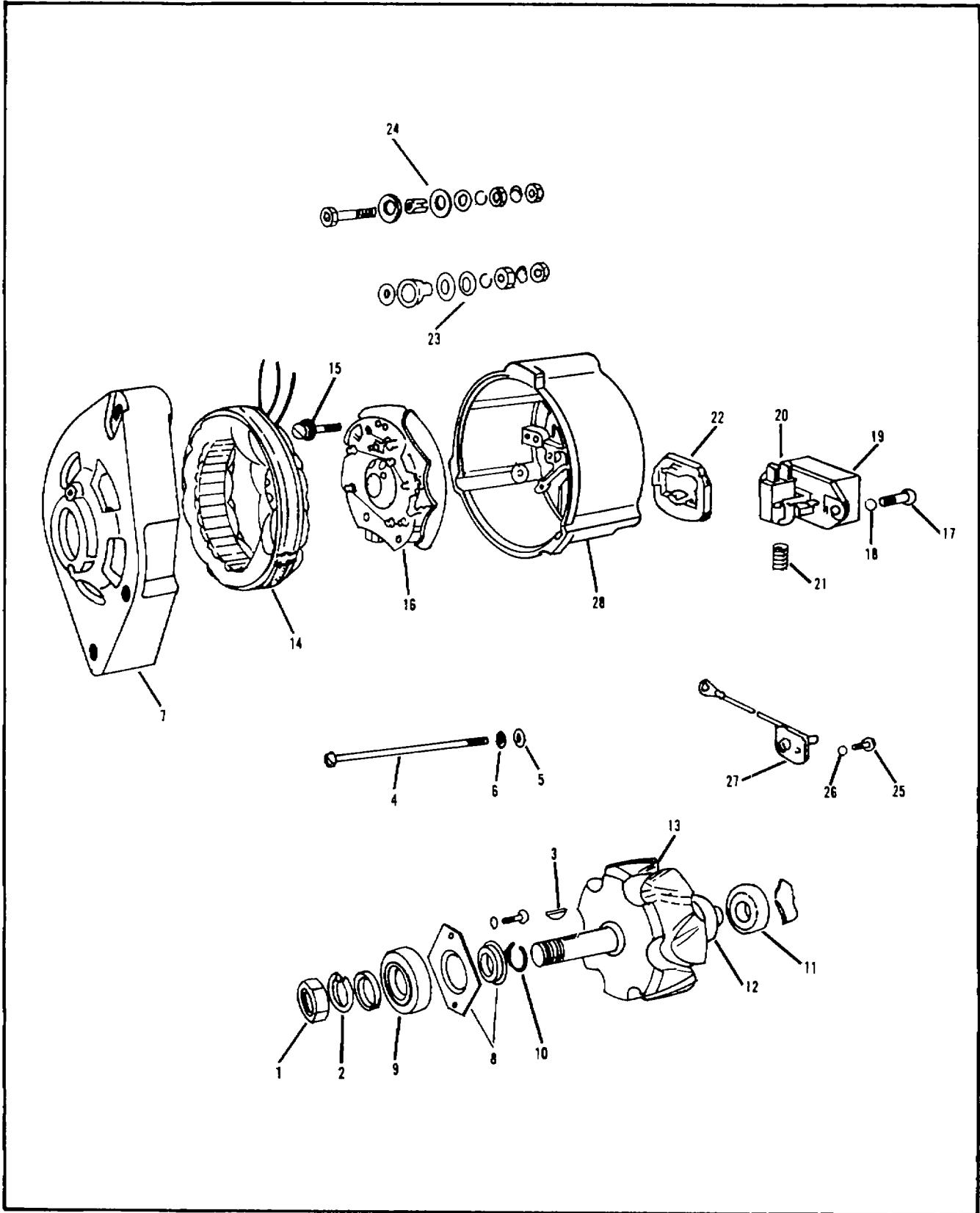

Figure 8-32. Alternator
8-78

FIGURE & INDEX NUMBER	PART NUMBER	DESCRIPTION							QTY PER ASSY	USABLE ON CODE	
		1	2	3	4	5	6	7			
832	84267	.									
		.									
		.									
-1	84344	.									
-2	84345	.									
-3	84346	.									
4	84347	.									
-5	84348	.									
-6	84349	.									
-7	84350	.									
-8	84351	.									
-9	84355	.									
-10	84354	.									
-11	84356	.									
-12	84359	.									
-13	84358	.									
-14	84357	.									
-15	84360	.									
-16	84361	.									
-17	84362	.									
-18	84363	.									
-19	84364	.									
-20	84365	.									
-21	84366	.									
-22	84367	.									
-23	84368	.									
-24	84369	.									
-25	84370	.									
-26	84371	.									
-27	84372	.									
-28	84387	.									

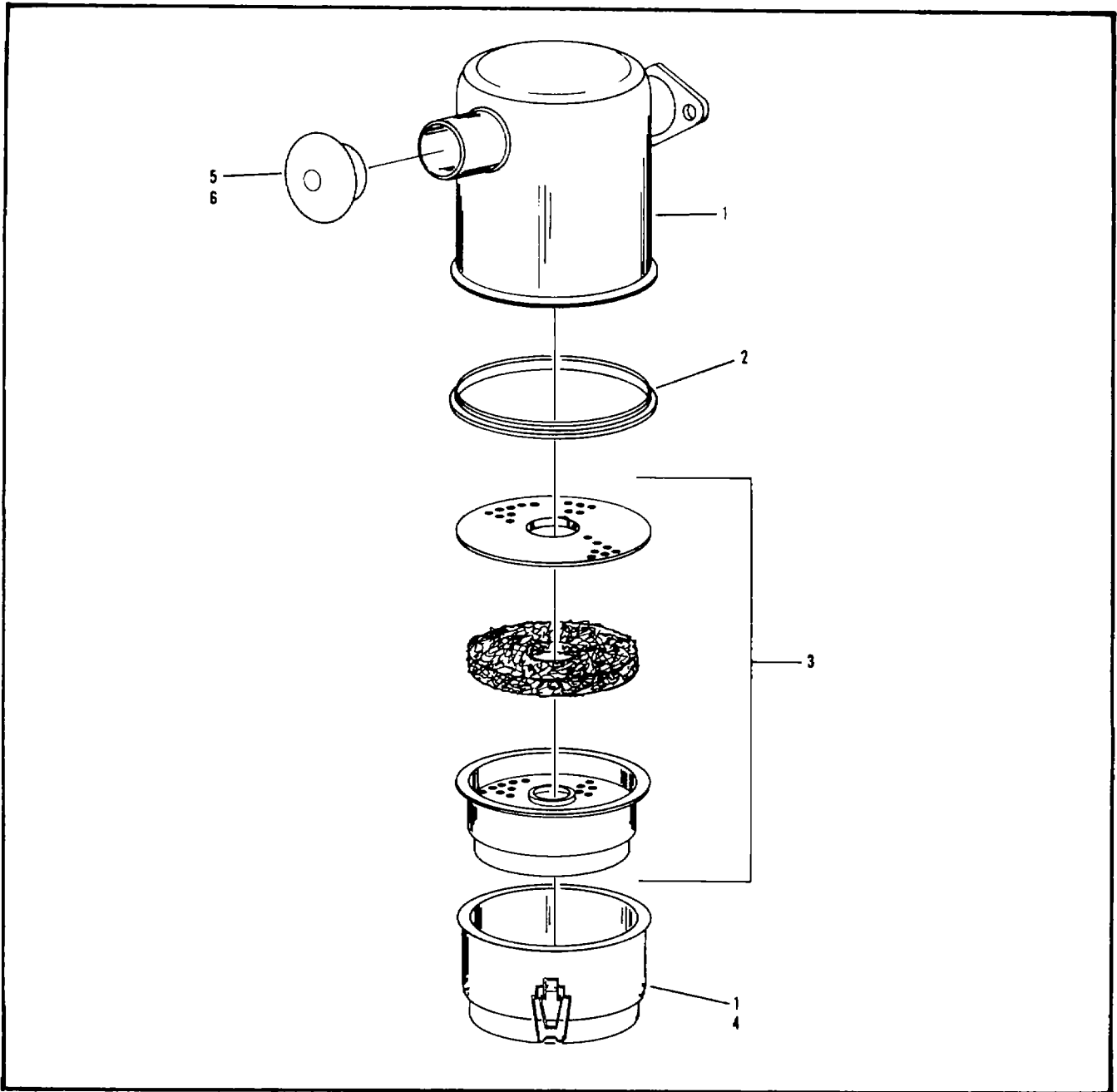

Figure 8-33. Engine Air Filter

FIGURE & INDEX NUMBER	PART NUMBER	DESCRIPTION	QTY PER ASSY	USABLE ON CODE
8-33	84256	AIR FILTER, Engine oil bath (see figure 8-30, sheet 1 of 10 for NHA).....	REF	
-1	84381	. CONTAINER, Oil	1	
-2	84382	. SEAL, O-ring, external.....	1	
-3	84383	. FILTER, Element assy.....	1	
-4	84384	. SEAL, Internal.....	1	
-5	84385	. CAP, Ran.....	1	
-6	84386	. STRAP, Rain Cap.....	1	

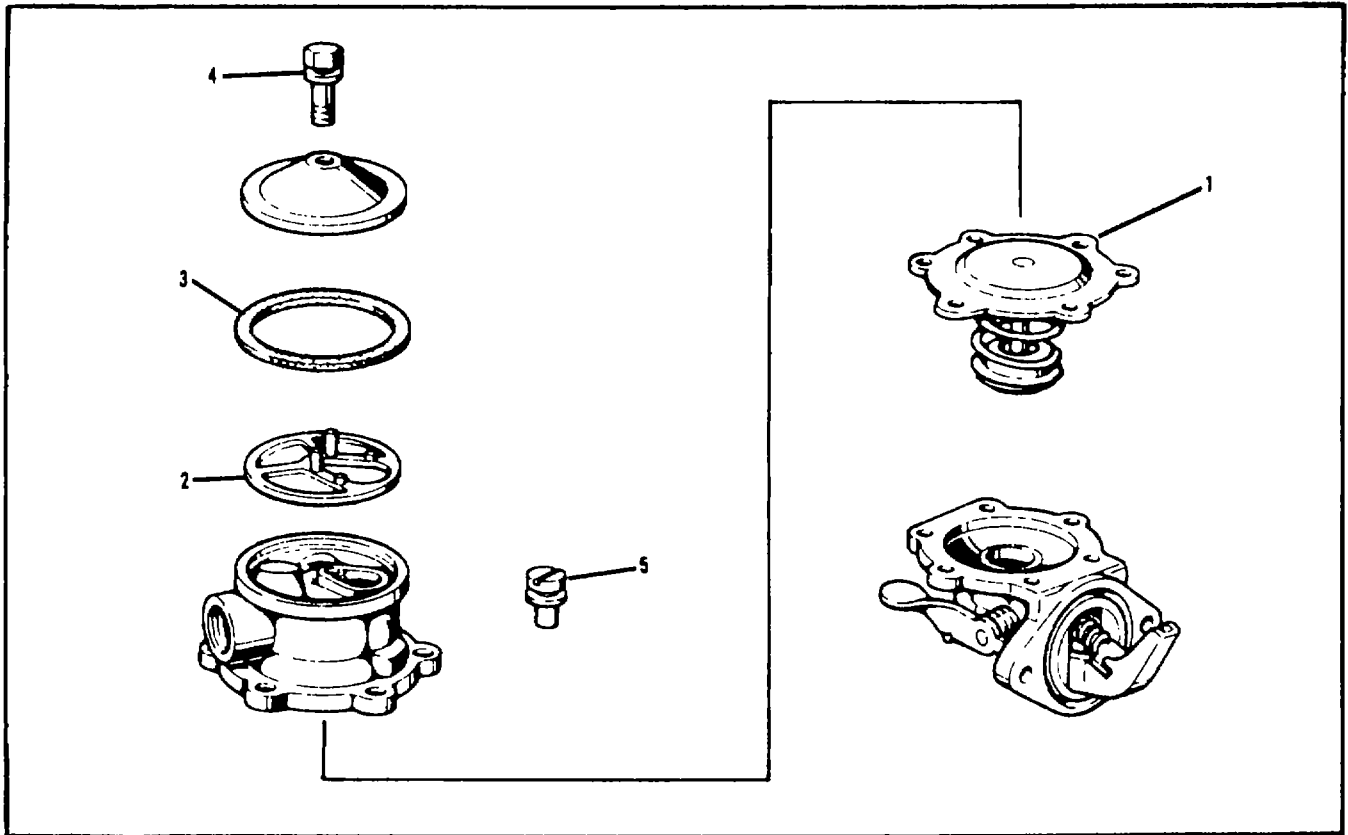

Figure 8-34. Fuel Feed Pump Assembly

FIGURE & INDEX NUMBER	PART NUMBER	DESCRIPTION							QTY PER ASSY	USABLE ON CODE
		1	2	3	4	5	6	7		
8-34	84298	PUMP, Fuel feed (see figure 8-30, sheet 1 of 10 for NHA)							1	
-1	84309	Diaphragm							1	
-2	84312	Fuel filter							1	
-3	84310	GASKET							1	
-4	84311	GASKET							1	
-5	84308	ALL, Screw							6	

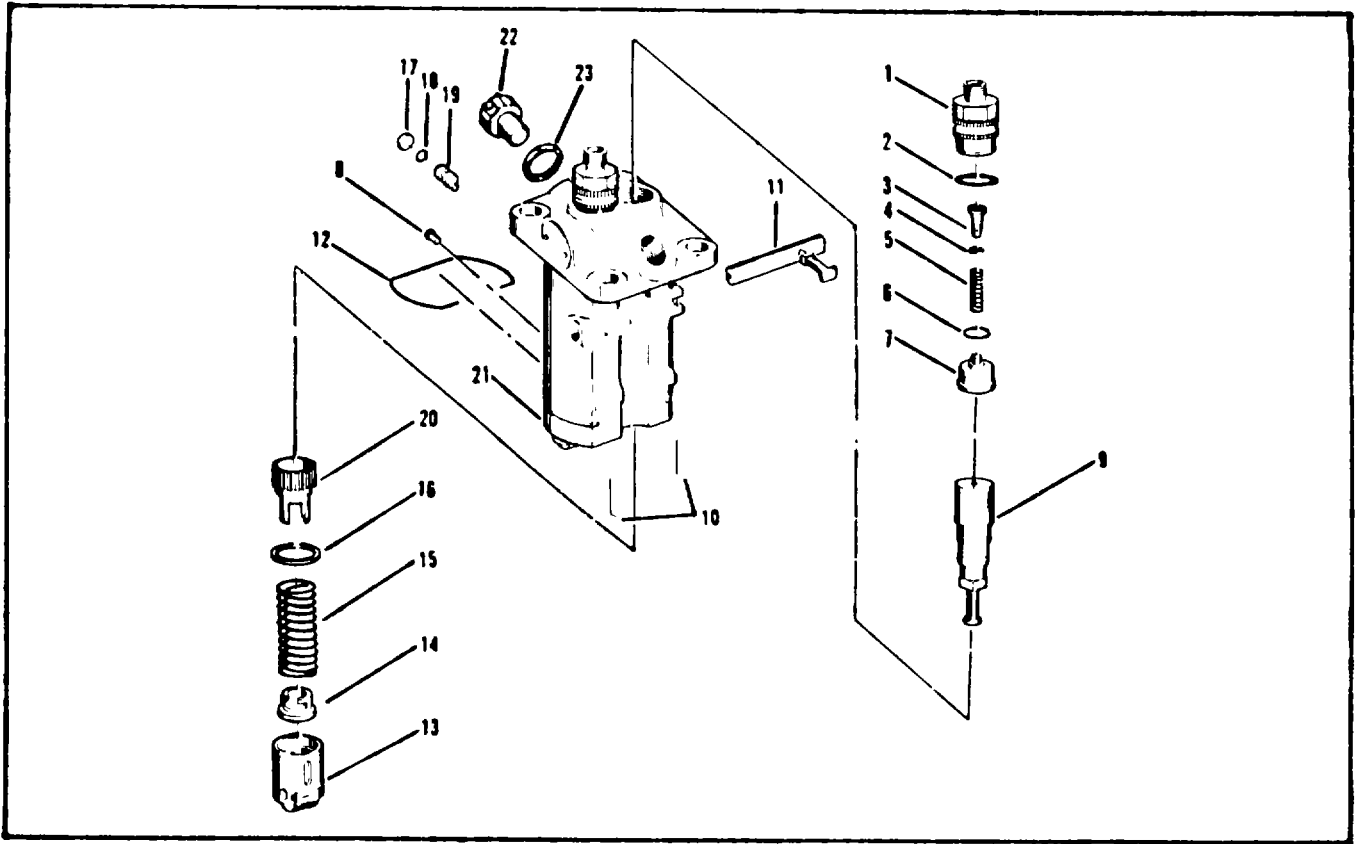

Figure 8-35. Fuel Injection Pump Subassembly

FIGURE & INDEX NUMBER	PART NUMBER	DESCRIPTION	QTY PER ASSY							USABLE ON CODE	
			1	2	3	4	5	6	7		
8-35	84143	PUMP SUBASSY, Fuel injection (see figure 8-30, sheet 1 of 10 for NHA)								REF	
-1	82377	. HOLDER, Delivery valve.....								2	
-2	82382	. PACKING, Performed, ring.....								2	
-3	82379	. PIECE Filling.....								2	
4	82380	. SHIM.....								2	
-5	82378	. SPRING, Delivery valve.....								2	
-6	82381	. GASKET, Copper.....								2	
-7	82376	. VALVE, Delivery								2	
-8	82390	. PIN, Guiding								2	
-9	84313	. ELEMENT, Pump.....								2	
-10	82392	. PIN 2.....								2	
-11	84314	. RACK, Control								1	
-12	82391	. RING, Locking								1	
-13	82389	. TAPPET, Roller.....								2	
-14	82385	. SPRING PLATE Lower								2	
-15	82386	. SPRING, Plunger.....								2	
-16	82384	. SPRING PLATE Upper								2	
-17	82383	. PLUG								1	
-18	82393	. PACKING, Performed, o ring								1	
-19	82394	. PIN Eccentric.....								1	
-20	82388	. SLEEVE, Control								2	
-21	No Number	. BODY, Pump (NPS).....								1	
-22	84373	. PLUG, Screw								1	
-23	84374	. GASKET								1	

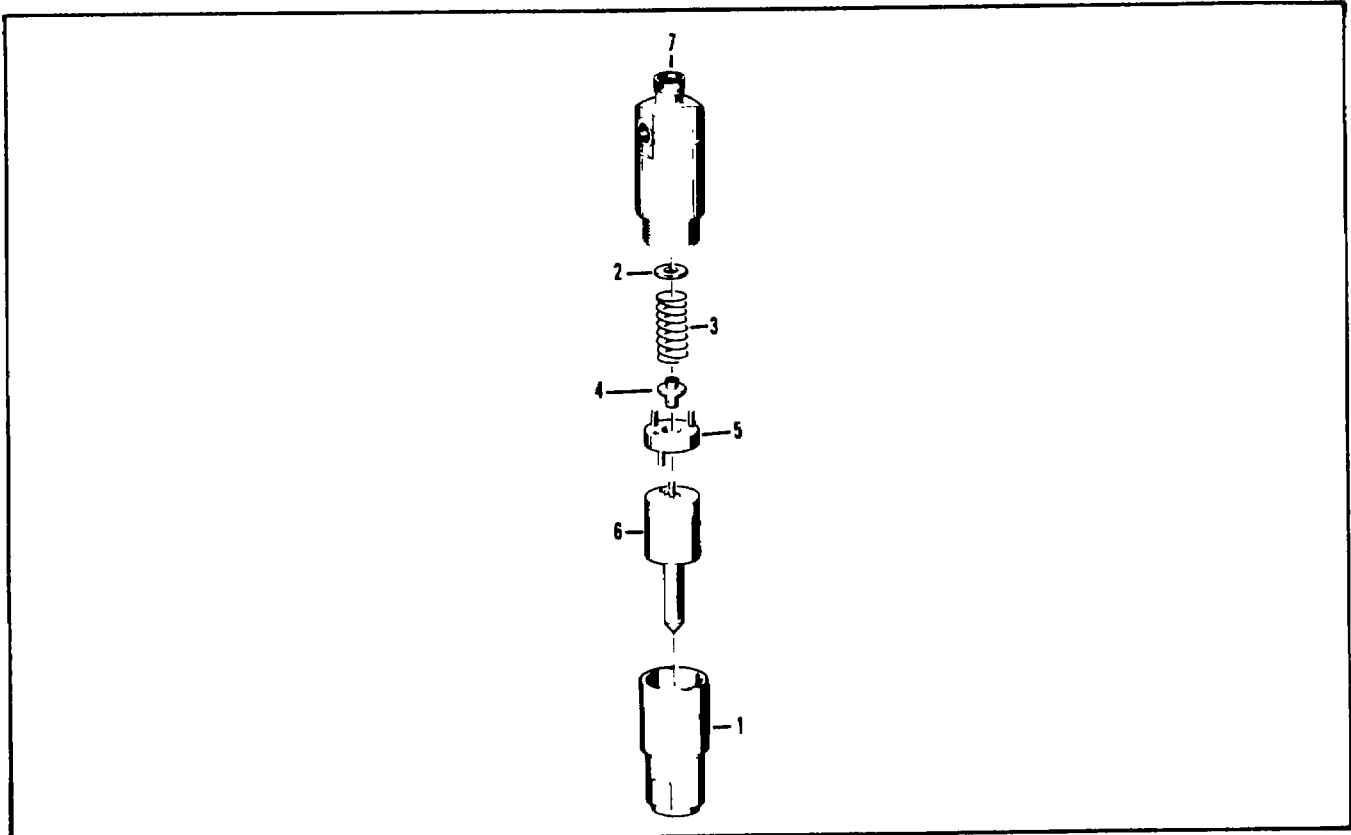

Figure 8-36. Fuel Injector Subassembly

FIGURE & INDEX NUMBER	PART NUMBER	DESCRIPTION	QTY PER ASSY	USABLE ON CODE
8-36	84144	INJECTOR SUBASSY, Fuel (see figure 8-30, sheet 1 of 10 for NHA)	REF	
-1	82208	. NUT, Retainer	1	
-2	82212	. SHIM, 1 00 mm thk	AR	
	82213	. SHIM, 1 05 mm thk	AR	
	82214	. SHIM, 1 10 mm thk	AR	
	82215	. SHIM, 1.15 mm thk	AR	
	82216	. SHIM, 1 20 mm thk	AR	
	82217	. SHIM, 1 25 mm thk	AR	
	82218	. SHIM, 1 30 mm thk	AR	
	82219	. SHIM, 1 35 mm thk	AR	
	82220	. SHIM, 1 40 mm thk	AR	
	82221	. SHIM, 1 45 mm thk	AR	
	82222	. SHIM, 1 50 mm thk	AR	
	82223	. SHIM, 1 55 mm thk	AR	
	82224	. SHIM, 1 60 mm thk	AR	
	82225	. SHIM, 1 65 mm thk	AR	
	82226	. SHIM, 1 70 mm thk	AR	
	82227	. SHIM, 1 75 mm thk	AR	
	82228	. SHIM, 1 80 mm thk	AR	
	82229	. SHIM, 1 85 mm thk	AR	
	82230	. SHIM, 1 90 mm thk	AR	
	82231	. SHIM, 1 95 mm thk	AR	
-3	82211	. SPRING, Pressure	1	
-4	82210	. SPINDLE, Pressure	1	
-5	82209	. DISC, Intermediate	1	
-6	82203	. NOZZLE	1	
-7	No Number	. HOLDER, Nozzle, KBAL 107 S9/13	1	

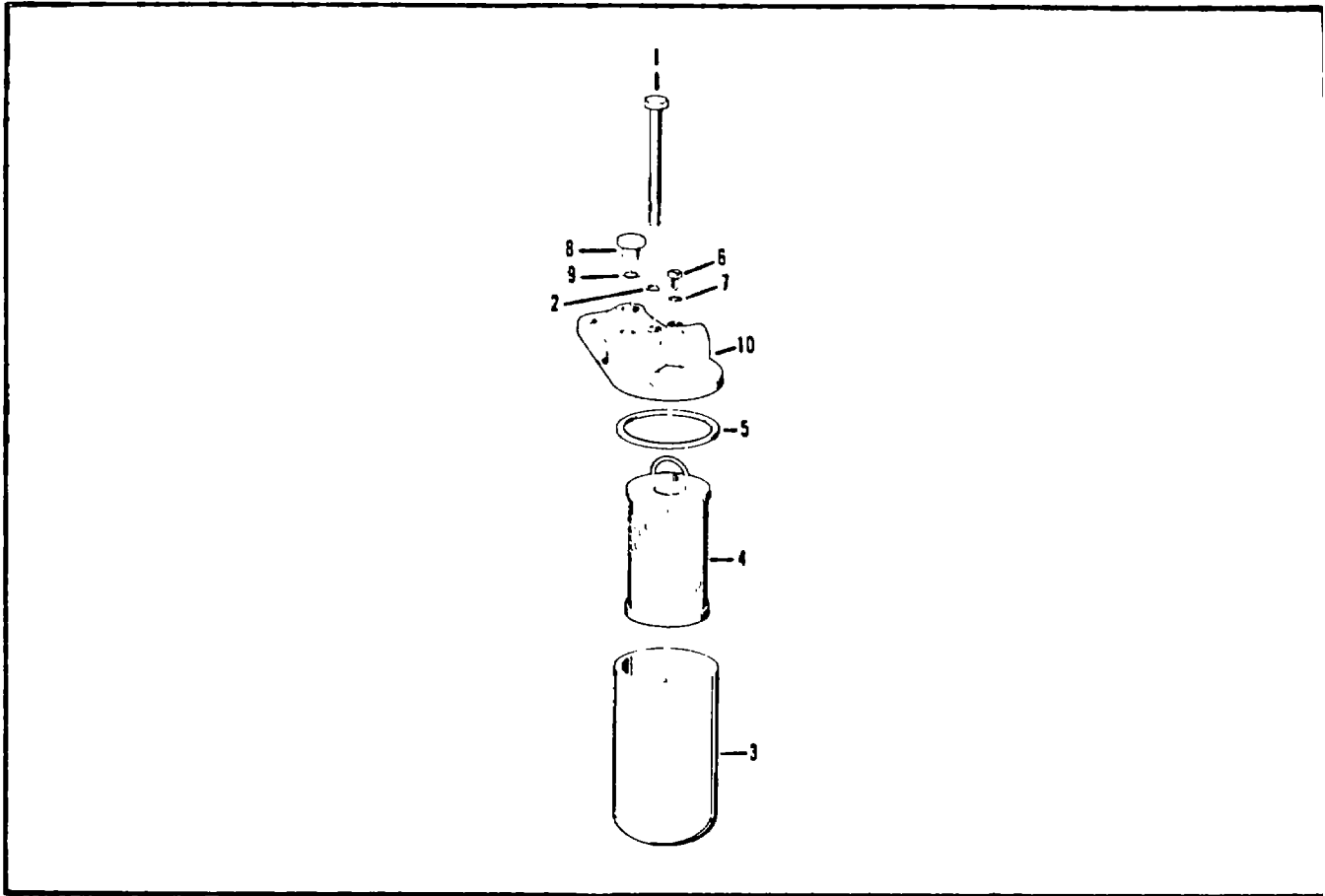

Figure 8-37. Fuel Filter Subassembly

FIGURE & INDEX NUMBER	PART NUMBER	DESCRIPTION							QTY PER ASSY	USABLE ON CODE
		1	2	3	4	5	6	7		
8-37	82266	FILTER SUBASSY, Fuel (see Figure 42-74 for NHA)							REF	
-1	No Number	.	SCREW, Cap, hex hd, 8 x 75 mm lg						1	
-2	82399	.	GASKET, Copper.....						1	
-3	No Number	.	HOUSING, FILTER (NPS)						1	
-4	82267	.	ELEMENT, FILTER						1	
-5	82268	.	PACKING,.....Performed, o-ring						1	
-6	No Number	.	VALVE, Bleed						1	
-7	82399	.	GASKET, Copper.....						1	
-8	No Number	.	PLUG Pipe, hex hd, 1/4 x 18 mm lg						1	
-9	82340	.	GASKET, Copper.....						1	
-10	No Number	.	FLANGE, Filter						1	

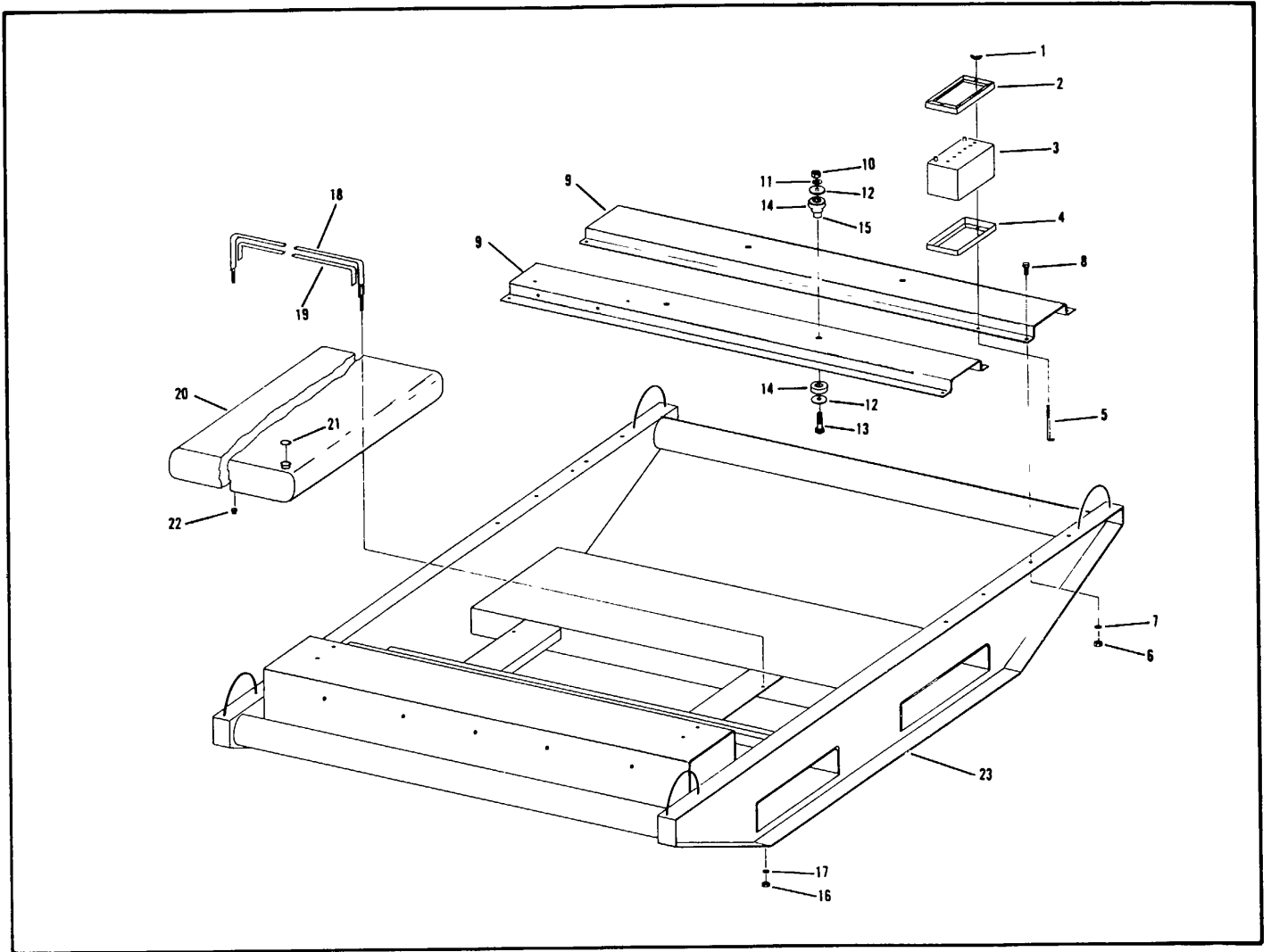

Figure 8-38. Frame Group
8-85

FIGURE & INDEX NUMBER	PART NUMBER	DESCRIPTION 1 2 3 4 5 6 7	QTY PER ASSY	USABLE ON CODE
8-38	No Number	FRAME GROUP	REF	
-1	126032	WING NUT, 3/8-16 (24617)	2	
-2	BH25M	RETAINER, Battery (04055) (44540).....	1	
-3	69688	BATTERY, Storage, 12 volt 84 amp	1	
-4	83999	SUPPORT, Battery	1	
-5	65578	BOLT- J, Battery mount	2	
-6	272683	NUT, Lock, 7/16-14 (24617)	8	
-7	120395	WASHER, Flat, 7/16 (24617)	8	
-8	122267	SCREW, Hex hd, cap, 7/16-14 x 1-1/4 (24617)	8	
-9	83340	SUPPORTS, Engine	2	
-10	443339	NUT, Hex, self-locking, 1/2 x 13 (24617)	4	
-11	120396	WASHER, Flat, 1/2" (24617)	4	
-12	80054	WASHER, Special	8	
-13	122513	SCREW, Hex, 1/2- 13 x 4" (24617)	4	
-14	84693	MOUNT, Shock, engine	4	
-15	80265	SLEEVE, Shock mount	4	
-16	120377	NUT, Hex, 3/8-16 (24617).....	2	
-17	120382	WASHER, Lock, 3/8 (24617)	2	
-18	66399	STRAP, Fuel tank	1	
-19	14048	WEBBING, Strap 39"	1	
-20	83331	TANK, Fuel	1	
	40319	ELBOW, Street 3/ 8	1	
	116332	BUSHING, Reducer 3/8" x 1/4" (24617)	1	
	42233	SHUT-OFF COCK	1	
-21	2302J017	CAP, Fuel tank (78252)	1	
-22	143935	PLUG, Dram, 1/2 sq hd	1	
-23	83334	SKID, Compressor unit	1	

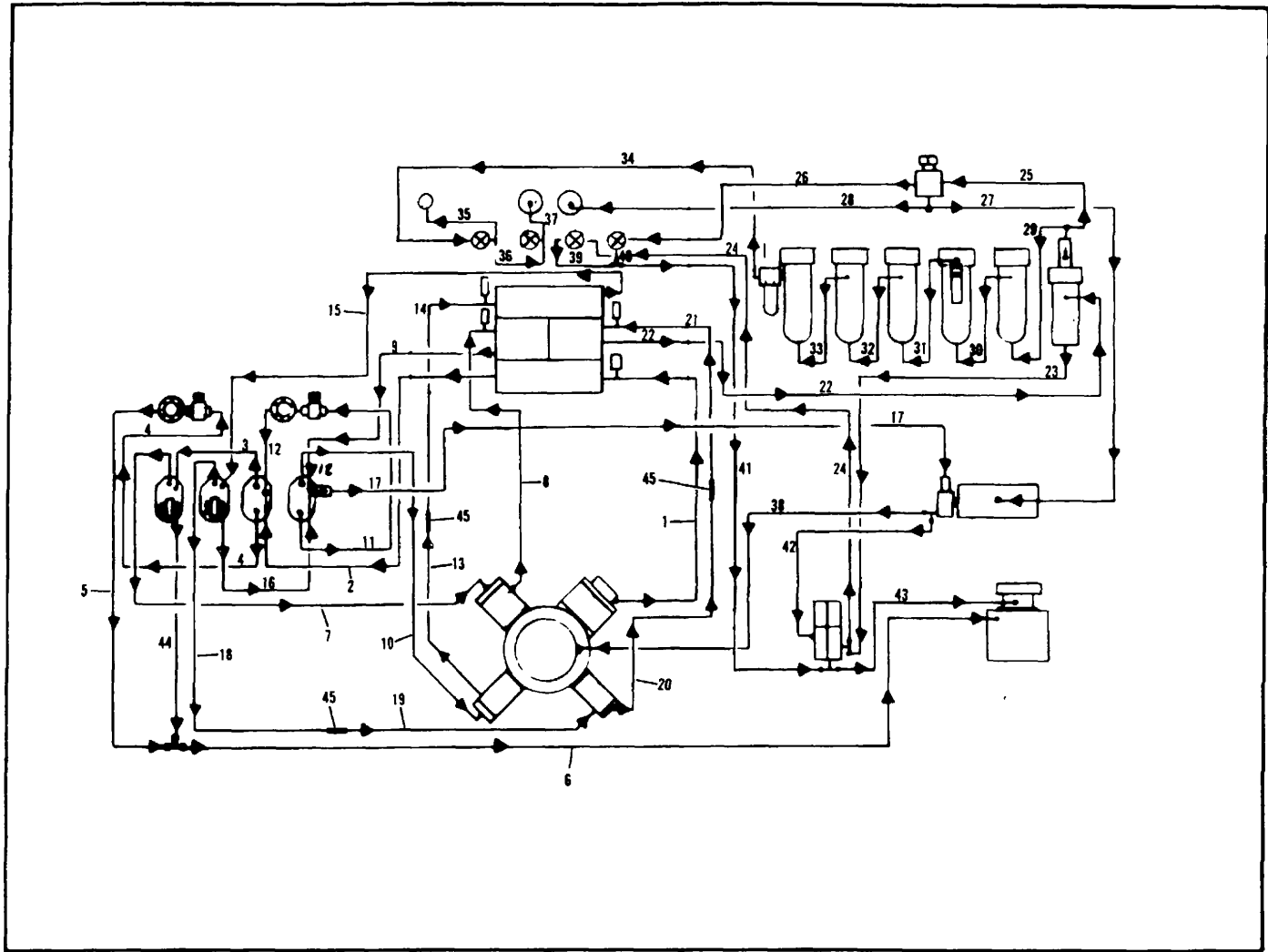

Figure 8-39. Tubing Identification

FIGURE & INDEX NUMBER	PART NUMBER	DESCRIPTION	QTY PER ASSY	USABLE ON CODE
8-39	No Number	TUBING IDENTIFICATION.....	REF	
-1	69750	. HOSE ASSY, Flex, 1st stage ca1 to air cooler inlet.	1	
-2	84873	. TUBE ASSY, 1st stage air cooler outlet to . 1st stage trap.....	1	
-3	84886	. HOSE ASSY, 1st stage trap to accumulator.....	1	
-4	44361	. HOSE ASSY, 1st stage to 1st stage bleed valve.....	1	
-5	84998	. HOSE ASSY, 1st stage bleed valve to tee.....	1	
-6	50953	. HOSE, Tee to condensate receiver.....	1	
-7	69750	. HOSE ASSY, Flex, accum to 2nd stage inlet.....	1	
-8	69748	. HOSE ASSY, Flex, 2nd stage cal outlet to2 nd stage air cooler melt.....	1	
-9	84881	. TUBE ASSY, 2nd stage air cooler outlet to 2 nd stage trap.....	1	
-10	69748	. HOSE ASSY, Flex, 2nd stage trap to 3rd stage ca1 inlet.....	1	
-11	44361	. HOSE ASSY, 2nd stage trap to 2nd stage bleed valve.....	1	
-12	45331	. HOSE ASSY, 2nd stage bleed valve to 2st stage trap.....	1	
-13	84880	. TUBE ASSY, 3rd stage ca1 outlet to union.....	1	
-14	69747	. HOSE ASSY, Flex, union to 3rd stage air cooler inlet.....	1	
-15	84874	. TUBE ASSY, 3rd stage air cooler outlet to 3rd stage trap.....	1	
-16	84896	. TUBE ASSY, 3rd stage trap to 2nd stage trap.....	1	
-17	45331	. HOSE ASSY, 2nd stage trap to solenoid valve.....	1	
-18	69748	. HOSE ASSY, Flex, 3rd stage trap to union.....	1	
-19	84882	. TUBE ASSY, Union to 4th stage ca1 inlet.....	1	
-20	82466	. TUBE ASSY, Finned, 4th stage ca1 to union connector.....	1	
-21	81713	. HOSE ASSY, Flex, Union connector to 4th stage air cooler inlet.....	1	
-22	84875	. TUBE ASSY, 4th stage air cooler outlet to mech. filter.....	1	
-23	84919	. TUBE ASSY..... Mechanical fitter to drain valve		
-24	84892	. TUBE ASSY, Drain valve to mech. filter bleed valve		
-25	84893	. TUBE ASSY, Check valve tee to rupture disc.....	1	
-26	84698	. TUBE ASSY, Rupture disc to dehydr bleed valve ...	1	
-27	66288	. HOSE ASSY, Rupture disc to unloader box.....	1	
-28	84697	. TUBE ASSY, Rupture disc to M/F pressure gauge .	1	
-29	84878	. TUBE ASSY, Check valve tee to dehydrator No 1...		
-30	84883	. TUBE ASSY, Dehydrator No 1 to dehydrator No 2...	1	
-31	84887	. TUBE ASSY, Priory valve to air purification ca1 No 3	1	
-32	84883	. TUBE ASSY, Air purification ca1 No 3 to air purification ca1 No 4.....	1	
-33	84889	. TUBE ASSY, Air purification ca1 No 4 to air purification ca1 No 5.....	1	
-34	84888	. TUBE ASSY, Air purification ca1 No 5 to service valve.....	1	
-35	84690	. TUBE ASSY, Service valve to service outlet.....	1	
-36	84692	. TUBE ASSY, Service valve to service bleed valve..	1	
-37	84691	. TUBE ASSY, Service bleed valve to service pressure gauge.....	1	
-38	44359	. HOSE ASSY, Solenoid valve to air compressor.....	1	
-39	84890	. TUBE- ASSY, M/I bleed valve to tee.....	1	
-40	85442	. TUBE ASSY, Dehydrator bleed valve to tee		
-41	85292	. TUBEASSY, Tee to drain valve		
-42	47270	. HOSE ASSY, Solenoid to drain valve.....	1	
-43	84891	. TUBE ASSY..... Dram valve to condensate receiver		
-44	84898	. HOSE ASSY, Accum bleed valve to condensate receiver drain line tee.....	1	
-45	29351	. CONNECTOR, Union.....	3	
		8-88		

CHAPTER II

**MANIFOLD SERVICING UNIT, CASCADE
COMPRESSED GAS, AIR,
TRAILER MOUNTED, TYPE I
PART NUMBER 83208 (16004).....1-1**

**MANIFOLD SERVICING UNIT, DUAL
AIR/OXYGEN
TRAILER MOUNTED, TYPE II
PART NUMBER 83209 (16004).....1-1**

WARNING

Disregard of the warnings below will be hazardous to your health and life.

- 1 Oxygen clean all parts prior to installing in an oxygen system.
- 2 Do not allow oxygen system to become contaminated. If there is the least doubt that the oxygen section of the Type II Servicing Unit is not clean, do not use the system until it has been recleaned
- 3 Do not interchange Air and Oxygen Parts
- 4 Do not use a petroleum base cleaning agent on any part of an oxygen system
- 5 Do not allow any fire or smoking within the area of the oxygen use or storage. Post NO SMOKING/NO FIRE signs during the period the oxygen system is being charged, stored or in use
- 6 Fire suppression equipment of the proper size and type shall be Immediately available during use, movement, or storage of charged oxygen equipment
7. High pressure air or oxygen is dangerous, do not direct air or oxygen stream toward body Serious injury or death may result from high pressure gas entering the skin
- 8 Do not operate the Type I or Type II Servicing Units without first making sure that the proper cartridges are installed In the purification cylinders. Insure the cartridges are not contaminated
- 9 Inspect the Service Units flex servicing hoses and yoke adapters before and after each use
10. Do Not disconnect ANY service hose (flex line) without first making sure no pressure Is In the line

a/(b Blank)

**CHAPTER II
TABLE OF CONTENTS**

Section/ Para	Page	Section/ Para	Page
I. INTRODUCTION AND GENERAL INFORMATION.....	1-1	4-7 Operation Instructions	4-5
1-1 Introduction	1-1	V. MAINTENANCE INSTRUCTIONS.....	5-1
1-2 General Information	1-1	5-1 General	5-1
1-3 Description	1-1	5-2 Inspection and Preventative Maintenance.....	5-1
1-9 Consumable Material	1-1	5-3 Lubrications Instructions.....	5-2
II. SPECIAL TOOLS AND TEST EQUIPMENT.....	2-1	5-4 Troubleshooting	5-2
2-1 General		VI. REPAIR INSTRUCTIONS.....	6-1
2-2 Special Tools and Test Equipment	2-1	6-1 Repair	
III. PREPARATION FOR USE AND SHIPMENT		6-1	
3-1		6-3 Air Compressor Unit	6-1
3-1 General	3-1	6-4)Disassembly of Major Components....	6-4
3-2 Preparation for Use.....		6-10 Test	6-14
3-1		VII. ILLUSTRATED PARTS BREAKDOWN ...	7-1
3-3 Preparation for Storage or Shipment ..	3-1	7-1 General.....	7-1
IV. OPERATION INSTRUCTIONS	4-1	7-2 Maintenance Parts List.....	7-1
4-1 General	4-1		
4-2 Theory of Operation	4-1		

LIST OF ILLUSTRATIONS

Figure	Page	Figure	Page
1-1 Servicing Unit, Type I and Type II.....	1-3	7-2 Air Purification Cylinder Group, Type I ..	7-7
4-1 Operating Controls and Indicators (Type I) (Air).....	4-2	7-3 Oxygen Purification Cylinder Group, Type II	7-8
4-2 Operating Controls and Indicators (Type II) (Air/Oxygen)	4-3	7-4 Control Panel, Air, Type I (Sheet 1 of 2) (Front).....	7-9
4-3 Component Layout, Type I (Air)	4-6	7-4 Control Panel, Air, Type I, (Sheet 2 of 2) (Rear).....	7-11
4-4 Component Layout, Type II (Air/Oxygen) ..	4-8	7-5 Control Panel Assembly, Air/Oxygen, Type II (Sheet 1 of 2) (Front)	7-13
4-5 Cylinder Locations, Bulkhead (Panel View).....	4-10	7-5 Control Panel Assembly, Air/Oxygen, Type II (Sheet 2 of 2) (Rear)	7-15
5-1 Purification Cylinder	5-2		
7-1 Servicing Units, Type I and Type II	7-4		

LIST OF TABLES

Number	Page	Number	Page
1-1 Table of Leading Particulars	1-2	5-1 Inspection Checks and Services ...	5-1
		5-2 Troubleshooting.....	5-3

CHAPTER II

SECTION I.

INTRODUCTION AND GENERAL INFORMATION

1-1. INTRODUCTION: This chapter contains operation and maintenance instructions with illustrated parts break-down for the Type I, Manifold Servicing Unit, Air Part Number 83208, and Type II, Manifold Servicing Unit, Dual Air/Oxygen, Part Number 83209. Leading features of the Servicing Units (Type I and Type II) are listed in Table 1-1. Type I and Type II Manifold Servicing Units are as shown in Figure I-1, and hereafter shall be referred to as Servicing Unit, Air (Type I) or Servicing Unit, Air/Oxygen (Type II).

1-2. GENERAL INFORMATION. The Servicing Units (Type I and Type II) are mounted on Government Furnished M116A1, 3/4 Ton, 2 Wheel Chassis Trailers. Each trailer assembly is designed to carry eight high pressure supply cylinders that are to be used in recharging one to four scuba cylinders at the same time. Operating temperature range of the Servicing Units is -250F to 120°F (-320 to 490C). The Servicing Unit, Air (Type I) is designed to carry eight 3500 psi compressed gas cylinders for breathable air use. The Servicing Unit, Air/Oxygen (Type II) is designed to carry four 3500 psi compressed gas cylinders of breathable air and four 2260 psi compressed gas cylinders for breathable oxygen use. The Servicing Units are air transportable and are designed to operate under extreme climatic conditions.

1-3. DESCRIPTION. The Servicing Units (Type I and Type II) consist of the housing group, the control panel group, the air purification cylinder group and the welded frame group (See Figure 1-1.)

1-4. HOUSING GROUP (1, Figure 1-1). The housing group consists of a top cover, side covers, left and right hand doors, an undershield and a tool box. The housing components are attached to the welded frame, and provides protection for the control panel group and cylinder valves.

1-5. COMPRESSED GAS CYLINDERS (2, Figure I-1) These cylinders are used to either store breathable air on the Type I (Air) Servicing Units, or a combination of breathable air and oxygen on the Type II (Air/Oxygen) Servicing Units.

1-6. CONTROL PANEL ASSEMBLIES (Type I and Type II). The control panel is located behind the doors of the servicing unit, (see 1, Figure 1-1) The control panels are configured to allow the charging of one to four scuba cylinders. The control panels are attached to the welded frame assembly.

1-7. AIR PURIFICATION CYLINDER GROUP (Type I and Type II). The purification cylinders are located within the breathable air system or oxygen system so that a final filtering of the air or oxygen is provided before it enters into the scuba tanks. Access to the purification cylinders is through the hinged top cover of the housing group. The purification cylinders are attached to the welded frame assembly.

1-8. WELDED FRAME ASSEMBLY (7, Figure 1-1). The welded frame provides the mounting base for all the components of the Servicing Units (Type I and Type II). The service troughs, stabilizing jack, control panel, fender assemblies and housing group attach directly to the welded frame. The mounts directly onto the Government furnished M116A1 3/4 Ton Trailer.

1-9. CONSUMABLE MATERIALS. Consumable materials as pertain to the Government Furnished M116A1 3/4 Ton Trailer are as specified in TM9-2330-202-14P. Consumable materials for the Type I and Type II Servicing Units follows:

Nomenclature	Material	Specification Number	Government Std.	Davey Part Number
Air/Oxygen Purification Cartridge Cleaning* Detergent	Cartridge Solvent P-D-220	MILC-26058 P-D-680, Type II	MA-2	14048
Fittings (leak proofing)* Tubing and Fittings (joining)* Fabric, Cushioning	Tape, Antiseize Sealing Webbing	MIL-T-27730		
Fittings (leak proofing)** Tubing and Fittings (joining)**	Tape, Virgin Teflon Sealing-Dupont Krytox (fluorinated grease)			

*Type I only

**Type I and Type II

Table 1-1. Table of Leading Particulars

ITEM	PARTICULARS
Service Units Type I (Air) Type II (Air/Oxygen) Operating Temperature Range	Military Specification MIL-S-52881 (ME) Military Specification MIL-S-52881 (ME) .250F to 1200F (-32° to 480C)
Mounting	Welded, Framed, Mechanically Fastened to M1 16A1 Trailer
Length (OA)	157 m (39876 mm)
Width (OA)	73 in. (1854 mm)
Height (OA)	66 m. (1676 mm)
Volume	405 cu. ft. (11.46 m3)
Shipping Weight (dry)	3280 lbs. (1478 Kg)
Highway Speed	55 mph
OFF Road Speed	15 mph
Cylinder, Compressed Gas, Air, ICC 3AA, 3500 psi (Type 1)	Military Specification RR-C-901
Cylinder, Compressed Gas, Oxygen, DOT 3AA, 2265 pst (Type II)	Military Specification RRC-901
Trailer, 3/4 Ton, M116A1 (Government Furnished)	MS 53028

Legend for Figure I

1. Housing Group (See Figure 7-1)
2. Compressed Gas Cylinders (Air or Oxygen)
3. Service Trough (Scuba Bottles)
4. Welded Fender Assy. (R.H.)
5. M116A1 3/4 Ton Trailer (Government Furnished)
6. Service Trough (Scuba Bottles)
7. Welded Frame
8. Stabilizing Jack
9. Side Cover

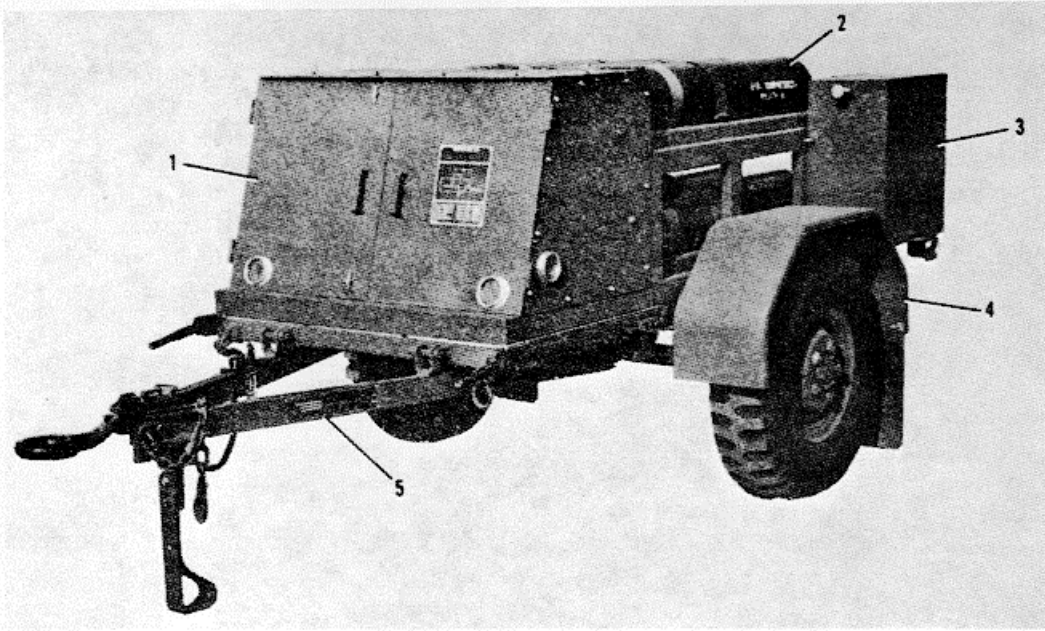

FRONT-RIGHT SIDE

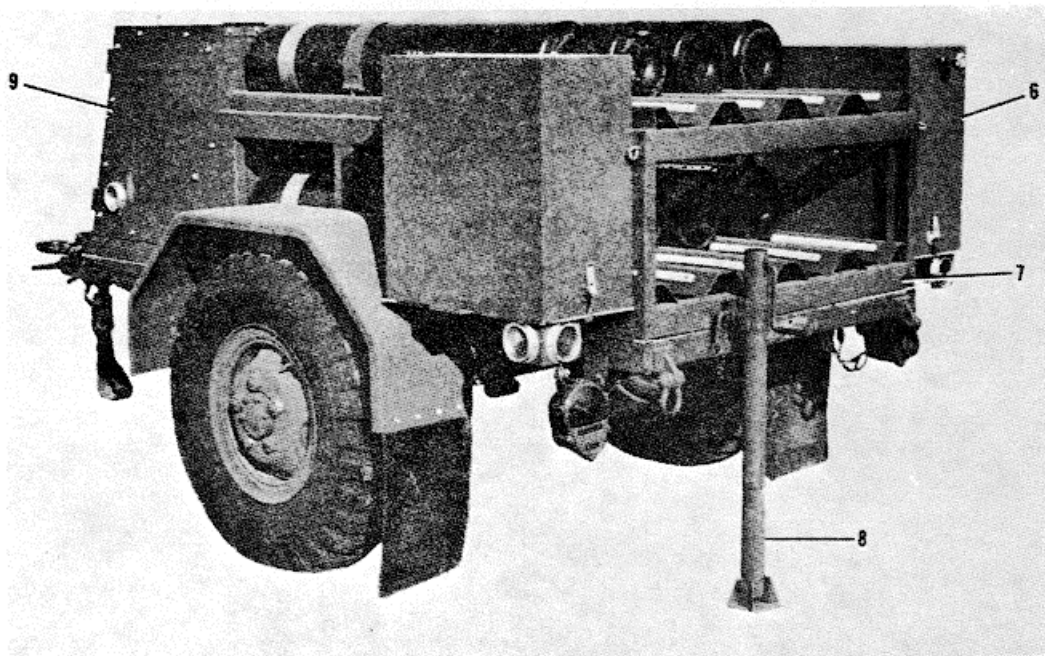

RIGHT SIDE-REAR

*Figure 1-1. Servicing Unit, Type I and Type II
1-3/(1-4 blank)*

SECTION II.

SPECIAL TOOLS AND TEST EQUIPMENT

2-1. GENERAL. No special tools are required for Inspection, repair and testing of the Type I (Air) or Type II (Air/Oxygen) Service Units.

2-2. SPECIAL TOOLS AND TEST EQUIPMENT
.Special tools for the M116A1 Chassis, Trailer, 3/4-Ton, 2-Wheel may be found in TM9-2330-202-14P.

2-1/(2-2 blank)

SECTION III.

PREPARATION FOR USE AND SHIPMENT

3-1. GENERAL. The Type I and Type II Service Units are 157 inches (39876 mm) long, 73 inches (1854 mm) wide, 66 inches (1676 mm) high and weighs 3280 lbs (1478 Kg) dry. The service units are shipped fully assembled, however there are certain steps which shall be taken prior to placing the service units into operation. This section contains step by step procedures to be followed when preparing the unit for use, storage, or shipment

3-2. PREPARATION FOR USE. To prepare the Service Units for use, proceed as follows

- a. Position and set rear stabilizing jack Remove any coating, blocking or protective material from service units.
- b. To deprocess the service units, refer to applicable DA Form 2258, Preservation and Depreservation guide for Vehicles and Equipment.

WARNING

Pay particular attention that there is no break

in the Oxygen Clean System of the Type II Service Unit

- c. Inspect service units for any damage to gauges, meters, valves, loose connections or mountings, loose missing hardware, frayed or missing wiring on the M I 16A I Chassis, or any other damage Check all air/oxygen tubing and flex hose for tight connections and for any damage that may have resulted from a chaffing condition If damaged tube or flex hose assembly exists, replace the damaged Items as required.
- d. Close all control valves on the control panel
- e. Perform procedures contained in PRIOR TO OPERATION (Section IV) and INSPECTION AND PREVENTIVE MAINTENANCE (Section V), refer to Table 5-1

3-3. PREPARATION FOR STORAGE OR SHIPMENT. Preparation for storage or shipment of the Servicing Unit shall be in accordance with MIL-D-52838 (ME)

3-1/(3-2 blank)

SECTION IV.

OPERATING INSTRUCTIONS

4-1. GENERAL. This section describes the operating procedure, and the operating controls of the Type I (Air) and Type II (Air/Oxygen) Servicing Units. The Type I Servicing Unit carries eight (8) 3,500 psi (24115 kPa) air supply cylinders. This Type I Servicing Unit is designed to service up to four scuba cylinders at one time. The Type II (Air/Oxygen) Servicing Unit carries four 3500 psi (24115 kPa) air supply cylinders and four 2260 psi (15, 571 kPa) oxygen supply cylinders. The Type II control panel provides the applicable dials, gauges, lever and manifolds to provide for two servicing outlets for both the air half and the oxygen half of the Type 11I Servicing Unit.

4-2. THEORY OF OPERATION. The servicing unit is connected to either the breathable air source (20 cfm, 3200 psi air compressor) or oxygen source by attaching a suitable service hose to the proper re-charge receptacle. The control panels are protected by a safety valve located in each manifold

4-3. CHARGING MODE (Breathable Air or Oxygen). A source of clean dry breathable air or breathable oxygen is attached to the recharging receptacle. The breathable air cylinders can be charged to a maximum of 3500 psi, while the oxygen cylinders can be charged to a maximum pressure of 2260 psi.

4-4. The breathable air or oxygen can be channeled from the compressed gas cylinders through the supply manifold to the air/oxygen purifiers by opening the manifold shut off valve. The air/oxygen supply then passes through the pressure regulator and servicing valve to the scuba manifold. The breathable air system and oxygen system are both protected by two safety valves, located at the supply manifolds and the scuba manifolds.

4-5. The air/oxygen supply passes from the scuba manifolds through the charging valves, flex hoses with attached yoke adapters to the scuba tank or receiving tanks. A method to mechanically bleed the breathable air or oxygen systems has been designed into each compressed gas system

4-6. OPERATING CONTROLS AND INDICATORS (See Figures 4-1 and 4-2) All controls and indicators necessary for operation of the Type I (Air) and Type II (Air/ Oxygen) Servicing Units are located on the control panel or behind the control panel. Identification and function of each control or indicator is as follows:

a. Type I (Air) Servicing Unit

- (1) Air Cylinder Pressure Gauge (1, Figure 4-1) These gauges are used to show the psig of the air cylinders.
- (2) Cam Lever Valve (2, Figure 4-1) Primary on-off valve controlling the pressure flow from the air cylinders.
- (3) Shut-off Valve - Scuba Manifold (3, Figure 4-) This valve is used to shut off the flow of air to the scuba manifold, from the air cylinders
- (4) Re-charge Valve (4, Figure 4-1) Control valve for recharging of breathable air cylinders Valve is maintained in the closed position except when air system is being recharged
- (5) Re-charge Connector (5, Figure 4-1) Servicing unit connection for the service hose from the breathable air source
- (6) Charging Valve (6, 7, Figure 4-1). Open/closed control valve that is used only when the breathable air scuba tanks are being charged
- (7) Air Pressure Regulator (8, Figure 4-1). The air pressure regulator is used to control the psig of breathable air that enters the scuba tanks through the scuba manifold
- (8) Service Pressure Gauge (9, Figure 4-1). Gauge that indicates psig available for use in charging scuba tanks.
- (9) Scuba manifold pressure gauge (10, Figure 4-1) This gauge indicates pressure build-up in the scuba tanks as they are being charged
- (10) Charging Valve (11, 12, Figure 4-1) Open/ closed control valve that is used only when the breathable air scuba tanks are being charged
- (11) Shut-off Valve, Supply Manifold (13, Figure 4-1). The supply manifold shut off valve is used to isolate the supply manifold from the purifier and scuba manifold.
- (12) Bleed Valve (14, Figure 4-1). The bleed valve is used when it is necessary to bleed off sections of the air supply system, or the total system

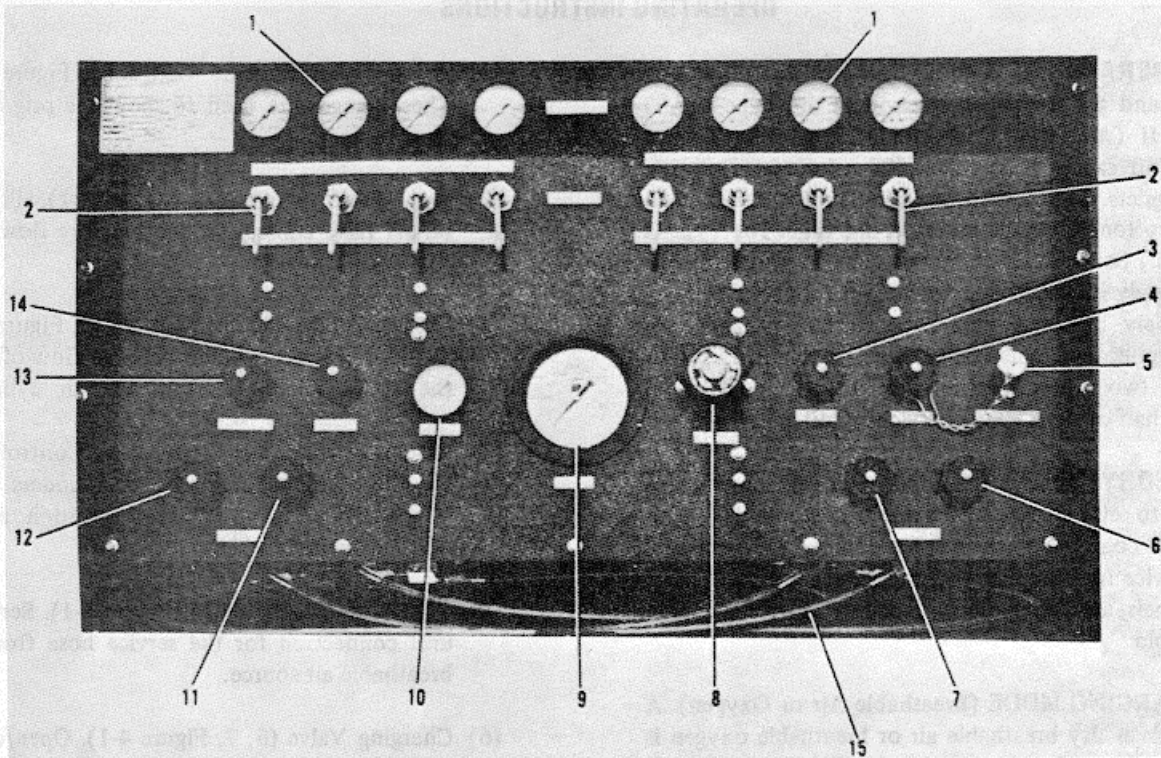

CONTROL PANEL, TYPE I (AIR)

1. AIR CYLINDER PRESSURE GAUGE
2. CAM LEVER VALVE
3. SHUT-OFF VALVE, SCUBA MANIFOLD
4. RE-CHARGE VALVE
5. RE-CHARGE CONNECTOR
6. CHARGING VALVE
7. CHARGING VALVE

8. REGULATOR, AIR PRESSURE
9. GAUGE, SERVICE PRESSURE
10. SCUBA MANIFOLD PRESSURE GAUGE
11. CHARGING VALVE
12. CHARGING VALVE
13. SHUT-OFF VALVE, SUPPLY MANIFOLD
14. BLEED VALVE
15. HOSE AND FILLER VALVE (AIR)

Figure 4-1. Operating Controls and Indicators (Type I) (Air)

- (13) Flex Hose and Filler Valve Adaptor (Air) (15, Figure 4-1) The hose assembly used to attach to scuba bottles for charging purposes
- b. Type II (Air/Oxygen) Servicing Unit (See Figure 4-2).
- (1) Air half of control panel
 - (a) Air Cylinder Pressure Gauge (1, Figure 4-2). These gauges are used to show the psig of the air cylinders.
 - (b) Cam Lever Valve (2, Figure 4-2). Primary on-off panel mounted valve controlling the pressure flow from the air cylinders to the supply manifold.
 - (c) Re-charge Connector (3, Figure 4-2). Servicing unit (panel mounted) connection for the breathable air servicing hose
 - (d) Re-charge Valve (4, Figure 4-2) Air system control valve for recharging air cylinders.
 - (e) Supply Manifold Shut-Off Valve (5, Figure 4-2). The supply manifold shut-off valve is used to isolate the supply manifold from the purifier and scuba manifold.
 - (f) Bleed Valve (6, Figure 4-2). The bleed valve is used when it is necessary to bleed off sections of the air supply system or the total system.
 - (g) Charge Valve, Scuba (7, 12, Figure 4-2). Open/closed control valve that is used only when the breathable air scuba tanks are being charged.
 - (h) Air Pressure Regulator (8, Figure 4-2) The air pressure regulator is used to control the psig of breathable air that enters the scuba tanks through the scuba manifold
 - (i) Service Pressure Gauge (9, Figure 4-2). Gauge that indicates psig available for use in charging scuba tanks
 - (j) Shut-off Valve to Scuba Manif (10, Figure 4-2) This valve is used to shut off the flow of air to the scuba manifold from the air cylinders
 - (k) Scuba Manifold Pressure Gauge (11, Figure 4-2) The gauge indicates pressure build-up in the scuba tanks as they are being charged
 - (2) Oxygen half of control panel.
 - (a) Oxygen Cylinder Pressure Gauge (13, Figure 4-2). These gauges are used to show the psig of the oxygen cylinders
 - (b) Cam-Lever Valve (14, Figure 4-2). Primary panel mounted ON-OFF valve controlling the pressure flow from the oxygen cylinders to the supply manifold.
 - (c) Re-charge Connector (15, Figure 4-2) Servicing unit (panel mounted) connection for the oxygen service hose
 - (d) Re-Charge Valve (16, Figure 4-2) Oxygen system control valve for recharging oxygen cylinders
 - (e) Supply Manifold Shut-off Valve (17, Figure 4-2) The supply manifold shut-off valve is used to isolate the supply manifold from the purifier and scuba manifold
 - (f) Bleed Valve (18, Figure 4-2) The bleed valve is used when it is necessary to bleed off sections of the oxygen system, or the total system
 - (g) Charge Valve, Scuba (19, 24, Figure 4-2) Open/closed control valve that is used only when the oxygen scuba tanks are being charged.
 - (h) Oxygen Pressure Regulator (20, Figure 4-2) The oxygen pressure regulator is used to control the psi of oxygen that enters the scuba tanks through the scuba manifold
 - (i) Service Pressure Gauge (21, Figure 4-2) Gauge that indicates psig available for use in charging scuba tanks.
 - (j) Shut-off Valve for Scuba Manifold (22, Figure 4-2). This valve is used to shut off the flow of oxygen to the scuba manifold from the oxygen cylinders
 - (k) Scuba Manifold Pressure Gauge (23, Figure 4-2). This gauge indicates pressure build-up

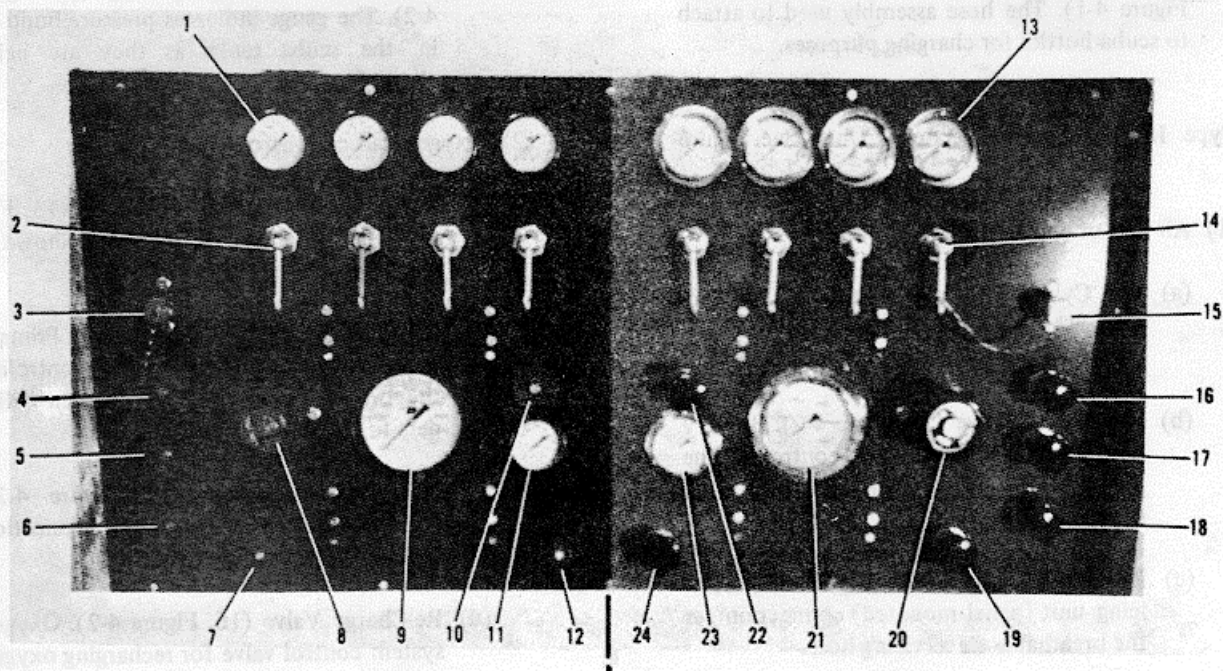

CONTROL PANEL, TYPE II (AIR/OXYGEN)

AIR

1. AIR CYLINDER PRESSURE GAUGE
2. CAM LEVER VALVE
3. RE-CHARGE CONNECTOR
4. RE-CHARGE VALVE
5. SUPPLY MANIFOLD SHUT-OFF VALVE
6. BLEED VALVE
7. CHARGE VALVE, SCUBA
8. AIR PRESSURE REGULATOR
9. SERVICE PRESSURE GAUGE
10. SERVICE VALVE
11. SCUBA MANIFOLD PRESSURE GAUGE
12. CHARGE VALVE, SCUBA

OXYGEN

13. OXYGEN CYLINDER PRESSURE GAUGE
14. CAM-LEVER VALVE
15. RE-CHARGE CONNECTOR
16. RE-CHARGE VALVE
17. SUPPLY MANIFOLD SHUT-OFF VALVE
18. BLEED VALVE
19. CHARGE VALVE, SCUBA
20. OXYGEN PRESSURE REGULATOR
21. SERVICE PRESSURE GAUGE
22. SERVICE VALVE
23. SCUBA MANIFOLD PRESSURE GAUGE
24. CHARGE VALVE, SCUBA

Figure 4-2. Operating Controls and Indicators (Type II) Air/Oxygen

in the scuba tanks as they are being charged.

4-7. OPERATION INSTRUCTIONS.

4-8. PRIOR TO OPERATION Prior to operating the service units, perform the following procedure.

a. Transport the unit to work site and select as level an area as possible to park the Service Units. Set hand brakes and stabilizing jack.

WARNING

High pressure gas is dangerous. Check all tubing and service hoses for damage, cracks or deterioration.

b. Perform all inspection, checks, and services required. Refer to Table 5-1.

WARNING

Under no circumstances should the air or oxygen purification cartridges in the purification cylinders (7, 8, Figure 7-1) be allowed to become contaminated with moisture. If in doubt, change the cartridges.

WARNING

Under no circumstances will cartridges be interchanged between the air or oxygen purified cylinders on a Type II system.

NOTE

When air or oxygen purification cartridges are changed, make certain to record the time the change was made. Approximate time lapse for cartridge change is 8 hours.

Actual frequency of cartridge change depends on governing weather conditions at a given time or place, and the condition of the compressed gas (air or oxygen) being used.

c. Check the number of hours that the cartridges in the purifying cylinders have been used. If the next period of operation will exceed the remaining useful life of the cartridges, replace the cartridges.

4-9. TYPE I (AIR) - CHARGING THE TYPE I (AIR) SERVICING UNIT (See Figure 4-3)

CAUTION

The stems and seats of the control panel valves may be damaged by overtightening. All valves should be tightened enough to prevent leakage.

a. Prior to attaching the service hose to the servicing unit, make sure all valves are closed, including drain valves.

b. Attach a source of clean, dry, breathable air to recharge connection (9) on control panel.

CAUTION

The stems and seats of the control panel valves may be damaged by overtightening. All valves should be tightened enough to prevent leakage.

c. Close manifold shut-off valves (10), open cylinder valves (2) on gas cylinders (1) to be charged and place cam lever valve (5) in the up position. Open recharge valve (8).

d. Service air cylinder (1) to a maximum 3200 psi for breathable air (Type I).

e. Close recharge valve (8).

WARNING

Do NOT disconnect service hose until service hose line has been bled of all pressure.

f. Open service hose bleed valve located on the source furnishing the breathable air.

g. Disconnect service hose.

h. Connect yoke adaptor (21) to scuba tanks.

i. Be sure scuba manifold bleed off valve (18) is closed.

j. Open manifold shut-off valve (10).

k. Adjust regulator (12) to desired pressure.

l. Open scuba manifold servicing valve (14) and scuba manifold charging valve (19).

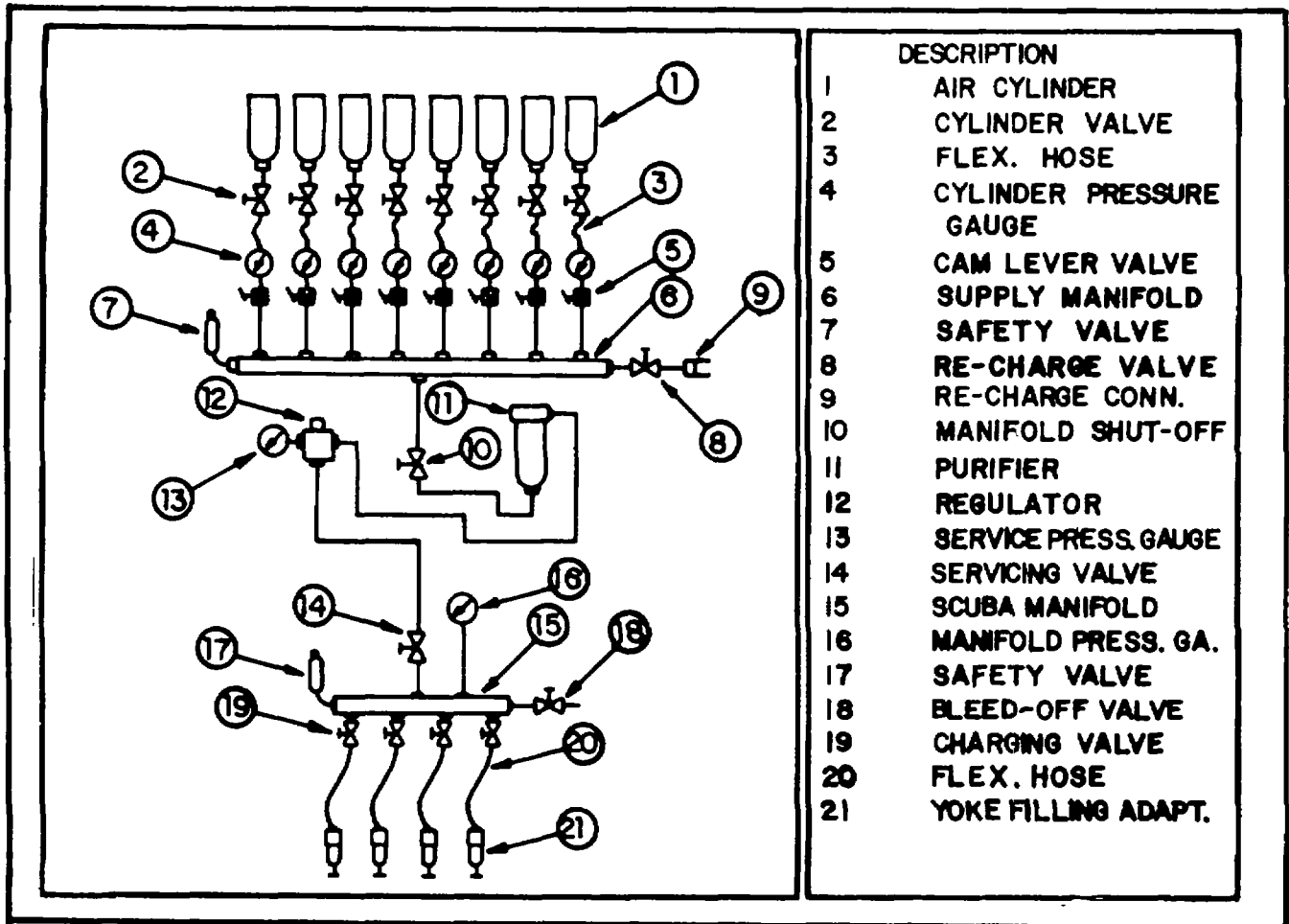

Figure 4-3. Component Layout, Type I (Air)

- m. Open valve on scuba tank
- n. Charge scuba tanks to desired pressure using the manifold pressure gauge (16) as an indicator
- o. Close scuba tank charging valve (19).
- p. Close valve on scuba tank.

WARNING

Do not disconnect yoke adaptor (21) from scuba tank until flex hose (20) has been bled of all pressure.

- q. Bleed flex hose (20) air pressure at yoke adaptor (21) bleed screw.
- r. Remove the yoke adaptor (21) from the scuba tank.

4-10. TYPE II (AIR/OXYGEN)- CHARGING THE TYPE II (AIR/OXYGEN) SERVICING UNIT (See Figure 4-4).

a. Prior to attaching the service hose to the Type II Servicing Unit, make sure all valves are closed, including drain valves.

b. AIR half of Type II control panel (Figure 44).

- (1) Attach a source of clean, dry, breathable air to the recharge connection (9)
- (2) Open cylinder valves (2) of air cylinders (1) to be charged and place cam lever valve (5) in the up position. Open recharge valve (8).
- (3) Service air cylinder (1) to a maximum 3200 psi for breathable air (Type I)
- (4) Close recharge valve (8).

WARNING

Do not disconnect service hose until service hose line has been bled of all air pressure.

- (5) Open service line drain valve, located on the source furnishing the breathable air.
- c. To charge scuba tanks (see Figure 4-4)
- (1) Connect yoke adaptor (21) to scuba tanks.
 - (2) Be sure scuba manifold bleed valve (18) is closed.
 - (3) Open manifold shut-off valve (10)
 - (4) Adjust regulator (12) to desired pressure.
 - (5) Open scuba manifold servicing valve (14) and scuba charging valve (19)
 - (6) Open valve on scuba tank, charge scuba tank to desired pressure using the manifold pressure gauge (16) as an indicator
 - (7) Close scuba tank charging valve (19)
 - (8) Close valve on scuba tank.

WARNING

Do NOT disconnect yoke adaptor (21) from scuba tank until flex hose (20) has been bled of all pressure

- (9) Bleed flex hose (20) pressure at yoke adaptor (21) bleed screw before removing the yoke adaptor (21) from the scuba tank
- d. OXYGEN half of Type II control panel (Figure 4-4).
- (1) Attach a source of breathable oxygen to the recharge connection (30) on the oxygen control panel
 - (2) Close manifold shut-off valve (31), open oxygen cylinders (22) to be charged and place cam lever valve (26) in the up position. Open recharge valve (29)

- (3) Service oxygen cylinders (22) to maximum 2265 psi for oxygen Type II gas cylinders
- (4) Close recharge valve (29)

WARNING

Do NOT disconnect oxygen service hose until the service hose line has been bled of all pressure.

- (5) Open service line drain valve located on the source furnishing the oxygen
- e. To charge scuba tanks (see Figure 4-4)
- (1) Connect yoke adaptor (42) to receiving tank
 - (2) Be sure scuba manifold bleed valve (39) is closed
 - (3) Open manifold shut-off valve (31)
 - (4) Adjust regulator (33) to desired setting
 - (5) Open scuba manifold service valve (35) and scuba charging valve (40)
 - (6) Open valve on receiving tank, charge receiving tank to desired pressure using the manifold pressure gauge (37) as an indicator
 - (7) Close scuba tank charging valve (40)
 - (8) Close valve on receiving tank

WARNING

Do NOT disconnect yoke adaptor (42) from receiving tank until flex hose (41) has been bled of all pressure

- (9) To bleed flex hose (41), close manifold service valve (35), open charging valve (40), open manifold bleed valve (39) Pressure gauge (37) should be watched to help determine when pressure has been removed from the flex hose (41).
- (10) Remove yoke adaptor (42) from receiving tank.

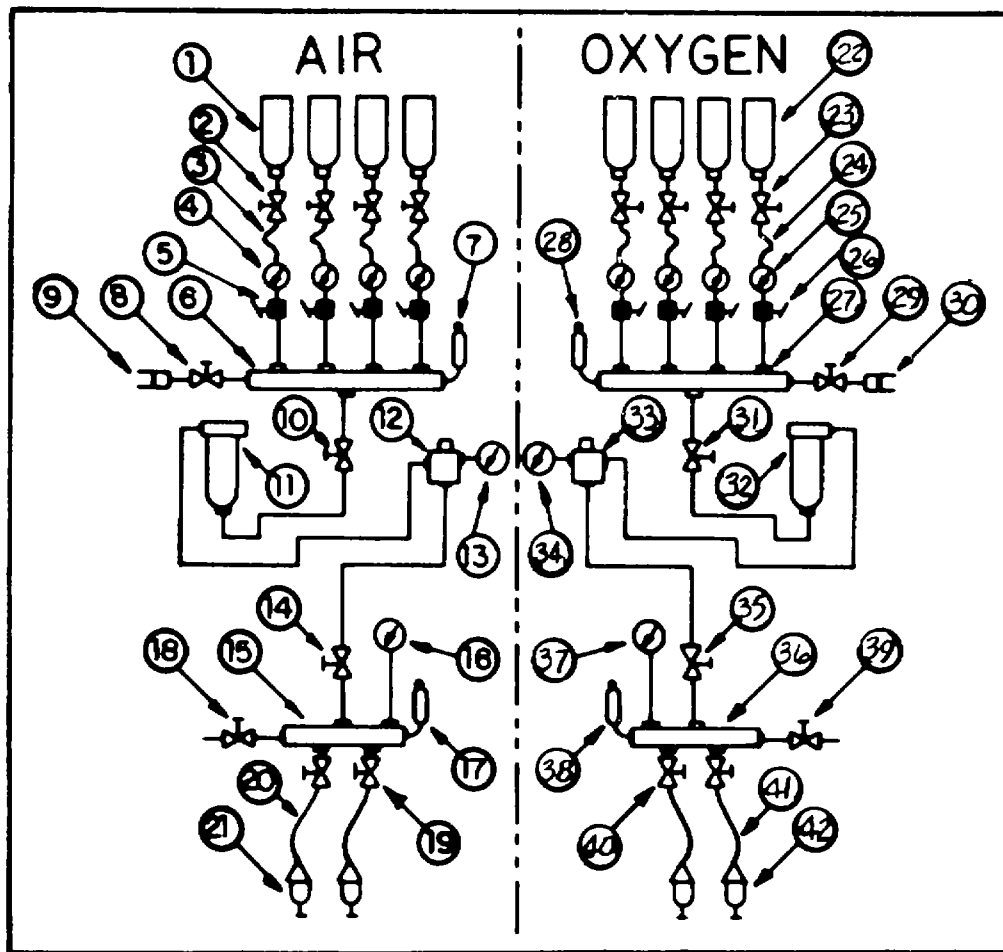

1. AIR CYLINDER
2. CYLINDER VALVE
3. FLEX. HOSE
4. CYLINDER PRESS GA
5. CAM LEVER VALVE
6. SUPPLY MANIFOLD
7. SAFETY VALVE
8. RE-CHARGE
9. RE-CHARGE CONN
10. MANIFOLD SHUT-OFF
11. PURIFIER
12. REGULATOR
13. SERVICE PRESSURE GAUGE
14. SERVICE VALVE
15. SCUBA MANIFOLD
16. MANIFOLD PRESS. GA
17. SAFETY VALVE
18. BLEED-OFF VALVE
19. CHARGING VALVE
20. FLEX. HOSE
21. YOKE FILLING ADAPT

22. OXYGEN CYLINDER
23. CYLINDER VALVE
24. FLEX. HOSE
25. CYLINDER PRESS. GA
26. CAM LEVER VALVE
27. SUPPLY MANIFOLD
28. SAFETY VALVE
29. RE-CHARGE VALVE
30. RE-CHARGE CONN.
31. MANIFOLD SHUT-OFF
32. PURIFIER
33. REGULATOR
34. SERVICE PRESSURE GAUGE
35. SERVICE VALVE
36. SCUBA MANIFOLD
37. MANIFOLD PRESS GA.
38. SAFETY VALVE
39. BLEED-OFF VALVE
40. CHARGING VALVE
41. FLEX HOSE
42. YOKE FILLING ADAPT

Figure 4-4. Component Layout, Type II (Air/Oxygen)

4-11. TO BLEED PRESSURE FROM TYPE I AND TYPE II SERVICING UNITS

a. Type I Servicing Unit - to bleed the air pressure from a Type I servicing unit, proceed as follows (See Figure 4-3)

- (1) Close charging valves (19) and close air cylinder valves (2)
- (2) Place cam lever valves (5) in the up (open) position
- (3) Open manifold shut-off valve (10) and service valve (14).
- (4) Open bleed-off valve (18)

NOTE

If it is necessary to bleed-off the breathable air remaining in the air cylinder (1), open air cylinder valves (2).

- (5) When all pressure has bled from the breathable air system, close all open valves

b. TYPE II SERVICING UNIT (AIR/OXYGEN)
- To bleed the Air/Oxygen pressure from a Type II Servicing Unit, proceed as follows (see Figure 4-4)

- (1) AIR half of Type II System - bleed AIR pressure as per paragraph 4-11 a
- (2) Oxygen half of Type II system is as follows
 - (a) Close charging valves (40) and close oxygen cylinder valves (23)
 - (b) Place cam lever valves (26) in the up (open) position
 - (c) Open manifold shut-off valve (31) and service valve (35)



Open BLEED-OFF VALVE slowly Bleed system slowly.

- (d) Open bleed-off valve (39)

NOTE

If It Is necessary to bleed-off the breathable oxygen remaining in the oxygen cylinders (22), open oxygen cylinder valves (23), lever cam valve (26) and bleed valve (39)

- (e) When all pressure has bled from the oxygen system, close all open valves

4-11. GAS CYLINDER LOCATION ON TYPE I (AIR) AND TYPE II (AIR/OXYGEN) SERVICING UNITS

NOTE

All component part descriptions as to location is from the Panel View

a. For the purposes of attaching flex hose assemblies from the gas cylinders (Air or Air/Oxygen) to the proper cam lever valve on the control panels, the following number sequences shall apply (see Figure 4-5)

TYPE I (AIR)

- (1) Facing the control panel, from left to right, cam lever valves will be numbered 1 through 8 Attach flex hose line from numbered gas cylinder to the correspondingly numbered cam lever valve

TYPE II (AIR/OXYGEN)

- (2) AIR - See Type I above
- (3) OXYGEN - Facing the control panel oxygen bulkhead is on the right hand side, numbered one (1) through four (4) Attach flex hose line from numbered oxygen gas cylinders to correspondingly numbered cam lever valve

4-12 EMERGENCY BLEED PROCEDURE In case of an emergency that would require immediate bleeding of the breathable air servicing unit (Type I) or air/oxygen servicing unit (Type II), open all cam lever valves (2, Figure 4-1) and (2, 14, Figure 4-2) and open bleed valves (14, Figure 4-1) and 6, 18, Figure 4-2)

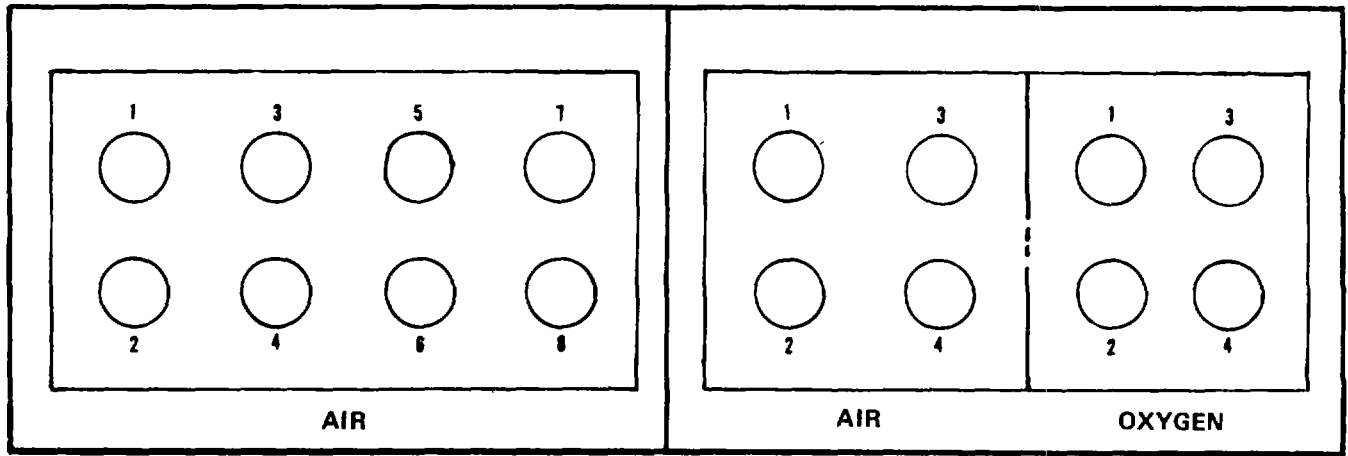

TYPE I (Air)

TYPE II (Air/Oxygen)

Figure 4-5. Cylinder Locations, Bulkhead (Panel View)

SECTION V.

MAINTENANCE INSTRUCTIONS

5-1. GENERAL. This section contains inspection and preventative maintenance instructions for the Type I (Air) and Type II (Air/Oxygen) Servicing Units.

(1) Using a strap wrench or equivalent, unscrew cylinder caps from either the air or oxygen purifier cylinder.

5-2. INSPECTION AND PREVENTATIVE MAINTENANCE.

a. AIR PURIFICATION CYLINDERS (See Figure 5-1 and Figures 7-2, 7-3). The cartridges shall be changed in accordance with the number of recorded operating hours (see Table 5-1). To change the cartridges on cylinders, proceed as follows.

WARNING

Do NOT interchange cartridges between air and oxygen purifier cylinders on Type 11 Servicing Units Do NOT reuse filter cartridges

WARNING

Make certain that all air pressure has been bled from the air or oxygen purifier before purifier cap is unscrewed

WARNING

Use oxygen clean procedures. Take every precaution when removing Type II oxygen purifier cartridge that no foreign substance is allowed to enter into oxygen purifier cylinder. If in doubt oxygen clean cylinder before using.

Table 5-1. Inspection, Checks, and Services

COMPONENT OR PART	INSPECTION, CHECK, OR SERVICE	OPERATIONAL TIME PERIOD
Entire Servicing Unit	Visually inspect for loose or missing hardware	Before each use.
Air and Oxygen Flex Hose and Tubing	Inspect entire air or oxygen system for leaks, cracked fittings and for chaffing conditions on flex hose and tubing	Before each use Before and after shipment, storage or servicing unit has been moved
Air or Oxygen (MA-2) Purification Cartridge	Replace cartridge as necessary Refer to Prior To Operation (Section IV, para 4-8.b.)	8 hours, or as operational conditions dictate.
Gauges	Visually inspect for proper working order	Before each use and during use
Gas Cylinder Clamping Band	Visually and physically check each clamping band to determine that band is firmly securing gas cylinder to channel frame	Before each use Before each movement of the service units
Service Unit Welded Frame	Visually check welded frame for cracks or broken welds Repair as necessary.	6 months.
Stabilizing Jack	Visually check jack for damage and working order Check pin for damage.	Before each use.
M1 16Al Trailer	As per TM 9-2330-202-14P	

- (2) Remove cartridge from cylinder.
 - (a) Type I and Type II (Air) Purifier Cylinder Thoroughly clean the inside of cylinder with a-lint free cloth using hot water and detergent solution per Federal Specification P-D-220 Allow to air dry.
 - (b) Type II (Oxygen) Purifier Cylinder. Closely inspect inside of oxygen purifier cylinder Make certain no foreign substance is present Oxygen clean as necessary
- (3) Examine o-rings in the cylinder caps and replace if damaged (See Figure 7-2 and 7-3)
- (4) Place fresh type MA-2 Cartridges In the Type I and Type II Air Purifier Cylinder, and in the Type II Oxygen Purifier Cylinder

CAUTION

Screw the cap assembly snugly in place Do NOT over tighten

- (5) Using a strap wrench, screw cylinder caps back onto the cylinders Apply enough force to caps to pierce the cartridges with the built-in piercing blades have entered cartridges Screw cap down firmly against cylinder Do not overtighten

NOTE

Each time cartridges are Installed, record time and date on applicable forms

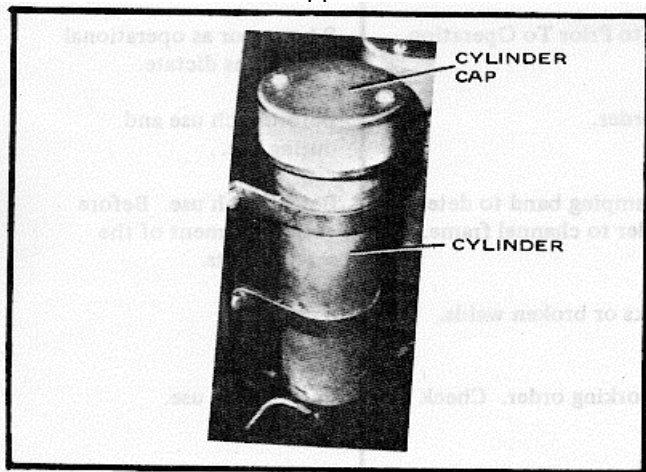

Figure 5-1. Purification Cylinder

b. WELDED FRAME ASSEMBLY (See 19, Figure 7-1) If it is necessary to repair a cracked weld on the frame proceed as follows

WARNING

Do NOT use welding equipment near compressed gas cylinders or compressed gas systems

WARNING

Make sure all air or oxygen pressure has been removed from the tubing and flex hose system before any disassembly of the Service Units take place

- (1) Remove all air or oxygen pressure from Service Unit System (see Section IV) before disassembly begins
- (2) Remove compressed gas cylinders from Service Units. (See Section VI, Repair Instructions)
- (3) As required, remove control panel from Service Units. (See Section VI, Repair Instructions)

5-3. CHASSIS: Trailer, 3/4-Ton, 2-Wheel, M116AI - See TM 9-2330-202-14P for Inspection and preservative maintenance and lubrication instructions

5-4. TROUBLESHOOTING (See Table 5-2) This table will aid and guide maintenance personnel by indicating some of the potential problem areas while operating the service units.

Table 5-2. Troubleshooting

TROUBLE	PROBABLE CAUSE	REMEDY
<p>1 Pressure loss in system</p> <p>4. Slightly open valve</p>	<p>1. Leaking flex hose on tube</p> <p>2. Loose connection</p> <p>3. Valve leaking</p> <p>4. Check charging valves</p>	<p>1. Check all flex hoses and tubing</p> <p>2. Check all connections for tightness</p> <p>3 Determine leaking valve and replace</p>
<p>2. No output air or oxygen at yoke filing adaptor</p>	<p>1. Valve closed lever valve, manifold shut-off valve,</p> <p>2. Empty gas cylinder</p> <p>3. Non-operative valve</p>	<p>1. Determine if gas cylinder valve, cam-servicing valve and charging valve are open Check to see if regulator is set properly</p> <p>2. Check gas cylinder pressure gauge Fill gas cylinder</p> <p>3. Remove and replace valve</p> <p>4. Remove and replace</p>
<p>3. Faulty Pressure Regulator</p>	<p>1. Will not hold psi setting</p>	<p>1. Remove and replace pressure regulator.</p>
<p>4. Faulty Pressure gauge reading</p>	<p>1. Low air oxygen pressure</p> <p>2. Faulty gauge</p>	<p>1. Charge air or oxygen gas cylinders</p> <p>2. Replace gauge</p>
<p>5. Faulty Gas Cylinder Valve</p>	<p>1. Failure of valve component</p>	<p>1. Remove and replace gas cylinder and gas cylinder valve</p>
<p>6. Contaminated air or oxygen</p>	<p>1. Contaminated air or oxygen purifier</p> <p>2. Contaminated source breathable air source or oxygen source</p> <p>3. Contaminated service unit system</p>	<p>1 Remove and replace M-2 cartridge (see Section IV)</p> <p>2. Have source inspected for contaminated cartridges and purification systems</p> <p>3. Purge and reclean breathable air systems (Type I) or Air/Oxygen Systems (Type 11) as required</p>
<p>7. M116A1 Trailer problems</p>		<p>1. Corrective action shall be taken as per TM 9-2330-202-14P</p>

SECTION VI.

REPAIR SECTION

6-1. REPAIR. The following paragraphs contain maintenance instructions for the Type I (Air) and Type II (Air/Oxygen) Servicing Units. These instructions will enable maintenance personnel to repair or replace defective parts, allowing the servicing unit to meet new equipment standards of operation. Instructions are included for the disassembly, cleaning, inspection, repair or replacement, assembly of detailed parts into subassemblies, subassemblies into assemblies, and final assembly of assemblies to form a complete servicing unit.

NOTE

After performing any repair upon the air compressor unit, refer to TEST (Section V) and test service units to ensure proper operation.

6-2. PRELIMINARY PROCEDURES In general, it is not necessary to completely disassemble the servicing units as illustrated in Figure 7-1. Operational checkout and troubleshooting will indicate the required degree of disassembly necessary and assemblies which require repair or replacement. Prior to complete disassembly of the servicing unit, the following step-by-step procedures shall be completed as follows.

a. On work station, set servicing unit hand brakes and position, set and pin stabilizing jack.

WARNING

Never attempt to disassemble any part of the service units without first having relieved all air or oxygen pressure from the system.

b. Open gas cylinder valves, cam-lever valves, shut-off valves and bleed valve.

6-3. SERVICING UNIT, TYPE I (AIR) AND TYPE II (AIR/OXYGEN). The following paragraphs contain disassembly, cleaning, inspection, repair or replacement, and assembly instructions for the air compressor unit. General shop practice standards for maintenance and overhaul shall be followed on all assemblies. General cleaning, inspection, and repair or replacement is as follows:

WARNING

Provide adequate ventilation when using cleaning solvent (Federal Specification P-D-680, Type II). Avoid prolonged breathing of vapors and minimize skin contact.

CAUTION

Solvents conforming to Federal Specification P-D-680, Type II shall not be used to clean any parts of the trap mounting group other than those specified herein. These solvents may cause damage to paint coatings, plastics, and rubber. Disposal of solvents conforming to Federal Specification P-D-680, Type II shall be accomplished in accordance with local state water pollution control laws. Consult local bioenvironmental engineer for guidance. In no instance should these solvents be allowed to contaminate streams or lakes. They may be disposed of by evaporation or burning under supervision.

NOTE

Do not allow parts to remain in cleaning solvent for extended periods of time or rust spots may form. If parts are not to be inspected immediately after cleaning, dip them in engine oil per Military Specification MIL-L-2104C or equivalent. Do not immerse electrical parts in cleaning solvent.

a. Cleaning

- (1) Clean all unpainted metal parts using cleaning solvent that is in accordance with Federal Specification P-D-680, Type II1, or equivalent. Wipe nonmetallic parts with a clean, lint-free cloth moistened in detergent and water and air dry.
- (2) Clean all painted surfaces by spraying with hot water and detergent solution per Federal Specification P-D-220. Parts that will be repainted may be cleaned with steam. After cleaning, refinish affected painted areas where required.

CAUTION

Do not use steam or water to clean any electrical components or assemblies such as electrical gauges, switches and solenoids

- (3) Clean electrical components with trichloroethane, per Federal Specification O-T-620 or equivalent.

WARNING

Proper precautions must be exercised to protect personnel. Stand clear of all tubing openings. After cleaning, drain tubes, and dry with low pressure compressed air (30 psig maximum [206 kPa]).

- (4) Clean outside and inside surfaces of the steel tubing and hose assemblies with compressed air, pressurized hot water and detergent or steam

b. Inspection. In general, inspect as follows

- (1) Inspect for visible wear, damage, distortion, cracks, breaks, and corrosion. Replace all o-rings, gaskets and seals.
- (2) Inspect threaded parts and hardware for stripped threads, cross-threading and for nicks and burrs.
- (3) Inspect flex hoses and tubing for evidence of leaks, cracks, pinching, chaffing conditions, damaged connecting nuts, and similar defects
- (4) Inspect painted surfaces for chipping, peeling or discolored paint.

c. Repair or Replacement. For the most part, repair of this equipment will be made by replacement of worn or damaged parts. Detailed repair and replacement procedures for specific parts are found in the following subassembly paragraphs.

- (1) Minor nicks, scoring or scratches on non-critical surfaces may be smoothed with crocus cloth per Federal Specification PC-458
- (2) Repair or replace damaged or defective steel tubing. To repair or replace steel tube assemblies attachment fittings, proceed as follows:

NOTE

Before attempting to repair tube fittings, make certain stainless steel tubing is of sufficient length to fit after cutting off end containing damaged fittings. If not long enough, replace while tube assembly.

(a) Cut off tubing just beyond damaged fitting

(b) Slide tubing nut and then the sleeve onto the tubing, refer to Figure 6-1. Make certain end of tubing is free of any burrs and is reasonably square.

(c) Insert the end of the tubing into mating fitting, see Figure 6-2. Make certain that tubing end is bottomed on fitting shoulder. Apply a good grade of lubricant on end of tubing.

(d) Turn tubing nut slowly with wrench while turning tubing with other hand. When the sleeve grips the tubing, that is when the tubing can no longer be turned by hand, stop turning nut and note position of wrench. This is termed the nng grip point

(e) Then, tighten the nut an additional one turn past the ring gnp point.

(f) Unscrew nut and remove the tubing from the mating fitting, or presetting tool. Inspect the preset as described in Figure 6-1.

(g) When installing a preset tubing assembly, lubricate the threads and seat of the fitting and the shoulder of the sleeve with a small amount of good grade lubricant such as clean compressor oil.

CAUTION

At installation of tubing assemblies, do not overtighten tubing nuts.

(h) Insert tubing assembly into fitting and tighten nut until a sharp rise in torque is felt. Starting at position of sharp torque rise, tighten the nut 1/4 additional turn to complete the assembly.

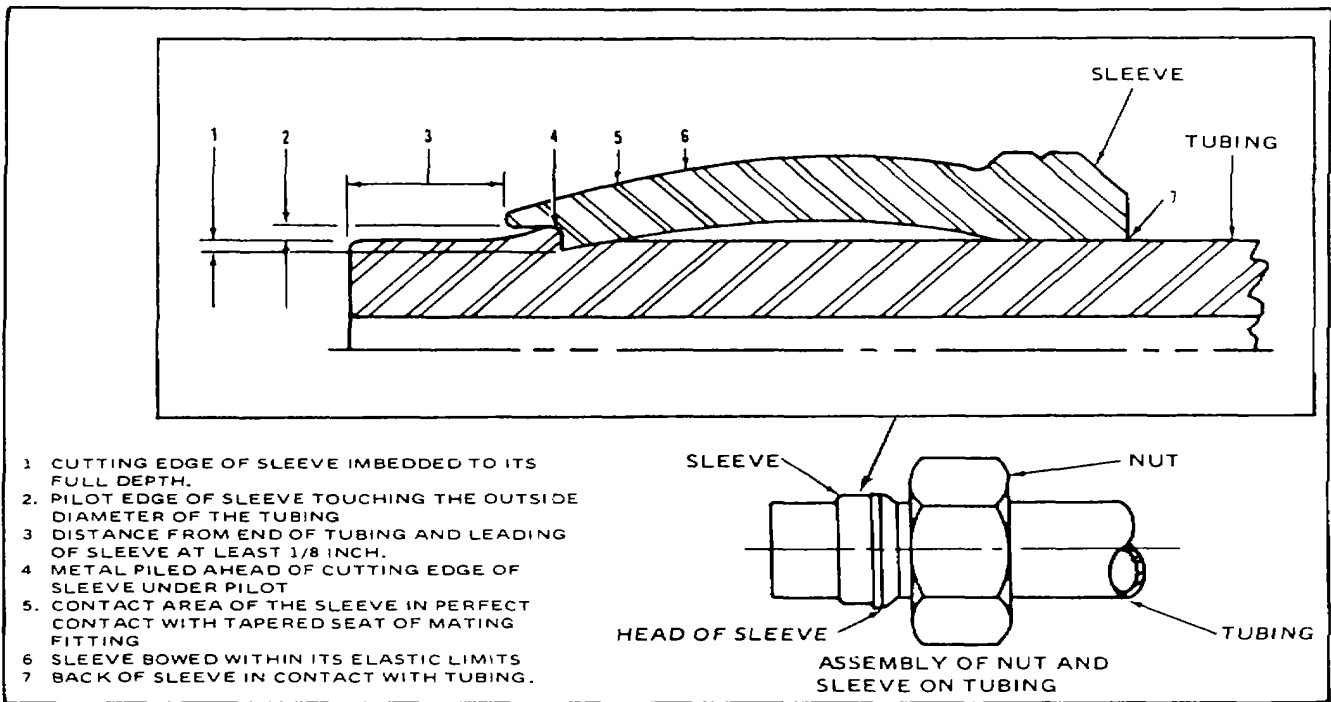

Figure 6-1. Steel Tubing and Fitting Assembly

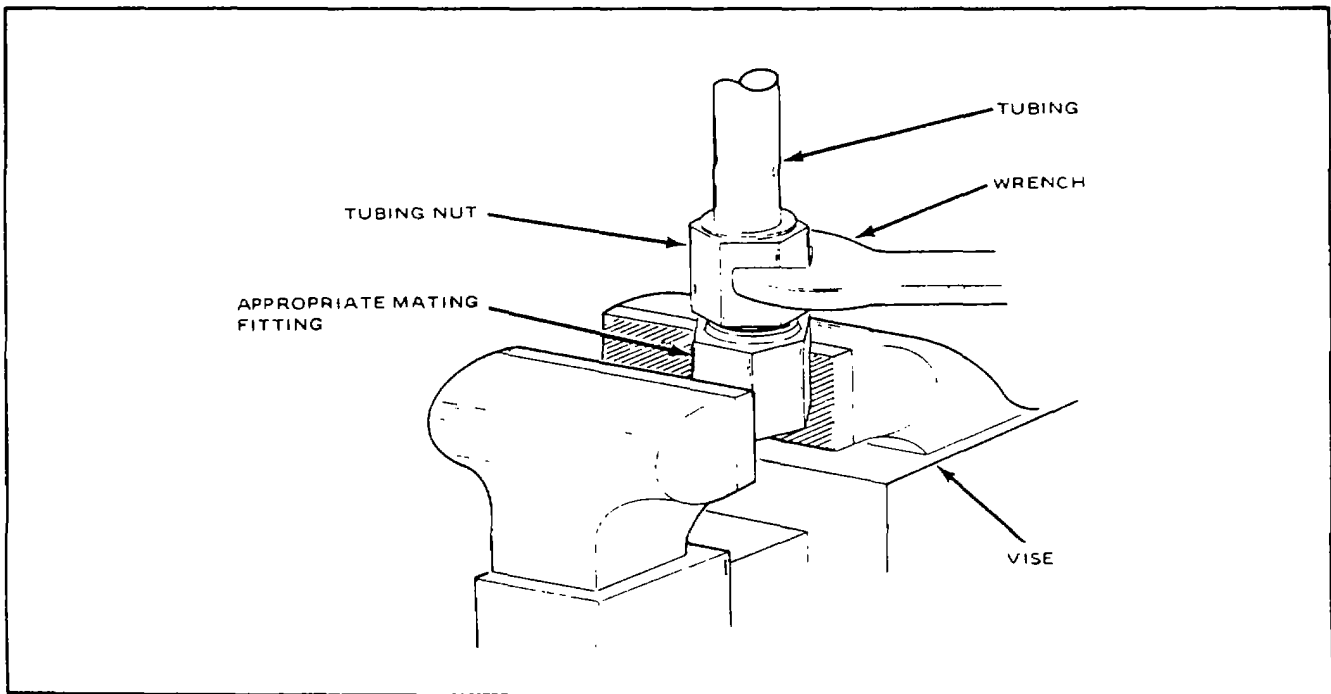

Figure 6-2. Presetting Tubing Sleeve

NOTE

At the point where the torque starts to rise, the sleeve and tubing are just touching the seat. An additional 1/4 turn produces a seal with the fitting and restores the bow to the sleeve.

- (3) Replace damaged or defective fittings.

6-4. DISASSEMBLY OF MAJOR COMPONENTS.

Limit disassembly of major components to the extent necessary to repair or replace a given assembly. All major components are covered in the following paragraphs. Refer to Figure 7-1 for major components.

NOTE

Unless otherwise specified, all figures referenced in this section will be found in Section VII, Illustrated Parts Breakdown.

NOTE

Remove tubing and hose assembly as needed (see Figure 6-1) in the disassembly process. Tag tube or hose assembly for reassembly purposes.

6-5. PREPARATION FOR DISASSEMBLY OF SERVICING UNITS

Position servicing unit at the maintenance site, set hand brakes and position and set stabilizing jack (17, Figure 7-1).

- a. Disassembly Disassemble the servicing unit only to the extent necessary to repair or replace a defective part or parts.

WARNING

Do not attempt to disassemble any part of the air pressure system without first being sure that all pressure has been relieved from the system.

- (1) Close gas cylinder (10, 11) valves, open cam lever valves (2, Figure 4-1), shut off valve (3), shut off valve (13) and open bleed valve (14).

WARNING

If gas cylinders contain pressurized gas when removed, attach applicable warning tags.

- (2) Unscrew and remove flex hose assembly from the gas cylinder valve (10, Figure 7-1).

WARNING

If filled pressurized gas cylinders are removed and are to be stored, store in a non-hazardous area, chained securely, or equivalent, so they cannot fall or be damaged.

- (3) Loosen tension on clamping band (9) by unscrewing band handle and carefully remove gas cylinders (10). Store cylinders in a safe, clean location.
- (4) Remove screws, washers, and nuts from hinged top cover (11, Figure 7-1), and remove cover. Remove screws and nuts from side panels (2) and remove panels. Remove screws, washers and nuts from left door panel (3) and right door panel (4). Unless it is necessary to replace a faulty door latch, do not remove the latches.
- (5) Unscrew and disengage tube assemblies (1, 2, Figure 7-2) from the back of the control panel (13, Figure 7-1).
- (6) Unscrew and remove screws and nuts attaching the control panel (13) to the welded frame assembly (19). Position control panel in a jig or stand suitable constructed to hold control panel during disassembly procedure.

NOTE

Note positioning of elbows in purification cylinder before cylinder is removed.

- (7) Unscrew and remove nuts, washers and screws attaching the tool box (6) and undershield (5) to the welded frame assembly (19).
- (8) Remove tubes (1, 2, Figure 7-2), tag for reassembly purposes. Remove nuts, screws, lock-washers, and brackets, (5, 6, Figure 7-2) from air purification cylinder (7, Figure 7-1) (See Figure 7-2 for breakdown). Remove air purification cylinder group from the welded frame assembly (19).
- (9) Unsnap and remove service through (18) from through support. Do not disassemble service.

trough (18) If it is not necessary Unscrew and remove nut, washers and screws holding the trough support to the welded frame assembly (19).

- (10) Unscrew and remove nuts, washers and screws securing the fender assemblies (15) to the welded frame assembly (19) Do not remove the splash guards (16) from the fender assemblies (15) unless it is necessary.
- (11) Remove the roll pin on the inside of the frame assembly and remove stabilizing jack (17).



Use a lifting device of the proper size to remove the welded frame assembly from the M116A1 trailer chassis.

- (12) Unscrew and remove the nuts, washers and screws attaching the welded frame assembly (19) to the M116A1 trailer chassis. Using a suitable lifting device (1/2 ton), lift welded frame assembly from the M116A1 Trailer Chassis and position on suitable work stands
- (13) Remove webbing (20) from M116A1 Trailer and from the service trough support (18) only as required for replacement purposes

b. Cleaning Refer to paragraph 6-3 a. for general cleaning instructions.

c. Inspection Refer to paragraph 6-3.b. for general inspection requirements.

- (1) Check all fittings, tubing, and flex hose for cracks, chaffing or damage.
- (2) Insure that the purifier cylinder is clean and that no odor or residue remains from the cleaning process

d. Repair or Replacement. Refer to paragraph 6-3.c. for general repair or replacement instructions.

- (1) Replace all damaged fittings, tube or flex hose assemblies.
- (2) Repair or replace sheet metal components as required.

e. Assembly To assemble the servicing unit, proceed as follows (see Figure 7-1)

- (1) If fabric (20) was removed from M116A1 Trailer, or from the service trough support (18), install webbing (20) as required.
- (2) Using a suitable lifting device, lift the welded frame assembly (19) and position the M116A1 trailer under the frame and lower the frame into the trailer. Fasten the frame assembly (19) to the M116A1 Trailer using screws, washers and nuts
- (3) Insert the stabilizing jack (17) into its frame recess and secure by inserting roll pin. Position and set jack (17).
- (4) Using screws, washers and nuts, position and secure fender assemblies (15) to the welded frame assembly (19).
- (5) Using screws, washers and nuts, position and secure service trough base (18) to the welded frame assembly (19) Position service troughs (18) in place and attach trough to its base.
- (6) Using screws, washers and nuts, attach under shield (5) to welded frame assembly (19) Using attaching screws, washers and nuts, attach the tool box (6) to the welded frame assembly (19).
- (7) Using screws, washers and nuts, loosely assemble brackets (5, 6, Figure 7-2) to welded frame assembly (19, Figure 7-1). Slide purification cylinder (23, Figure 7-2) into brackets (5, 6), position cylinder and tighten attaching screws and nuts. Install tubes (1, 2, Figure 7-2) on cylinder (23).
- (8) Using screws and nuts, position and attach control panel (13) to the welded frame assembly (19). Attach tubes (1,2, Figure 7-2) to the rear of the control panel (13). (See Figure 7-4, Sheet 2 of 2 for tube attaching points).
- (9) Using applicable screws, washers and nuts, position the right hand door (4) and left hand door (3) and attached to the welded frame assembly (19). Using screws and nuts, attach the side panels to the welded frame assembly. Using nuts, washers and screws attach the hinged top cover (1) to the welded frame assembly (19)

- (10) Position the air cylinders (10) on frame rails and push cylinders (10) as far forward as they will go against the steel bulkhead. Secure air cylinders in place by thoroughly tightening the clamping band holding the air cylinders (10) to the frame (19) rails.
- (11) Attach flux hose assembly to the gas cylinder valve (10).

- (8) Loosen and remove cam lever valve (2) hold down nut. Remove valve from the rear of the panel.
- (9) Remove screws (3) and washers (4). Remove the supply manifold and scuba manifold (18, 26, Figure 7-4, Sheet 2 of 2) and manifold mounts (25) from the rear of the panel.

6-6. CONTROL PANEL ASSEMBLY, TYPE I (AIR)

(See Figure 7-4.) The following paragraphs contain disassembly, cleaning, inspection, repair or replacement and assembly instructions for the Type I control panel assembly.

a. Disassembly. Disassemble the control panel assembly only to the extent necessary to repair or replace a defective part or parts.

NOTE

Tag tube assemblies for re-assembly purposes

- (1) Disconnect and remove cam lever valve to pressure gauge tube assemblies (1, Figure 7-4, Sheet 2 of 2).
- (2) Disconnect and remove cam lever valve to supply manifold tube assembly (2).
- (3) Disconnect and remove recharge valve to supply manifold tube assembly (3), and supply manifold to supply manifold shut-off valve tube assembly (3).
- (4) Disconnect and remove pressure regulator to scuba manifold shut-off valve tube assembly (5). Disconnect and remove scuba manifold shut-off valve to scuba manifold tube assembly (6).
- (5) Disconnect and remove service pressure gauge to pressure regulator tube assembly (7). Disconnect and remove scuba manifold to manifold pressure gauge tube assembly (8).
- (6) Disconnect and remove scuba manifold to bleed valve tube assembly (6). Disconnect and remove scuba manifold to charging valve tube assemblies (9).
- (7) Loosen and remove gas cylinder pressure gauge (1, Figure 7-4, Sheet 1 of 2) mounting nuts and clamps. Remove gauge (1) from panel.

NOTE

Tag valves for re-assembly purposes

- (10) Remove the nuts from the face of the supply manifold shut-off valve (5, Figure 7-4, Sheet 1 of 2), bleed valve (5), scuba manifold shut-off valve (5), recharge valve (5) and scuba charge valves (5). Remove the handles and valve hold down nuts. Remove valves from the rear of the panel.
- (11) Remove nuts and clamp from scuba manifold pressure gauge (1). Loosen and remove nuts and clamp from the service pressure gauges (6). Remove gauges from the panel.
- (12) Remove pop-off cap from middle of air pressure regulator (8) handle, remove nut and handle, remove screws (7) from regulator (8) and remove from rear of the panel.
- (13) Unscrew and remove cover (9), screws and nuts securing air panel mount (21, Figure 7-4, Sheet 2 of 2) to the panel. Remove panel mount (21), do not remove adapter (10, Figure 7-4, Sheet 1 of 2) from panel mount unless necessary.



Care shall be taken to insure that no cleaning agent deposits are left on/in components after the cleaning process.

b. Cleaning. Refer to paragraph 6-3 a for general cleaning requirements.

- (1) Wash glass gauge faces with a soft cloth and warm soapy water, or equivalent. Dry with a clean lint-free cloth. Use care not to damage gauges.

CAUTION

Proper precautions must be exercised to protect personnel. Stand clear of all tubing openings. After cleaning, drain tubes and dry with low pressure compressed air (30 psig, 207 kPa maximum).

- (2) Clean inside and outside surfaces of tubing and flex hose assemblies with compressed air, pressurized hot water and detergent or steam.
- c. Inspection. Refer to paragraph 6-3-b for general inspection procedures.
 - (1) Damaged gauges.
 - (2) Damaged cam lever and hand valves.
 - (3) Test safety valves. Connect valve to be tested to a gauge and regulated 4,000 psig (27,580 kPa) air or nitrogen source (see Figure 6-3).

WARNING

Keep unprotected parts of body away from valve opening during test.

NOTE

Hydrostatic tester may be used in lieu of nitrogen or air pressure source.

- (a) Starting with zero pressure. Increase pressure to valve operating pressure.
- (b) If safety valve relieves pressure prior to, or after specified pressure and cannot be reset, safety valve is defective.
- d. Repair or Replacement. Refer to paragraph 6-3.c. for general repair or replacement procedures.
 - (1) Replace damaged or defective nipples, couplings and gauges.
 - (2) Replace all threaded parts having worn, stripped, or damaged threads.
 - (3) Replace damaged or defective tubing.
 - (4) Replace damaged or defective fittings.
 - (5) Replace identification plates. If damaged, or if markings are illegible.
 - (6) Straighten bent or dented panel.

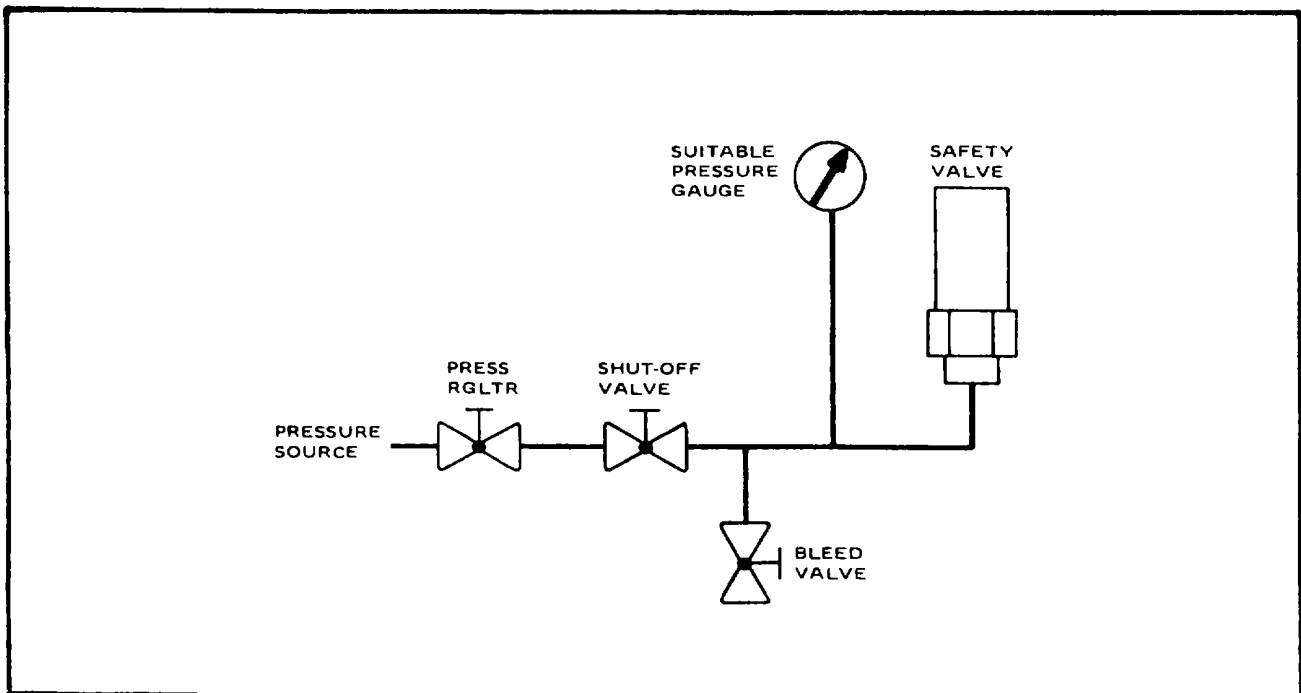

Figure 6-3. Typical Safety Valve Test Setup

d. Repair or Replacement Refer to paragraph 6-3.c. for general repair or replacement procedures.

- (1) Replace damaged or defective nipples, couplings and gauges.
- (2) Replace all threaded parts having worn, stripped, or damaged threads.
- (3) Replace damaged or defective tubing.
- (4) Replace damaged or defective fittings.
- (5) Replace identification plates If damaged, or if markings are illegible.
- (6) Straighten bent or dented panel.
- (7) Replace all parts that are worn or damaged to an extent that will impair their normal function.

e. Assembly To assemble the control panel assembly, proceed as follows.

- (1) If removed, screw adapter (10, Figure 7-4, Sheet 1 of 2) to the air panel mount (21, Figure 7-4, Sheet 2 of 2) Using screws and nuts attach the air panel mount (21) to the panel. Screw cover (9, Figure 7-4, Sheet 1 of 2) on adapter (10).
- (2) Using screws (7) attach the pressure regulator (8) to the control panel
- (3) Insert the service pressure gauge (6) into the panel and attach using the gauge clamp and nuts Insert scuba manifold pressure gauge (1) into control panel and attach using gauge clamp and nuts.

NOTE

Do not fully tighten hand valves or lever valves until tube assemblies are installed.

- (4) If washers (22, Figure 7-4, Sheet 2 of 2) were removed from valves, place washers (22) on valves (5, Figure 7-4, Sheet 1 of 2) and insert valves (5) into the control panel from the rear Attach to the panel using valve holddown nut, attach valve handles to valves and secure with handle nuts

- (5) Position the scuba manifold (26, Figure 7-4, Sheet 2 of 2) with mounts (25) on the rear of the control panel Using screws (3, Figure 7-4, Sheet 1 of 2) attach the manifold (26, Figure 7-4, Sheet 2 of 2) to the panel Position the supply manifold (18) with mounts (25) and attach using screws (3, Figure 7-4, Sheet 1 of 2) and washers (4)
- (6) Insert cam lever valve (2) into the panel from the rear and attach to panel using the cam lever valve (2) holddown nut. Using nuts and clamps, install the gas cylinder pressure gauges (1).
- (7) Position and connect scuba manifold to charging valve tube assemblies (9) Connect scuba manifold to bleed valve tube assembly (6)
- (8) Position and connect scuba manifold to manifold pressure gauge tube assembly (8), and service pressure gauge to pressure regulator tube assembly (7)
- (9) Position and connect scuba manifold shut-off valve to scuba manifold tube assembly (6), and pressure regulator to scuba manifold shut-off valve tube assembly (5).
- (10) Position and connect supply manifold shut-off valve to supply manifold tube assembly (3), and recharge valve to supply manifold tube assembly (3)
- (11) Position and connect cam lever valve to supply manifold tube assembly (2) and cam lever valve to pressure gauge tube assembly (1).



When tightening valves on control panel do not put tube assemblies in a binding position.

- (12) Tighten all cam lever valves (2, Figure 7-4, Sheet 1 of 2) and hand valves (5)

6-7. AIR PURIFICATION CYLINDER GROUP (TYPE I) (See Figure 7-2) The following paragraphs contain disassembly, cleaning, inspection, repair or replacement and assembly instructions for the air purification cylinder group.

- a. Disassembly. Disassemble the air purification cylinder group only to the extent necessary to repair or replace a defective part or parts.

- (1) If tube assemblies (1 and 2) have not been removed, unscrew and remove tube assemblies (1 and 2).
- (2) Unscrew and remove elbows (3).
- (3) Unscrew and remove cylinder cap and upper head subassembly (8 through 18) from cylinder (23) and cartridge (19).
- (4) Remove screws (8), gaskets (9) and dust cover (7) from cap (11).
- (5) Remove retaining ring (10) and separate upper head (13) from cap (11) Remove O-ring (12) from cap (11).
- (6) While holding the upper head (13) and head spring (18), remove retaining screw (14) and disassemble upper perforator (15), lower head (16), head spring (18) and remove O-ring (J 7).

NOTE

Perform step (5) below only when necessary to disassemble lower perforator (21).

- (7) Remove retainer screw (20), lower perforator (21), and spacer (22) from cylinder (23).

b. Cleaning Refer to paragraph 6-3 a for general cleaning instructions.

- (1) Flush the cylinder clean with P-D-680, Type II, or equivalent.
- (2) Clean the upper head with the flushing agent.
- (3) Allow the cylinder, head and parts to air dry until odor of the flushing agent disappears.

c. Inspection. Inspect each part as per paragraph 6-3.b.

- (1) Perforator blades (15 and 21) for any bending or dullness.
- (2) Spring (18) for breaks or set.

d. Repair or Replacement Repair or replacement as per paragraph 6-3.c.

- (1) Replace a damaged cap or cylinder. Damaged threads may cause leakage.

- (2) Replace damaged or dull perforators. Defective perforators will not puncture cartridge.
- (3) Replace a defective spring.
- (4) Replace all parts that are worn or damaged to an extent that will impair their normal function.

e. Assembly. To assemble the air purification cylinder group, proceed as follows:

- (1) Assemble spacer (22) and lower perforator (21) in bottom of cylinder (23) with screw (20) tightened securely.
- (2) To assemble upper head assembly place O-ring (17) in position on lower head (16) Place O-ring (12) in position on upper head (13) Assemble spring (18) and lower head (16) on upper head (13), position upper perforator (15) and secure with screw (12)
- (3) Install this assembled group of parts in cylinder cap (11) and install retaining ring (10) Attach cover (7) to cap (11) with screw gaskets (9) and screws (8)



Do not install cartridge (19) into cylinder until ready for use Contamination of the cartridge could result from premature cartridge installation.

- (4) Install cartridge (19) in cylinder (23) and screw the upper head assembly securely onto cylinder (23) hand tight
- (5) The upper and lower mounting brackets (6 and 5) are supplied with a dehydrator assembly. Attach the brackets (6 and 5) to cylinder (23) until ready for next higher assembly.

6-8. CONTROL PANEL ASSEMBLY, TYPE II (AIR/OXYGEN) (See Figure 7-5) The following paragraphs contain disassembly, cleaning, inspection, repair or replacement and assembly instructions for the Type II control panel assembly.

a. Type 11 - Air section of the Type II Control Panel.

NOTE

See paragraph 6-6 for disassembly procedures on the air section of the Type II panel Figure 7-5 shall be referred to for component location Follow number sequence for disassembly and assembly.

b. Type II - Oxygen section of the Type II control panel (see Figure 7-5)

WARNING

Any disassembly, cleaning, inspection, repair or replacement and assembly of a part or parts of an oxygen system shall be done in a contaminant free area.

(a) Disassembly Disassemble the oxygen section of the Type II control panel only to the extent necessary to repair or replace a defective part or parts.

NOTE

Tag tube assemblies for re-assembly purposes.

- (1) Disconnect and remove cam lever valve to pressure gauge tube assemblies (1, Figure 7-5, Sheet 2 of 2).
- (2) Disconnect and remove cam lever valve to supply manifold tube assemblies (2).
- (3) Disconnect and remove recharge valve to supply manifold tube assembly (4), and recharge valve to oxygen panel mount tube assembly (3).
- (4) Disconnect and remove supply manifold to supply manifold shut-off valve tube assembly (5).
- (5) Disconnect and remove pressure regulator to service pressure gauge tube assembly (7).
- (6) Disconnect and remove pressure regulator to scuba manifold shut-off valve tube assembly (6) Disconnect and remove shutoff valve to scuba manifold tube assembly (8).

- (7) Disconnect and remove scuba manifold to bleed valve tube assembly (9).
- (8) Disconnect and remove scuba manifold to charging valve tube assemblies (10). Disconnect and remove scuba manifold to scuba manifold pressure gauge tube assembly (11).
- (9) Loosen and remove oxygen cylinder pressure gauge (13, Figure 7-5, Sheet 1 of 2) mounting screws and nuts Remove gauge (13) from panel.
- (10) Loosen and remove cam lever valve (14) holddown nut, and remove valve with washer (18) from the rear of the panel.
- (11) Remove screws (17), and cap (15) from oxygen recharge panel mount (23, Figure 7-5, Sheet 2 of 2) Remove oxygen panel mount from rear of panel Remove adapter (16, Figure 7-5, Sheet 1 of 2) from mount.
- (12) Remove screws (18) and washers (19) from oxygen supply manifold (24, Figure 7-5, Sheet 2 of 2) and scuba manifold (28) Remove manifolds from the rear of the panel Remove manifold mounts (20), and safety valves (21) from the manifolds Remove connectors (19, 22 and 27) from the supply and scuba manifolds.
- (13) Loosen and unscrew valve (20, Figure 7-5, Sheet 1 of 2) retaining nut Pull handle of valve steadily outward, while steadying the back portion of the valve Remove rear sections of the valve with washer (25) from the panel.
- (14) Remove pop off cap from handle of oxygen pressure regulator (22), remove nut and handle, remove screws (21) from panel mount and remove regulator from the rear of the panel.
- (15) Loosen and remove mounting screws and nuts to oxygen regulator pressure gauge (23) Remove gauge.
- (16) Loosen and remove screws and nuts to scuba manifold pressure gauge (24). Remove gauge

b. Inspection:

- (1) Type II (Air) Section of Control Panel - See paragraph 6-6.c. for Inspection instructions

- (2) Type II (Oxygen) Section of Control Panel. General Inspection instructions are as follows

WARNING

Inspect a part or parts of an oxygen system in a clean contaminant free environment.

- (a) Check for damaged gauges
- (b) Damaged cam lever or head valves
- (c) Damaged or cracked hardware, fittings, steel tubing and flex hoses

WARNING

SAFETY VALVE TESTING system must be oxygen clean

- (3) Test Safety Valves Connect oxygen safety valve to be tested to an oxygen cleaned gauge and regulated 3800 psig (26,182 kPa) clean nitrogen source (See Figure 6-4)

WARNING

Keep unprotected parts of body away from valve opening during test

NOTE

Hydrostatic tester may be used in lieu of nitrogen or air pressure source.

- (a) Starting with zero pressure increase pressure to valve operating pressure
 - (b) If safety valve relieves pressure prior to, or after specified pressure and cannot be reset, safety valve is defective
- c. Repair or Replacement Refer to paragraph 6-3.c. for general repair or replacement procedures.
- (1) Replace damaged or defective nipples, couplings and gauges.
 - (2) Replace all threaded parts having worn, stripped or damaged threads.

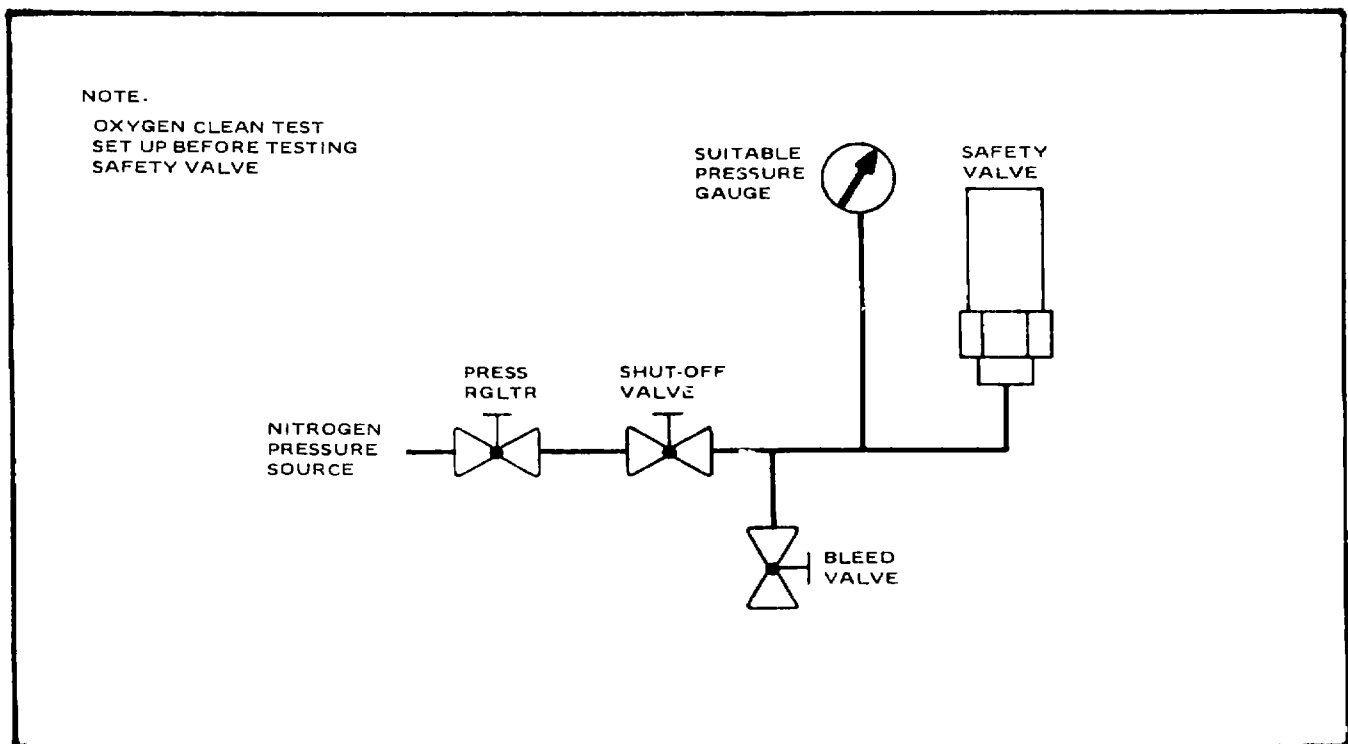

Figure 6-4. Typical Safety Valve Test Setup (Oxygen)

c. Repair or Replacement Refer to paragraph 6-3.c. for general repair or replacement procedures.

- (1) Replace damage or defective nipples, couplings and gauges.
- (2) Replace all threaded parts having worn, stripped or damaged threads.
- (3) Replace damaged or defective tubing or flex hoses.
- (4) Replace damaged or defective fittings.
- (5) Replace identification plates If damaged or if markings are illegible.
- (6) Straighten bent or dented panel (sheet metal).
- (7) Replace all parts that are worn or damaged to an extent that will Impair their normal function.

d. Cleaning

- (1) All parts or components of parts that make up the Type II Oxygen System shall be oxygen leaned prior to their assembly.
- (2) Parts shall be cleaned and handled in a contaminant free environment.

e. Assembly. To assemble the Type 11, Oxygen Section of the control panel, proceed as follows (see Figure 7-5).



All components and parts of the oxygen system shall be oxygen clean, and shall be assembled in a clean contaminant free environment using approved oxygen clean assembly procedures.

- (1) Install manifold pressure gauge (24, Figure 7-5, Sheet 1 of 2) and secure to panel using gauge mounting screws and nuts.
- (2) Install the oxygen regulator pressure gauge (23) and secure to panel using gauge mounting screws and nuts.
- (3) Using screws (21) attach the oxygen pressure

regulator (22) to the panel, place regulator handle on stem and secure with the stem nut, install pop-off cap in the handle.

NOTE

Install all tubing before fully tightening valves and manifolds.

- (4) Insert the rear section of the valves (20) with washers (25) through the back of the panel, insert the stem of the front section of the valve into the valve from the front of the panel and secure valve by tightening the retaining nut.
- (5) Install connectors (19, 22 and 27) in supply and scuba manifolds (24, 28, Figure 7-5, Sheet 2 of 2) Install the connectors as per Figure 7-5 Sheet 2 of 2). Install safety valves (21) on connectors (22) Position manifold mounts (20) on manifolds (24, 28). Using washers (19, Figure 705, Sheet 1 of 2) and screws (18) Install the manifolds on the control panel.
- (6) Install adapter (16, Figure 7-5, Sheet 1 of 2) to the oxygen recharge panel mount (23, Figure 7-5, Sheet 2 of 2). Using screws (17, Figure 7-5, Sheet 1 of 2) install panel mount to the panel. Screw cap (15) on adapter (16).
- (7) Install cam lever valves (14) with washers (18) through the rear of the panel and secure to panel using the valve holddown nut
- (8) Using gauge mounting screws and nuts, install oxygen cylinder pressure gauge (13).
- (9) Position and connect scuba manifold to scuba manifold pressure gauge tube assembly (11, Figure 7-5, Sheet 2 of 2) Position and connect scuba manifold to charging valve tube assemblies (10).
- (10) Position and connect scuba manifold to bleed valve tube assembly (9).
- (11) Position and connect shut-off valve to scuba manifold tube assembly (8).
- (12) Position and connect pressure regulator to scuba manifold shut-off valve tube assembly (6).

- (13) Position and connect pressure regulator to service pressure gauge tube assembly (7).
- (14) Position and connect supply manifold to supply manifold shut-off valve tube assembly (5).
- (15) Position and connect oxygen recharge panel mount to recharge valve tube assembly (3) Position and connect the recharge valve to supply manifold tube assembly (4).
- (16) Position and connect cam lever valve to supply manifold tube assembly (2).
- (17) Position and connect cam lever valve to oxygen gas cylinder pressure gauge tube assembly (1).

WARNING

Do NOT place unwanted torque on tube assemblies when valves and manifolds are tightened on panel.

- (18) Tighten supply and scuba manifolds and valves Check to be sure that no tube assembly has been placed in an unusual bind.

6-9. AIR/OXYGEN PURIFICATION CYLINDER GROUPS-TYPE II (AIR/OXYGEN) SERVICING UNITS
(See Figures 7-2 and 7-3). The following paragraphs contain disassembly, cleaning, inspection, repair or replacement and assembly instructions for the Type II (Air/Oxygen) Purification Cylinders Group.

a. Type II (Air/Oxygen) Servicing Unit - Type I (Air) Purification Cylinder Group (See Figure 7-2).

- (1) See paragraph 6-7, Air Purification Cylinder Group (Type I) for disassembly, cleaning, inspection, repair or replacement, and assembly instructions.

b. Type 11 (Air/Oxygen) Servicing Unit - Type II (Oxygen) Purification Cylinder Group (See Figure 7-3).

- (1) Disassembly Disassemble the oxygen purification cylinder group only to the extent necessary to repair or replace a defective part or parts.

WARNING

Any disassembly, cleaning, inspection, repair or replacement and assembly of a part or parts of an oxygen system shall be done in a contaminant free area.

- (a) If tube assemblies (1 and 2) have not been removed, unscrew and remove tube assemblies (1,2).
- (b) Unscrew and remove elbows (3).
- (c) Unscrew and remove cylinder cap and upper head subassembly (3 through 14) from cylinder (19) and cartridge (15).
- (d) Remove screws (4), gaskets (5) and dust cover from cap (7).
- (e) Remove retaining ring (6) and separate upper head (9) from cap (7) Remove o-ring (8) from cap (7).
- (f) While holding the upper head (9) and head spring (14), remove retaining screw (10) and disassemble upper perforator (11), lower head (12), head spring (14) and remove o-ring (13).

NOTE

Perform step (5) only when necessary to disassemble lower perforator (17).

- (g) Remove retainer screw (16), lower perforator (17), and spacer (18) from cylinder (19).
- (2) Inspection Refer to paragraph 603 b for general inspection procedures
 - (a) Perforator blades (11 and 17) for any bending or dullness (b) Spring (14) for breaks or set.
- (3) Repair or Replacement Refer to paragraph 6-3.c for general repair or replacement procedures
 - (a) Replace a damaged cap or cylinder Damaged threads may cause leakage.
 - (b) Replace damaged or dull perforators Defective perforators will not puncture cartridge.

- (c) Replace a defective spring.
- (d) Replace all parts that are worn or damaged to an extent that will impair their normal function.

(4) Cleaning.

- (a) All parts or components of parts that make up the Type II oxygen purification cylinder group (Figure 7-3) shall be oxygen cleaned prior to their assembly
- (b) Parts shall be cleaned and handled in a contaminant free environment.

(5) Assembly. To assemble the oxygen purification cylinder group, proceed as follows



All components and parts of the oxygen system (Type II) shall be oxygen clean, and shall be assembled in a clean contaminant free environment, using approved oxygen clean assembly procedures.

- (a) Assemble spacer (22) and lower perforator (21) in bottom of cylinder (23) with screw (20) tightened securely
- (b) To assemble upper head assembly place O-ring (17) in position on lower head (16) Place O-ring (12) in position on upper head (13). Assemble spring (18) and lower head (16). Assemble spring (18) and lower head (16) on upper head (13), position upper perforator (15) and secure with screw (14).

- (c) Install this assembled group of parts in cylinder cap (11) and install retaining ring (10) Attach cover (7) to cap (11) with screw gaskets (9) and screws (8).



Do NOT install cartridge (19) into cylinder (23) until ready for use Contamination of the cartridge could result from premature installation.

- (d) Install cartridge (19) in cylinder (23) and screw the upper head assembly securely onto cylinder (23) hand tight.
- (e) The upper and lower mounting brackets (6 and 5) are supplied with a dehydrator assembly Attach the brackets (6 and 5) to cylinder (23) until ready for next higher assembly.

6-10. TEST. The following paragraphs contain the information for testing system (Type I [Air] or Type II [Air/Oxygen]) integrity.

- a. Type I (Air) test Refer to Section IV, paragraph 4-7 and proceed with unit operation
- b. Type II (Air/Oxygen) test Refer to Section IV, paragraph 4-7 and proceed with unit operation.

SECTION VII.

ILLUSTRATED PARTS BREAKDOWN

7-1. MODEL COVERED. This Illustrated parts breakdown covers the Model DMC-AA, diesel engine driven, skid mounted air compressor. The unit is manufactured by Davey Compressor Company (FSCM 16004), Cincinnati, Ohio 45242. Part numbers 83208 and 83209 are assigned to Type I and Type II units respectively.

7-2. PARTS THAT ARE LISTED. In general, the assemblies and parts installed at the time the end items were manufactured are listed and identified in this manual. When an assembly or part (including vendor items), which is different from the original, is installed during repair, the assembly or part must match form, fit and function. Interchangeable and substitute assemblies and parts are not listed in this manual. When a standard size part can be replaced with an oversize or undersize part, the latter parts, showing sizes, are also listed.

7-3. LISTING OF SIMILAR ASSEMBLIES. When similar assemblies contain approximately 51% or more of identical parts, the assemblies are combined and listed as follows:

a. The assemblies are listed first followed by detail parts.

b. A part common to all assemblies in the same quantity is listed once.

c. A part common to all assemblies in differing quantities is listed once for each quantity and identified to which assembly each listing pertains.

d. Parts peculiar to an assembly are listed once and identified to which assembly each pertains.

7-4. SYMBOLS AND ABBREVIATIONS. Symbols and abbreviations used in the MPL are in accordance with Military Standard, MIL-STD-12, or are defined below:

(AP) - This abbreviation, found in the description column, indicates the part is an "attaching part" for the next higher assembly or part.

AR - This abbreviation stands for "as required"

This symbol, inserted flush right following a part number in the MPL for Government Furnished Equipment (GFE) and Contractor Furnished Equipment (CFE), means that detail parts are listed in a separate manual. Refer to "Related Publications" paragraph of this Introduction for publication number, when applicable.

7-5. FEDERAL SUPPLY CODES FOR MANUFACTURERS (FSCM). These five digit code numbers are used to identify the actual manufacturer of vendor items used in this equipment. The code appears in parentheses in the Description column following the description of the part involved. The applicable codes are listed below. The prime contractor's code is also listed below. The absence of a manufacturer's code in the Description column of the MPL means that the part is the end item manufacturer's part number or commercial off-the-shelf type items that should be ordered by complete description. The following codes have been excerpted from Cataloging Handbook H4-1 and H4-2, Federal Supply Code for Manufacturers:

CODE	MANUFACTURER'S NAME AND ADDRESS
------	---------------------------------

16004	Davey Compressor Company 11060 Kenwood Road Cincinnati, OH 45242
-------	--

16166	Western Enterprises 33672 Pin Oak Pky. Avon Lake, OH 44012
-------	--

24617	General Motors Corp. 3044 Grand Blvd. W Detroit, MI 48202
-------	---

25609	Dacor Corp. 161 Northfield Rd Northfield IL 60093
-------	---

33538	Tescom Corp. 2600 Niagara Lane North, P O Box 1434 Minneapolis, MN 55441
-------	--

- | | | | |
|-------|---|--|--|
| 38056 | Ashcroft (Dresser Industries)
Dresser Industries Valve and Industrial Div.
250 E. Main St.
Stratford, CT 06497 | 88189 | Taylor-Wharton Co.
Div of Harsco Corp.
2900 William Penn Hwy.
Easton, PA 18042 |
| 38508 | Marsh Instrument Co.
Unit of General Signal Corp.
3501 W. Howard St.
P.O. Box 1011
Skokie, IL 60076 | 89073 | Rexarc Inc.
East Third St.
P O Box 47
West Alexandria, OH 45381 |
| 54938 | Parker-Hannifin Corp.
Huntsville CPI Facility
9400 S. Memorial Pky.
Huntsville, AL 35082 | 91816 | James Pond and Clark Div
Circle Seal Corp.
P O Box 3666
Anaheim, CA 92803 |
| 79470 | Weatherhead Co., The
300 East 131 st Street
Cleveland, OK 44108 | 98660 | Flodar Corp., Div of
Alco Standard Corp.
16911 St. Clair Ave.
Cleveland, OH 44110 |
| 82990 | Aero-Dri Corp.
11060 Kenwood Dr.
Cincinnati, OH 45242 | <p>7-6. USABLE ON CODES. Not used in this publication.</p> <p>7-7. RELATED PUBLICATIONS. Publications used in conjunction with this Illustrated Parts Breakdown are.</p> <p style="padding-left: 40px;">TM 9-2330-202-14P - Operator, Organizational, and Field Maintenance Instructions, Repair Parts and Special Tools List for Chassis Trailer, 3/4 Ton, 2-wheel, M 16 and M116A1</p> | |
| 88044 | Aeronautical Standards Group
Dept. of Navy and Air Force
Silver Springs, MD 20900 | | |

HOW TO USE THE ILLUSTRATED PARTS BREAKDOWN

IF YOU *Don't* KNOW THE PART NUMBER ...

Do This

TABLE OF CONTENTS	
Page	Section
1	INTRODUCTION
2	HOW TO USE THIS MANUAL
3	GENERAL INFORMATION
4	SAFETY PRECAUTIONS
5	OPERATION
6	MAINTENANCE
7	REPAIR
8	ADJUSTMENT
9	TESTING
10	TRUBLESHOOTING
11	REVISIONS
12	INDEX
13	APPENDICES
14	FIGURE INDEX
15	ASSEMBLY LIST
16	EXPLODED VIEW
17	WIRING DIAGRAM
18	SCHEMATIC DIAGRAM
19	PHOTOGRAPHS
20	ILLUSTRATED PARTS BREAKDOWN

Blowdown valve assembly . . . 2-20

1 Refer to illustration list and select the illustration most likely to contain the desired part.

2 Refer to the page number indicated and find desired part on illustration.

3 Note the Figure Number of the illustration and the Index Number of the part. Refer to the corresponding Figure-Index Number on the Assembly List page for Part Number, Nomenclature, etc.

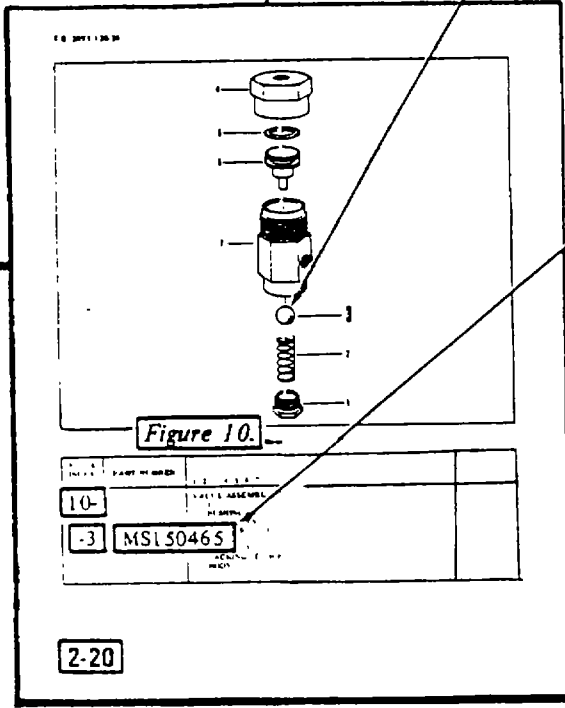

Figure 7-0. How to Use Illustrated Parts Breakdown, Example.

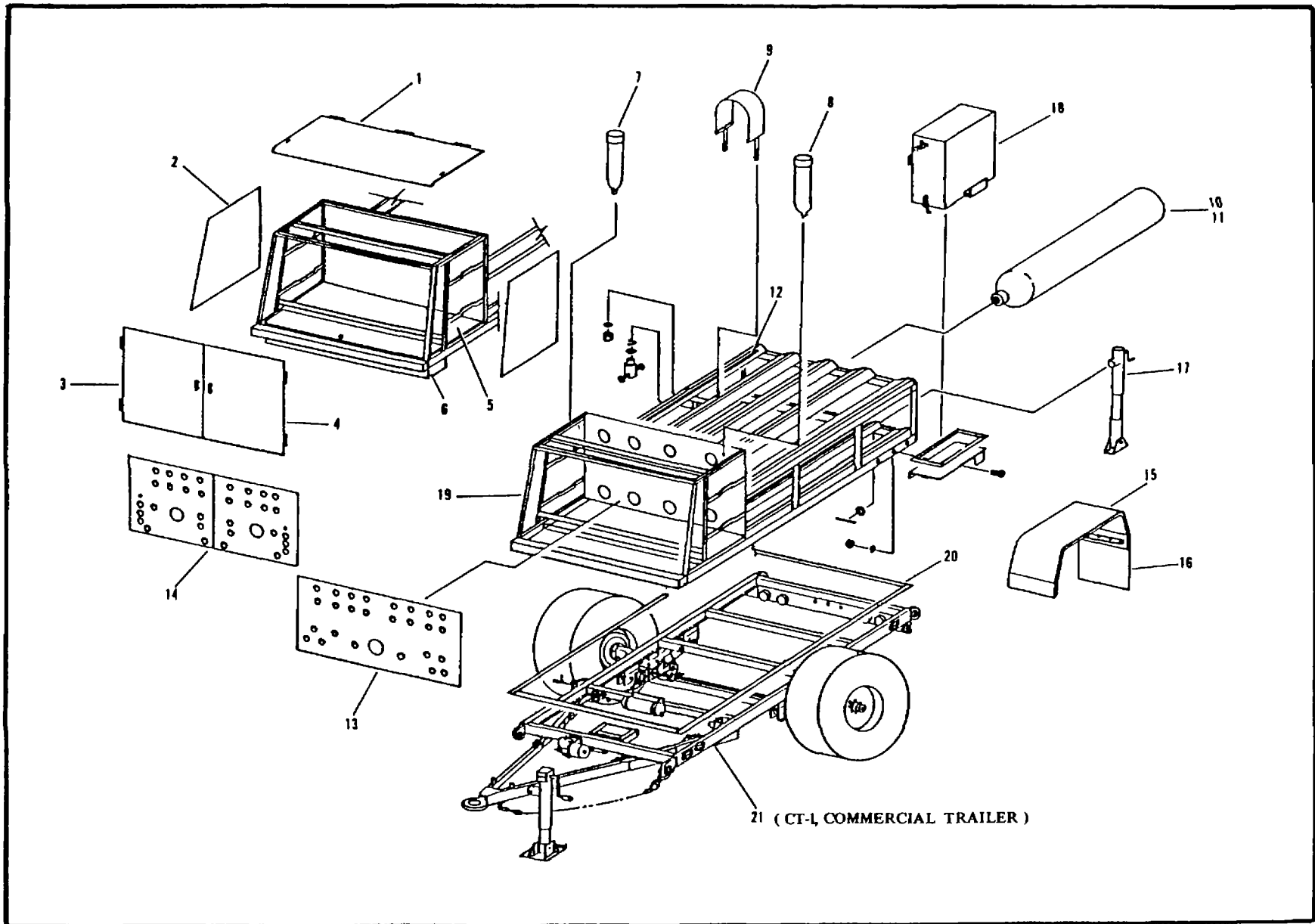

Figure 7-1. Service Unit, Type I (Air) and Type II (Air/Oxygen).

FIGURE & INDEX NUMBER	PART NUMBER	DESCRIPTION						QTY PER ASSY	USABLE ON CODE
		1	2	3	4	5	6		
7-1	83208	SERVICING UNIT - TYPE I (AIR)						REF	
	83209	SERVICING UNIT - TYPE II (AIR/OXYGEN)						REF	
-1	83717	. COVER, Top, hinged.....						1	
	443331	. . NUT, Lock, 1/4-20 (AP) (24617)						6	
	120392	. . WASHER, Flat, 1/4 (AP) (24617)						6	
	9419376	. . SCREW, Serr hd, 1/4-20x 1 (AP) (24617)						6	
-2	83687	. PANEL, Side						2	
	9416918	. . NUT, Serr. fig, 1/4- 20 (AP) (24617)						22	
	273771	. . SCREW, Serr, fig. hd., 1/4-20 x 1/2 lg. (AP) (24617)						22	
-3	83759	. DOOR, Panel						1	
	443331	. . NUT, Lock, 1/4-20 (AP) (24617)						4	
	67919	. . WASHER, Flat, 1/4 (AP) (24617)						4	
	115002	. . SCREW, Flat hd, 1/4-20 x 5/8 lg. (AP) (24617)						4	
-4	83758	. DOOR, Panel						1	
	443331	. . NUT, Lock, 1/4-20 (AP) (24617)						4	
	67919	. . WASHER, Flat, 1/4 (AP) (24617)						4	
	115002	. . SCREW, Flat hd, 1/4-20x 5/8 lg. (AP) (24617)						4	
	132696	. . SCREW, Rd. hd. mach, 6032 x 3/8 lg. (AP) (24617)						4	
	427254	. . NUT, Lock, 6-32 (AP) (24617)						4	
	83473	. . LATCH, Spring-door.....						2	
-5	83747	. UNDERSHIELD						1	
	443331	. . NUT, Lock, 1/4-20 (AP) (24617)						12	
	120392	. . WASHER, Flat, 1/4 (AP) (24617)						12	
	274825	. . SCREW, Hex hd, 1/4-20 x 3/4" (AP) (24617).....						12	
-6	83748	. TOOL BOX.....						1	
	443331	. . NUT, Lock, 1/4-20 (AP) (24617)						12	
	120392	. . WASHER, Flat, 1/4 (AP) (24617)						12	
	274473	. . SCREW, Hex hd, 1/4-20 x 5/8 lg. (AP) (34617)						12	
	82507	. . KNOB, Tool box hd						1	
	66373	. . DOOR, Catch and strike ass'y.....						2	
	454745	. . SCREW, Truss hd, 1/4-28 x 1/2 lg. (AP) (24617)						3	
	443332	. . NUT, Lock, 1/4-28 (AP) (24617)						3	
	120392	. . WASHER, Flat 1/4 (AP) (24617)						3	
-7	No Number	. AIR PURIFICATION CYLINDER GROUP TYPE I SYSTEMS						1	
		. (See Figure 7-2 for breakdown)							
	443335	. . NUT, Lock, 3/8-16 (AP) (24617)						4	
	120394	. . WASHER, Flat, 3/8 (AP) (24617)						4	
	122145	. . SCREW, Hex hd cap 3/8-16 x 1-1/4 lg. (AP) (24617)						4	
-8	No Number	. OXYGEN PURIFICATION CYLINDER GROUP,							
		. . TYPE II Only						1	
		. (See Figure 7-3 for breakdown)							
	443332	. . NUT, Lock, 3/8-16 (AP) (24617)						4	
	120394	. . WASHER, Flat 3/8 (AP) (24617)						4	
	122145	. . SCREW, Hex hd cap 3/8-16 x 1-1/4" lg. (AP) (24617)						4	
-9	83770	. BAND, Clamping, gas cylinder						8	
	83771	. . NUT, Clamping (AP).....						8	
	83975	. . SPACER (AP)						8	
	83774	. . RING, Retaining (AP)						8	
	83772	. . HANDLE(AP)						8	
	83773	. . KNOB, Ball (AP).....						16	
	443339	. . NUT, Lock, 1/2- 13 (AP) (24617)						16	
-10	83519	. CYLINDER, Air, assembly, 3500 psi., Type I Systems (Air) ..						12	
	83523	. FLEX HOSE ASSY, CGA346							
		. . TYPE I, (Air).....						8	
		. . TYPE II, (Air/Oxygen).....						4	
-11	83492	. CYLINDER, Oxygen, 2265 psi. Type II Systems (Oxygen)....						4	
	83518	. . VALVE, Cylinder, oxygen						4	
	83549	. FLEX HOSE ASSY CGA-540 (Oxygen).....						4	
-12	83764	. STRIP, Wear.....						8	
	9416918	. . NUT, Hex, ser, fig lock, 1/4-20						80	
	133733	. . SCREW, Flat hd, 1/4-20 x 3/4 (AP) (24617)						80	
-13	83887	. PANEL, Control, Air, Type I (see Figure 7-4 for breakdown)						1	
	9416918	. . NUT, Hex, serr. fig, 1/4-20 (AP) (24617).....						16	
	273771	. . SCREW, Serr fig hd 1/4-20x 1/2 lg (AP) (24617).....						16	
-14	83888	. PANEL CONTROL, Air/Oxygen, Type II.....						1	
		. (See Figure 705 for breakdown)							
	9416918	. . NUT, Hex serr. fig 1/4-20 (AP) (24617).....						16	

FIGURE & INDEX NUMBER	PART NUMBER	DESCRIPTION	QTY PER ASSY	USABLE ON CODE
7-15	273771	. . SCREW, Serr fig. hd, 1/4-20 x 1/2 lg. (AP) (24617)	16	
	83730	. FENDER ASSEMBLY, Welded (USE WITH M116A1 TRAILER).....	2	
-16	85948	. FENDER ASSEMBLY, Welded (USE WITH CT-1 TRAILER)	2	
	443335	. . NUT, Lock, 3/8-16 (AP) (24617)	8	
	120394	. . WASHER, Flat, 3/8 (AP) (24617)	8	
	122145	. . SCREW, Hex hd, 3/816 x 1-1/4 (AP) (24617)	8	
	83794	. GUARD, Splash (USE WITH FENDER 83730)	2	
	85953	. GUARD, Splash (USE WITH FENDER 85948)	2	
	443335	. . NUT, Lock, 3/8-16 (AP) (24617)	8	
	120394	. . WASHER, Flat, 3/8 (AP) (24617)	16	
	83541	. . PLATE, Back-up (USE WITH FENDER 83730).....	2	
	85947	. . PLATE, Backup (USE WITH FENDER 85948).....	2	
-17	122145	. . SCREW, Hex hd cap 3/8-16 x 1-1/4 lg. (AP) (24617)	8	
	83973	. JACK, Welded, ass'y.....	1	
-18	84520	. . PIN, Roll 5/16 x 2-1/2 lg.....	1	
	No Number	. TROUGH SERVICE GROUP	REF	
-19	84812	. . TROUGH, Service.....	2	
	82663	. . VALVE, Drain	2	
	132636	. . SCREW, Rd hd, 4-40x 3/8 (AP) (24617)	16	
	131043	. . WASHER, Lock, No 4 (AP) (24617)	16	
	60725	. . PLATE, Nut, 4-40	2	
	47156	. . LATCH, Over-center.....	2	
	14048	. . WEBBING, Fabric	AR	
	84811	. . SUPPORT, Trough.....	1	
	84895	. . SUPPORT, Trough.....	1	
	120214	. . NUT, Hex, 5/16-18 (AP) (24617)	6	
	120376	. . WASHER, Lock, 5/16 (AP) (24617).....	6	
	122017	. . SCREW, Hex hd, 5/16-18 x 1 lg. (AP) (24617)	6	
	83686	. FRAME, Welded	1	
	27327	. . LATCH, Eye (AP)	6	
	27329	. . SPRING, Latch.....	6	
27328	. . BRACKET, Latch	6		
68457	. . REPAIR KIT, Field, latch	AR		
272683	. . NUT, Lock, 7/16-14 (AP) (24617)	10		
120395	. . WASHER, Flat, 7/16 (AP) (24617)	20		
122253	. . SCREW, Hex hd, 7/16-14 x 1 lg. (AP) (24617).....	10		
-20	14048	. WEBBING, Fabric	AR	
-21	MS53028-1	. CHASSIS, Trailer, 3/4 ton, M116A1 (Government furnished)	1	
	86169	. COMMERCIAL TRAILER, CT-1 (See Chapter II, Figure 7-1 for breakdown)	1	

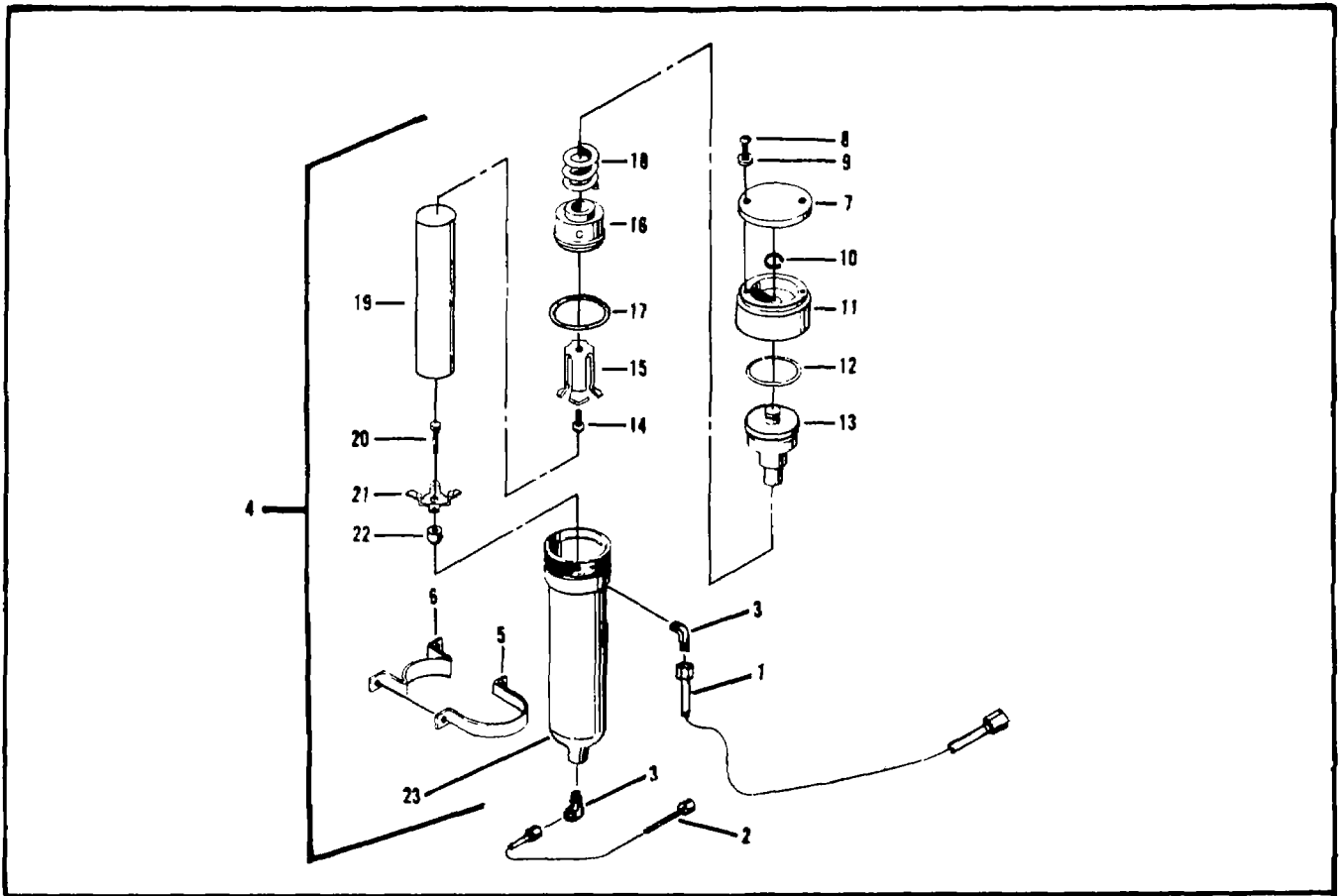

Figure 7-2. Air Purification Cylinder Group, Type I

FIGURE & INDEX NUMBER	PART NUMBER	DESCRIPTION	QTY							USABLE ON CODE	
			1	2	3	4	5	6	7		PER ASSY
7-2	No Number	AIR PURIFICATION CYLINDER GROUP, Type I								REF	
		(see Figure 7-1 for NHA)									
-1	83528	. TUBE ASSEMBLY, Control panel to cylinder								1	
-2	83530	. TUBE ASSEMBLY, Cylinder to control panel								1	
-3	28842	. ELBOW, Male, 1/4NPT x 1/4 T (24617)								2	
-4	82991	. DEHYDRATOR CYLINDER ASSY, Air (82990) (65353)								1	
-5	83006	. BRACKET, Mounting, upper (82990).....								2	
-6	83005	. BRACKET, Mounting, lower (82990).....								2	
-7	82993	. COVER, Dust (82990).....								1	
-8	83008	. SCREW, Mach. (AP) (82990).....								2	
-9	83009	. GASKET, Cover screw (AP) (82990).....								1	
-10	82995	. RING, Retaining (82990).....								1	
-11	82994	. CAP, Cylinder (82990).....								1	
-12	AN6227-36	. PACKING, Preformed, O-ring (88044).....								1	
-13	82996	. HEAD, Upper (82990)								1	
-14	83000	. SCREW, Hex hd, upper perf rtnr (82990).....								1	
-15	82999	. PERFORATOR, Upper (82990).....								1	
-16	82997	. HEAD, Lower (82990)								1	
-17	AN6227-35	. PACKING, Preformed, O-ring (88044).....								1	
-18	82998	. SPRING, Head (82990).....								1	
-19	MA-2	. CARTRIDGE, Oxy punfier (82990) (MIL-C4952).....								1	
-20	83002	. SCREW, Hex hd, (82990)								1	
-21	83003	. PERFORATOR, Lower (82990).....								1	
-22	83004	. SPACER, Pepf, lower (82990).....								1	
-23	82992	. CYLINDER, Dehydrator (82990).....								1	

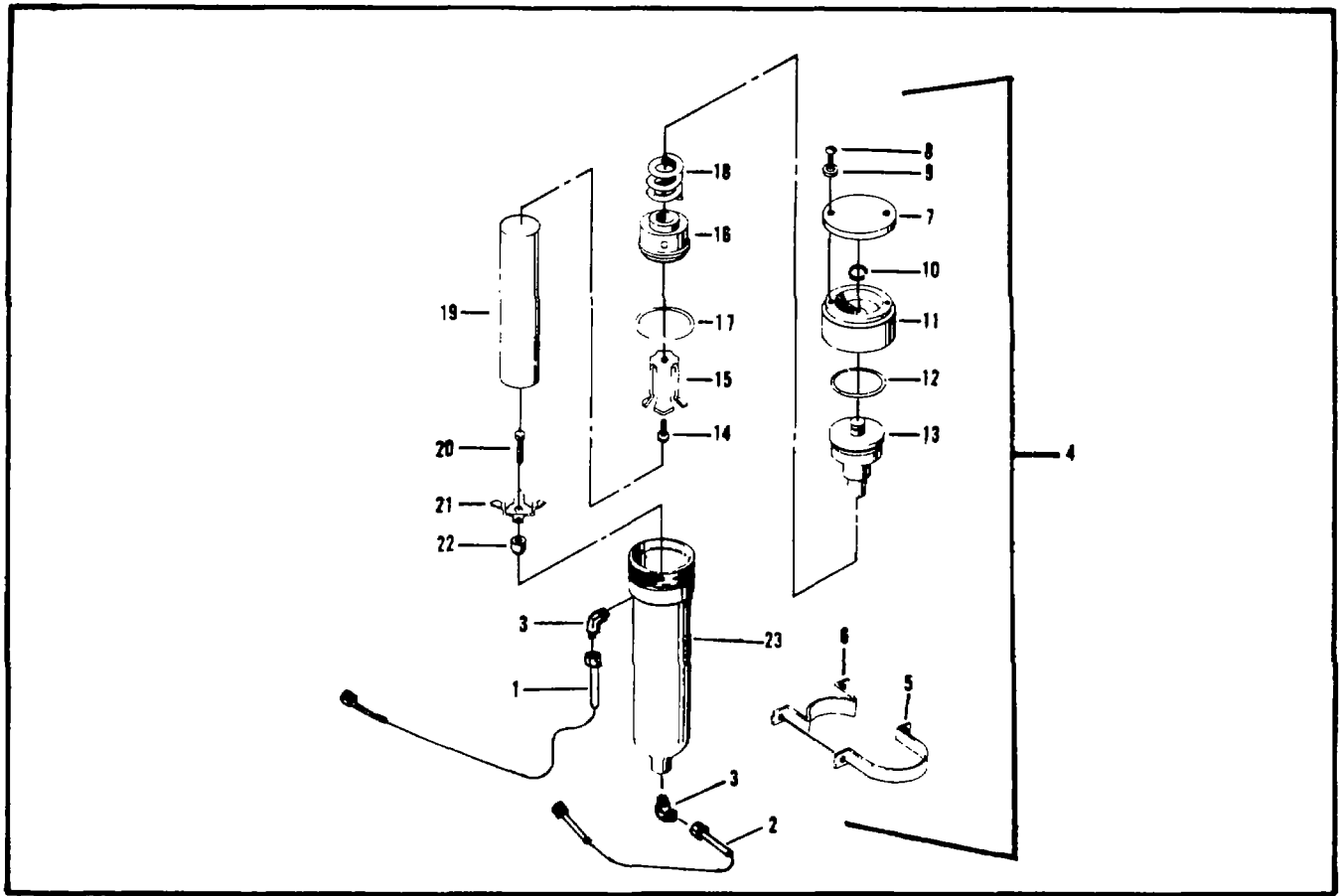

Figure 7-3. Oxygen Purification Cylinder Group, Type II.

FIGURE & INDEX NUMBER	PART NUMBER	DESCRIPTION	1 2 3 4 5 6 7							QTY PER ASSY	USABLE ON CODE
			1	2	3	4	5	6	7		
7-3	No Number	OXYGEN PURIFICATION CYLINDER GROUP, Type II only								REF	
-1	83537	. TUBE ASSEMBLY, Control panel to cyl								1	
-2	83540	. TUBE ASSEMBLY, Cyl to control panel								1	
-3	83899	. ELBOW, Male, 1/4NPT x 5/6 T(24617)								2	
-4	OXY-82991	. DEHYDRATOR CYLINDER ASSY, Oxygen (82990) (85467)								1	
-5	83006	. BRACKET, Mounting, upper (82990).....								2	
-6	83005	. BRACKET, Mounting, lower (82990)								2	
-7	OXY-82993	. COVER, Dust (82990).....								1	
-8	OXY-83008	. SCREW, Mach, (AP) (82990).....								2	
-9	OXY-83009	. GASKET, Cover screw (AP) (82990).....								1	
-10	OXY-82995	. RING, Retaining (82990).....								1	
-11	OXY-82994	. CAP, Cylinder (82990).....								1	
-12	OXY-AN6227-36	. PACKING, Preformed, O-ring (88044).....								1	
-13	OXY-82996	. HEAD, Upper (82990)								1	
-14	OXY-83000	. SCREW, Hex hd, upper perf rtrnr (82990)								1	
-15	OXY-82999	. PERFORATOR, Upper (82990).....								1	
-16	OXY-82997	. HEAD, Lower (82990)								1	
-17	OXY-AN6227-35	. PACKING, Preformed, o-ring (88044)								1	
-18	OXY-82998	. SPRING, Head(82990)								1	
-19	MA-2	. CARTRIDGE, Oxy purifier (82990) (MIL-C-4952).....								1	
-20	OXY-83002	. SCREW, Hex hd, (82990)								1	
-21	OXY-83003	. PERFORATOR, Lower (82990).....								1	
-22	OXY-83004	. SPACER, Pepf, lower (82990).....								1	
-23	OXY-82992	. CYLINDER, Dehydrator (82990).....								1	

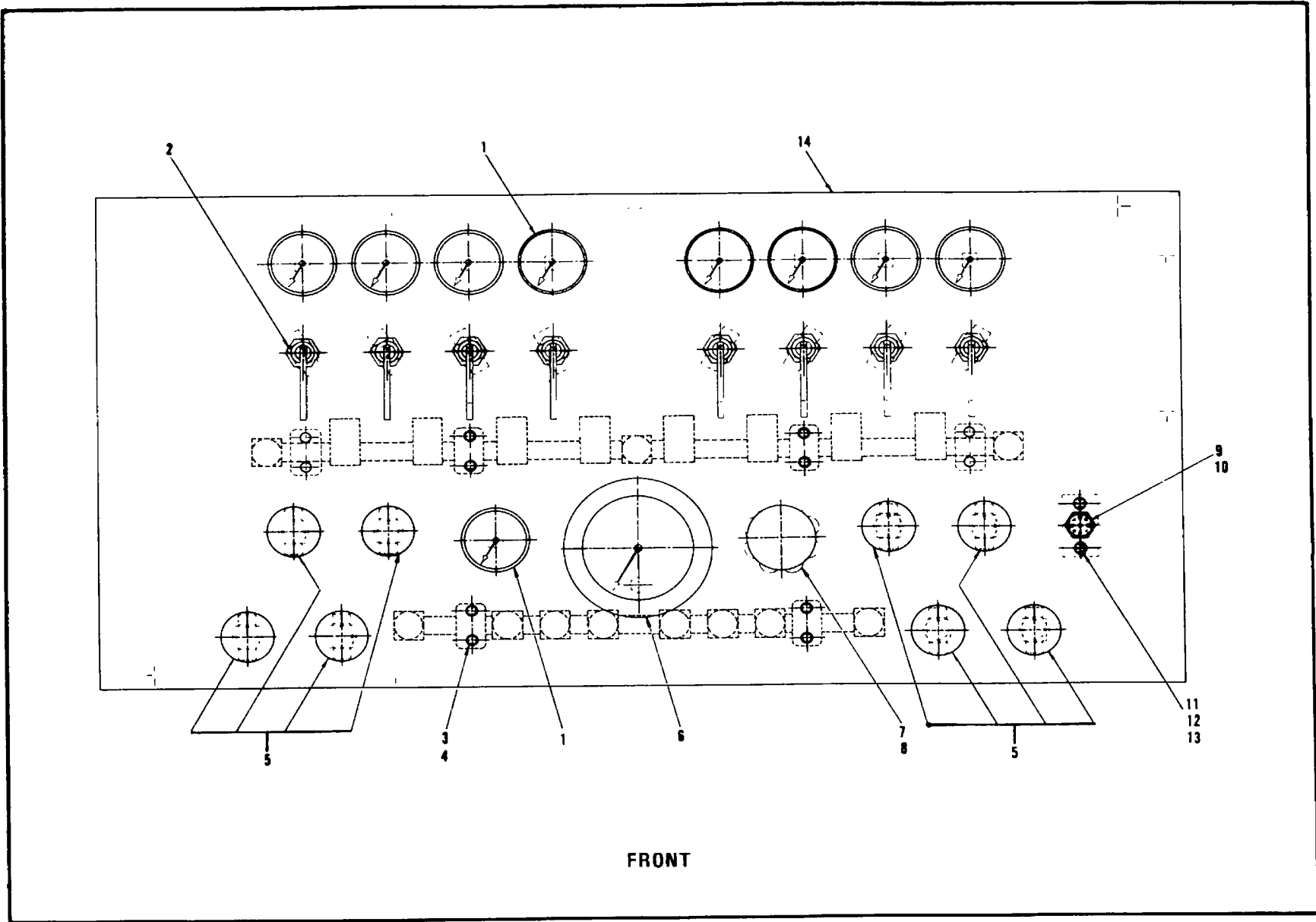

Figure 7-4. Control Panel, Air, Type I (Sheet 1 of 2).

FIGURE & INDEX NUMBER	PART NUMBER	DESCRIPTION							QTY PER ASSY	USABLE ON CODE
		1	2	3	4	5	6	7		
7-4-	83887	CONTROL PANEL ASSY, Air, Type I (Sheet 1 of 2).....							REF	
-1	65165	. GAUGE, Pressure.....							9	
-2	83382	. VALVE, Cam lever.....							8	
-3	121940	. SCREW, Hex hd, 1/4-20 x 1-1/4.....							12	
-4	120380	. WASHER, Lock, 1/4.....							12	
-5	65372	. VALVE, Hand.....							8	
-6	65167	. GAUGE, Pressure.....							1	
-7	132259	. SCREW, Mach, flg hd, 1/4-20 x 5/8.....							2	
-8	83623	. REGULATOR, Pressure.....							1	
-9	83533	. COVER, C.G.A. -346.....							1	
-10	83521	. ADAPTER, 1/4NPT x C.G.A. -346.....							1	
-11	443331	. NUT, Lock, 1/4-20.....							2	
-12	274473	. SCREW, Mach, serr fig hd, 1/4-20NC x 5/8.....							2	
-13	67919	. WASHER, Flat- SAE 1/4.....							2	
-14	83684	. PANEL, Control.....							1	

7-10

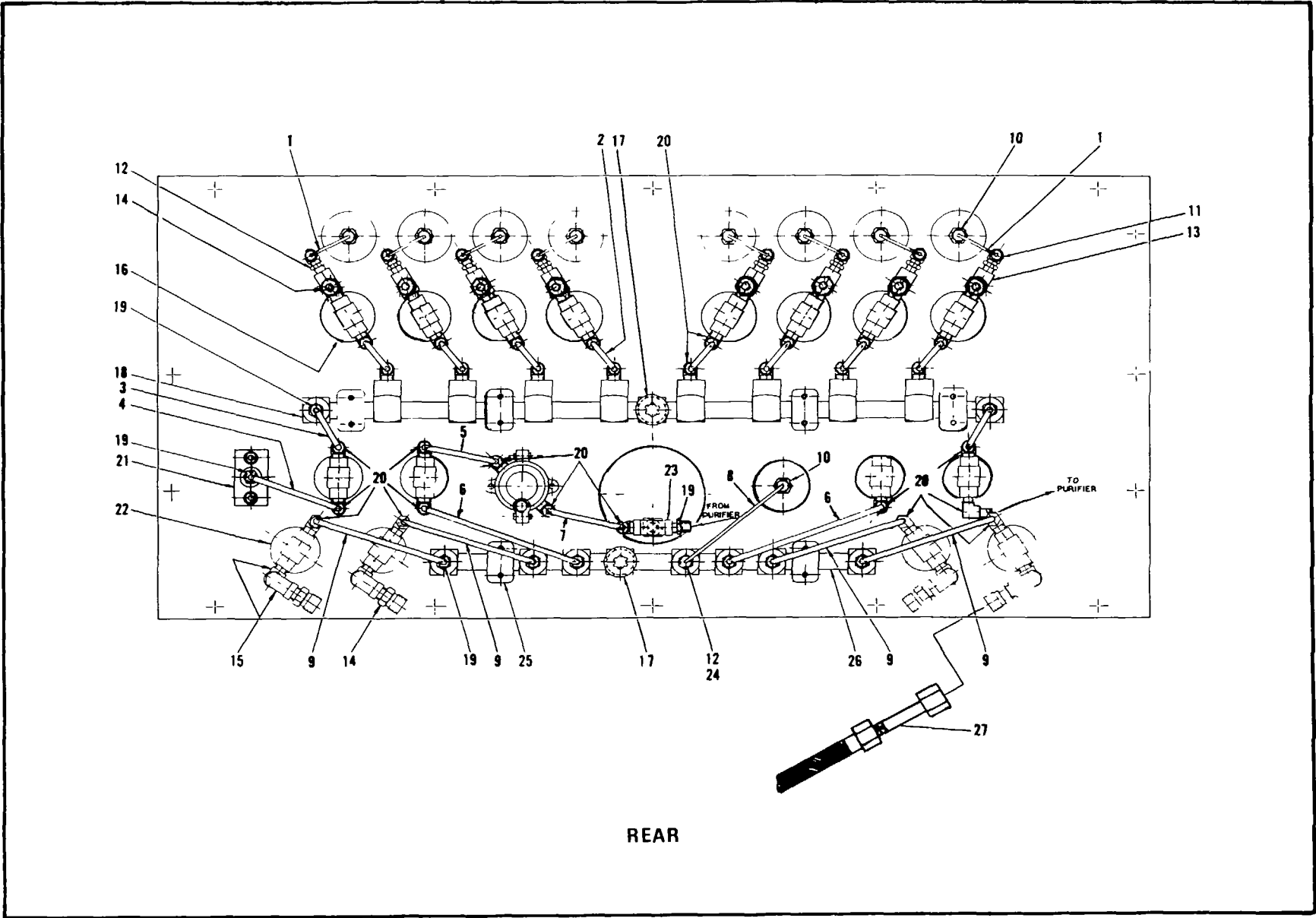

Figure 7-4. Control Panel Assembly, Air (Sheet 2 of 2).

FIGURE & INDEX NUMBER	PART NUMBER	DESCRIPTION 1 2 3 4 5 6 7	QTY PER ASSY	USABLE ON CODE
7-4-	83887	CONTROL PANEL ASSY, Air, Type 1 (Sheet 2 of 2)	REF	
-1	83525-01	. TUBE ASSY, Lever valve to gauge	8	
-2	83526-01	. TUBE ASSY, Lever valve to supply manifold	8	
-3	83526-02	. TUBE ASSY, Supply manifold to hd valve	1	
-4	83526-03	. TUBE ASSY, Air manifold to hd valve	1	
-5	83526-04	. TUBE ASSY, Hd valve to press reg.....	1	
-6	83526-06	. TUBE ASSY, Hd valve to scuba manifold	2	
-7	83526-.05	. TUBE ASSY, Press reg to press gauge	1	
-8	83525-02	. TUBE ASSY, Press gauge to scuba manifold	1	
-9	83526-07	. TUBE ASSY, Hd valve to scuba manifold	4	
-10	67955	. CONNECTOR, Female, 1/8 T x 1/8 NPT.....	8	
-11	29784	. ELBOW, 90°, male 1/8 T x 1/8 NPT	8	
-12	144035	. BUSHING, Reducer, 1/8 T x 1/4 NPT.....	9	
-13	79088	. TEE, Street, 1/4 NPT	8	
-14	83521	. OUTLET, Male, CGA-346 x 1/4NPT	12	
-15	39850	. ELBOW, Street, 1/4NPT	8	
-16	131019	. WASHER, Flat, 1"	8	
-17	28122	. VALVE, Safety, 3800 psi	2	
-18	83468	. MANIFOLD, Supply, Type I	1	
-19	28836	. CONNECTOR, Male, 1/4T x 1/4NPT.....	10	
-20	28842	. ELBOW, 90°, male, 1/4T x 1/4NPT	30	
-21	81733	. MANIFOLD, Air, panel mount,	1	
-22	131018	. WASHER, Flat, 7/8"	8	
-23	83901	. TEE, Female, 1/4NPT	1	
-24	28834	. CONNECTOR, Male, 1/8T x 1/8NPT.....	1	
-25	83969	. CLAMP, Manifold	6	
-26	83469	. MANIFOLD, Scuba, Type I.....	1	
-27	85254	. HOSE AND FILLER (AIR) VALVE, Sub-ass'y	4	

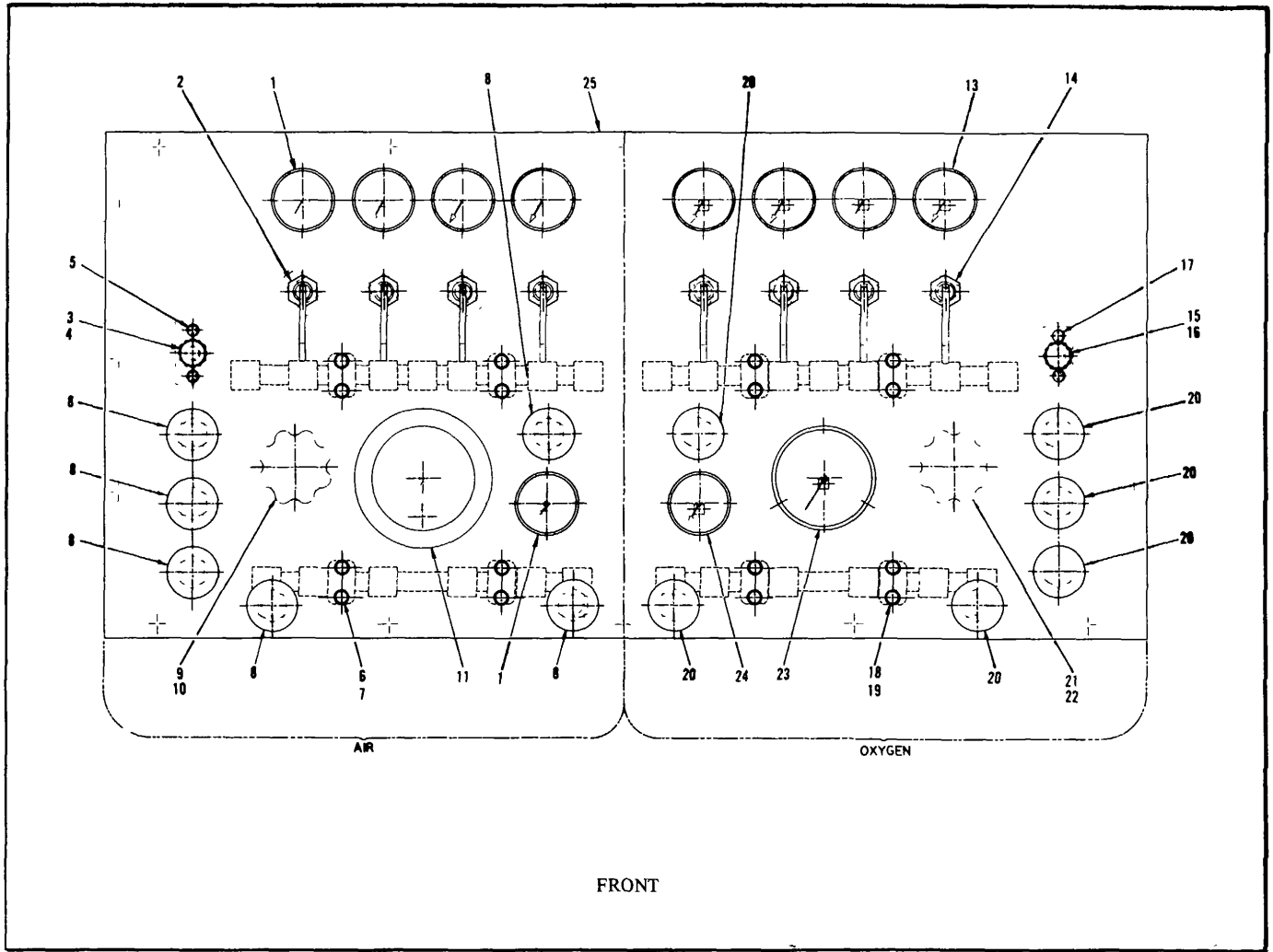

Figure 7-5. Control Panel Assembly, Air/Oxygen, Type II (Sheet 1 of 2)

FIGURE & INDEX NUMBER	PART NUMBER	DESCRIPTION							QTY PER ASSY	USABLE ON CODE
		1	2	3	4	5	6	7		
83888		CONTROL PANEL ASSY, Type II, (Air/Oxygen).....							REF	
		AIR PANEL SECTION								
-1	65165	· GAUGE, Pressure, air							5	
-2	83382	· VALVE, Cam-lever							4	
-3	83533	· COVER (C.G.A.-346)							1	
-4	83521	· ADAPTOR, 1/4NPT x C,G A.-346							1	
-5	274473	· SCREW, Mach. serr, hd, 1/4-20 x 5/8"							2	
-6	121940	· SCREW, Hex hd, 1/4-20 x 1-3/4							8	
-7	120380	· WASHER, Lock, 1/4"							8	
-8	65372	· VALVE, Hand, air ,							6	
-9	132259	· SCREW, Mach, fil hd, 1/4-20 x 5/8							2	
-10	83623	· REGULATOR, Pressure, air.....							1	
-11	65167	· GAUGE, Pressure, air regulator.....							1	
-12	Deleted									
		OXYGEN PANEL SECTION								
,13	3390	· GAUGE, Pressure, oxygen							5	
-14	85347	· VALVE, Cam - lever (oxygen)							4	
-15	83557	· COVER (C G A,-540)							1	
-16	83556	· ADAPTOR, 1/4NPT x C G.A-540) (connector).....							1	
-17	274473	· SCREW, Mach, serr flg hd, 1/4-20 x 5/8							2	
-18	121940	· SCREW, Hex hd, 1/4-20 x 1-3/4"							8	
-19	120380	· WASHER, Lock, 1/4"							8	
-20	83383	· VALVE, Hand, oxygen....							6	
-21	132259	· SCREW, Mach, fil hd, 1/4-20 x 5/8"							2	
-22	83623	· REGULATOR, Pressure, Oxygen							1	
-23	83539	· GAUGE, Pressure, oxygen, regulator							1	
-24	83390	· GAUGE, Pressure, manifold oxygen.....							1	
-25	83685	· PANEL, Control, air/oxygen							1	

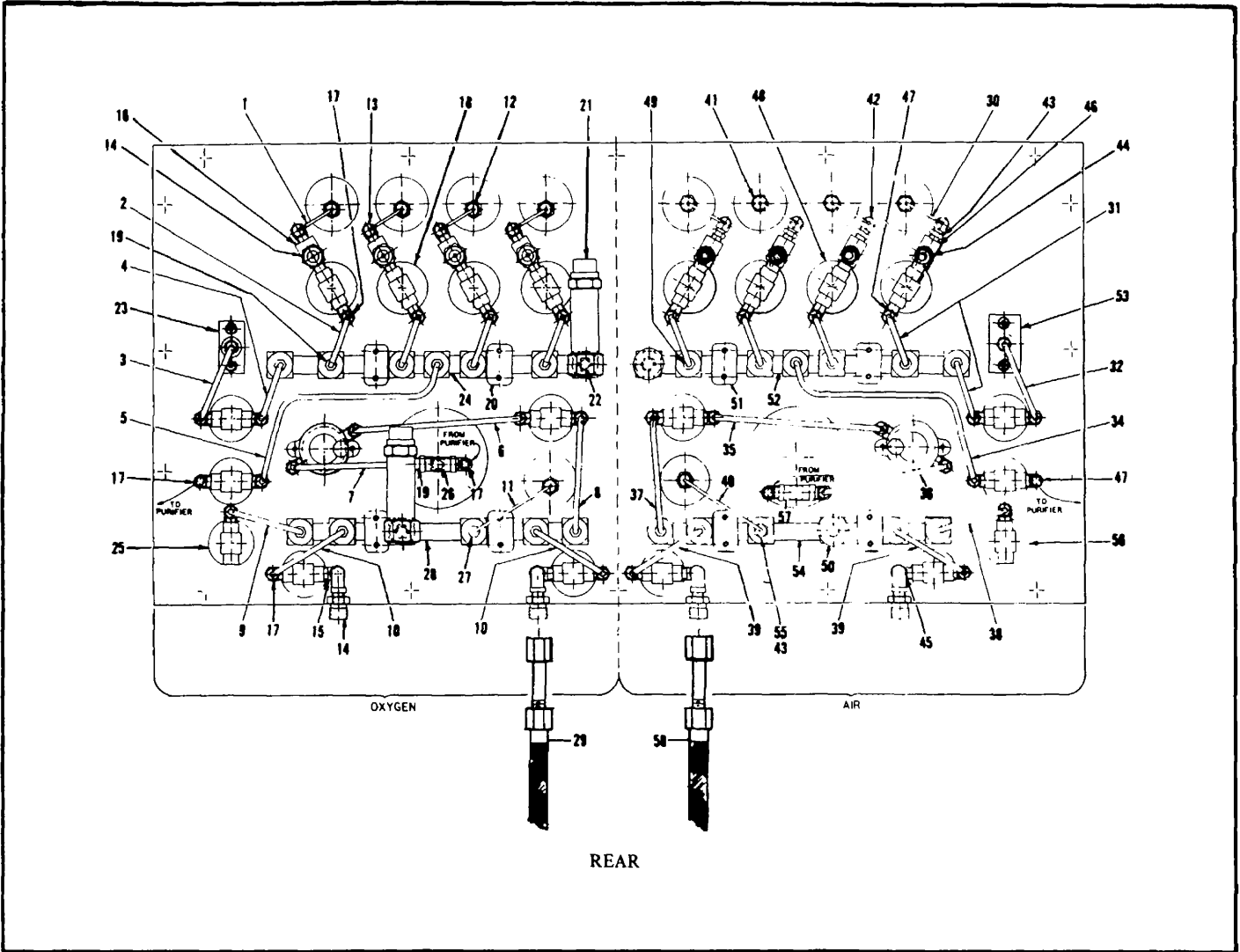

Figure 7-5. Control Panel Assembly, Air Oxygen, Type II (Sheet 2 of 2)

FIGURE & INDEX NUMBER	PART NUMBER	DESCRIPTION 1 2 3 4 5 6 7	QTY PER ASSY	USABLE ON CODE
83888		CONTROL PANEL ASSY, Type II (Air/Oxygen)	REF	
		OXYGEN PANEL (REAR)		
-1	83525-06	. TUBE ASSY, 1/8" Dia, lever valve to press & gauge	4	
-2	83534-01	. TUBE ASSY, 5116 Dia, lever valve to supply manifold, Type II	4	
-3	83534-03	. TUBE ASSY, Panel manifold to hd valve.	1	
-4	83534-02	. TUBE ASSY, Supply manifold to hd valve	1	
-5	83534-04	. TUBE ASSY, Supply manifold to hd valve	1	
-6	83534-06	. TUBE ASSY, Hd vol to press & reg.....	1	
-7	83534-05	. TUBE ASSY, Press reg to press. gauge... ..	1	
-8	83534.07	. TUBE ASSY, Supply manifold to hd valve.....	1	
-9	83534-08	. TUBE ASSY, Scuba manifold to hd valve	1	
-10	83534.09	. TUBE ASSY, Scuba manifold to hd valve	2	
-11	83525-05	. TUBE ASSY, Press. gauge to scuba manifold ...	1	
-12	84509	. CONNECTOR, Female, 1/8 Tx 1/4 NPT	5	
-13	83904	. ELBOW, Male, 900, 1/8 T x 1/4 NPT.....	4	
-14	83556	. OUTLET, Male CGA-540 x 1/4 NPT.....	6	
-15	83553	. ELBOW, Street, 900 1/4 NPT.....	4	
-16	83903	. TEE, Street, 1/4 NPT.....	4	
-17	83899	. ELBOW, Male 900, 5/16 T x 1/4 NPT.....	17	
-18	131019	. WASHER, Flat 1"	4	
-19	83598	. CONNECTOR, Male 5/16 Tx 1/4 NPT.....	11	
-20	83969	. CLAMP, Manifold	4	
-21	83333	. VALVE, Safety, 3800 psi	2	
-22	83562	. CONNECTOR, 1/4 x 1/4 NPT	2	
-23	83391	. MANIFOLD, Input, panel mounted	1	
-24	83470	. MANIFOLD, Supply - Type II.....	1	
-25	131018	. WASHER, Flat 7/8".....	6	
-26	83901	. TEE, Female, 1/4 NPT	1	
-27	83906	. CONNECTOR, Male, 1/8 Tx 1/4 NPT.....	1	
-28	83471	. MANIFOLD, Scuba, Type II.....	1	
-29	85255	. HOSE AND FILLER (OXYGEN) VALVE, Sub-assy	2	
		AIR PANEL (REAR)		
-30	83525-01	. TUBEASSY, Lever vol to press. Gauge	4	
-31	83526-08	. TUBE ASSY, Lever vol to supply manifold.. ..	5	
-32	83526-09	. TUBE ASSY, Panel manifold to hd valve	1	
-33	Deleted			
-34	85261	. TUBE ASSY, Supply manifold to hd valve	1	
-35	83526-11	. TUBE ASSY, Press reg to hd valve.....	1	
-36	83526-10	. TUBE ASSY, Res. reg to pres. Gauge	1	
-37	83526-12	. TUBE ASSY, Hd valve to scuba manifold	1	
-38	83526-13	. TUBE ASSY, Scuba manifold to drain valve.....	1	
-39	83526-14	. TUBE ASSY, Hd valve to scuba manifold.....	2	
-40	83525-03	. TUBE ASSY, Scuba manifold to press gauge.....	1	
-41	67955	. CONNECTOR, Female 1/8 T x 1/8 NPT	5	
-42	29784	. ELBOW, Male 900, 1/8 Tx 1/8 NPT.....	4	
-43	144035	. BUSHING, Reducer 1/4 NPT x 1/8 NPT.	5	
-44	83521	. OUTLET, Male, CGA-346 x 1/4 NPT.....	6	
-45	39850	. ELBOW, Street 900, 1/4NPT.....	4	
-46	79088	. TEE, Street 1/4 NPT.....	4	
47	28842	. ELBOW, Male 900, 1/4Tx 1/4NPT.....	17	
48	131019	. WASHER, Flat, 1"	4	
-49	28836	. CONNECTOR, Male 1/4 T x 1/4 NPT.....	11	
-50	28122	. VALVE, Safety, 3800 psi	2	

FIGURE & INDEX NUMBER	PART NUMBER	DESCRIPTION 1 2 3 4 5 6 7	QTY PER ASSY	USABLE ON CODE
-51	83969	· CLAMP, Manifold	4	
-52	83470	· MANIFOLD, Supply, Type II	1	
-53	81733.	· MANIFOLD, Panel mounted	1	
-54	83471	· MANIFOLD, Scuba, Type II.....	1	
-55	28834	· CONNECTOR, Male 1/8 T x 1/8 NPT.....	1	
-56	131018	· WASHER, Flat 7/8"	6	
-57	65609	· TEE, Female, 1/4 NPT	1	
-58	85254	· HOSE AND FILLER (AIR) VALVE, Sub assy.....	2	
7-17				

CHAPTER III

**COMMERCIAL TRAILER
MODEL CT- 1
PART NUMBER 86169 (16004)**

USED WITH

**MANIFOLD SERVICING UNIT, CASCADE
COMPRESSED GAS, AIR
TRAILER MOUNTED (COMMERCIAL), TYPE 1
PART NUMBER 83208 (16004)**

**MANIFOLD SERVICING UNIT, DUAL
AIR/OXYGEN
TRAILER MOUNTED (COMMERCIAL), TYPE II
PART NUMBER 83209 (16004)**

WARNING

1. Do not perform maintenance or disconnect any hose or pressurized line before draining pressure from lines.
2. Make sure tow bar jack is down and properly pinned before disengaging trailer unit from towing vehicle.
3. Make sure all wheel lugs are tight before trailer is moved or put in use.

a/(b blank)

CHAPTER III

TABLE OF CONTENTS

Section/ Para	Page
I. INTRODUCTION AND GENERAL INFORMATION.....	1-1
1-1 Introduction.....	1-1
1-2 General Information	1-1
1-3 Description	1-1
1-4 Consumable Material	1-1
II. SPECIAL TOOLS AND TEST EQUIPMENT.....	2-1
2-1 General.....	2-1
III. PREPARATION FOR USE AND SHIPMENT	3-1
3-1 General.....	3-1
3-2 Preparation for Use	3-1
3-3 Preparation for Storage or Shipment	3-1
IV. OPERATION INSTRUCTIONS	4-1
4-1 General.....	4-1
4-2 Operation.....	4-1
4-3 Operation Instructions	4-1
V. MAINTENANCE INSTRUCTIONS	5-1
5-1 General.....	5-1
5-2 Inspection and Preventative Maintenance	5-1
5-3 Lubrications Instructions	5-1
5-4 Troubleshooting	5-1
VI. REPAIR INSTRUCTIONS	6-1
6-1 Repair.....	6-1
6-2 Preliminary Procedures.....	6-1
6-3 Disassembly of Major Components	6-3
6-4 Air Over Hydraulic Brake System Tubing Group.....	6-3
6-5 Air Filter	6-5
6-6 Relay Valve	6-6
6-7 Reservoir	6-6
6-8 Automatic Drain Valve.....	6-6
6-9 Power Cluster.....	6-8
6-10 Cable Assembly 24 Volt	6-8
6-11 Cable Assembly 12 Volt	6-9
6-12 Wiring Harness, Trailer	6-10
6-13 Electrical Box	6-11
6-14 Electrical Box (Removal from loaded trailer).....	6-12
6-15 Combination Lights (stop and turn signal).....	6-13
6-16 Marker/Clearance Lights	6-13
6-17 Axle Assembly.....	6-14
6-18 Parking Brake Lever and Cross-shaft Assembly	6-17
6-19 Brake Assembly	6-18
6-20 Test	6-18

CHAPTER III

TABLE OF CONTENTS

Section/ Para		Page
VII.	IILLUSTRATED PARTS BREAKDOWN	7-1
7-1	General.....	7-1
7-2	Maintenance Parts List	7-1

LIST OF ILLUSTRATIONS

Figure		Page
7-1	Commercial Trailer Assembly, Model CT-1	7-2
7-2	Hose and Tubing Assemblies.....	7-5
7-3	Wiring Diagram, Commercial Trailer, Model CT-1	7-7
7-4	Cable Assembly, 24 Volt	7-9
7-5	Cable Assembly, 12 Volt	7-11
7-6	Wiring Diagram, Trailer Chassis	7-13
7-7	Electrical Box Assembly	7-15
7-8	Air Filter	7-17
7-9	Axle Assembly.....	7-18
7-10	Brake Assembly	7-20
7-11	Drain Valve.....	7-22
7-12	Parking Brake Assembly	7-24
7-13	Electrical System Layout.....	7-25

LIST OF TABLES

Number		Page
2-1	Table of Leading Particulars.....	2-1
5-1	Troubleshooting.....	5-2
VIII.	MANUFACTURE'S DATA	
	Power Cluster.....	8-1
	RE-6 Relay Valve	8-5

CHAPTER III

SECTION I.

1-1. INTRODUCTION This section contains operation and maintenance instructions with illustrated parts breakdown for the Davey 5000 lb gross axle weight Commercial Trailer, Model CT-1

1-2. GENERAL INFORMATION The CT-1, Commercial Trailer is utilized in this application as the mounting platform for the Servicing Units, Type I (Air) and Type II (Air/Oxygen).

1-3. DESCRIPTION The CT-1 Commercial Trailer, consists of the electrical system, air over hydraulic brake system, the axle assembly and the welded frame assembly

1-4. CONSUMABLE MATERIALS Consumable materials utilized on or in the CT-1 Commercial Trailer are as follows:
(See lubrication instructions Section V

Brake Handle and Pillow Block	SAE 30 Oil (2 Places)
Trailer Wheel Hubs	SAE 90 Oil (2 Places)
Master Cylinder (Power Cluster)	Commercial Grade Brake Fluid

SECTION II.

SPECIAL TOOLS AND TEST EQUIPMENT

2-1. GENERAL. No Special Tools or Test Equipment are required for the inspection, repair or testing of the Commercial Trailer.

TABLE 2-1. LEADING PARTICULARS

Item	Particulars
Commercial Trailer, Model CT-1	MIL-C-52437 B (ME)
Operating Temperature Range	-40 F to 120 F
Capacity	5000 lb Gross Axle Weight
Trailer Assy. Weight	10931bs. (496 kg)
Over-all Length	145 in. (3683 mm)
Over-all Height	32 In. (812.8 mgs)
Over-all Width	78 In (1981.2 mm)
Shipping Cubage	209 ft. (5.9 M)
Highway Speed	55 MPH
Off Road Speed	25 MPH
Tire Pressure	35 PSIG

1-1/2-1/(2-2 blank)

SECTION III.

PREPARATION FOR USE AND SHIPMENT

3-1. Preparation For Use: To prepare the CT-1 Commercial Trailer for use, proceed as follows:

WARNING

Use extreme care If "manhandling" trailer is contemplated, the tow eye end of the trailer is heavy

- a. Position, set and lock towbar jack
- b. Position and set parking brakes.
- c. To deprocess the CT-1 Commercial Trailer, refer to applicable DA Forms 2256, Preservation and Depreservation guide for Vehicles and Equipment.

CAUTION

Pay particular attention to wet hub area, make certain hubs are not leaking.

- d. Inspect trailer unit for damage to the air/hydraulic system, lose fittings or lose or missing hardware. Replace damaged items as required.
- e. Inspect trailer unit electrical system for damage to, or malfunction of unit electrical system, loose fittings, broken wire, abrasions, burned out light bulbs or inoperable lights. Repair or replace damage items as required.

SECTION IV.

OPERATING INSTRUCTIONS

4-1. GENERAL: The CT-1 Commercial Trailer is designed to be used with either military or commercial hauling units within the 2 to 5 ton weight category

4-2. OPERATION The CT-1 Commercial Trailer was designed to provide the user a heavy duty trailer unit within the 5000 lb maximum gross weight axle range The trailer unit frame is of an all welded steel construction which incorporates the capabilities of a dual 12v and 24v lighting system and a air/hydraulic brake system which is serviced by service air and emergency air input furnished by the tow vehicles. Support to the towbar end is furnished by movable, sidewind, 3000 lb capacity towbar jack which has a self aligning mud pad.

4-3. OPERATING INSTRUCTIONS:

- a. Prior To Operation- Prior to using the CT-1 Commercial Trailer, perform the following procedure.
 - (1) Performs all inspections checks, and services required. Refer to Section V, Paragraph 5-2.
- b. OPERATION:

WARNING

The Towbar end of the Trailer is heavy, extreme care shall be used when attaching trailer to towing vehicle.

- (1). Attach trailer to towing vehicle.

- (2). Attach safety chains to towing vehicle.
- (3). Attach Service air hose gladhand to Service air connector on towing vehicle (if available).
- (4). Attach emergency air hose gladhand to emergency air connector on towing vehicle (if available).
- (5). Attach applicable (12V or 24V) electrical connector to female electrical connector on towing vehicle (if available).
- (6). Remove safety pin from towbar jack and swivel Jack upwards to the horizontal position, and replace jack safety pin.
- (7). Activate the towing vehicles air brake supply systems so that a functional check of the trailers air/hydraulic brake systems can be made.
- (8). In addition to the brake check, activate the towing vehicles light system, so that a function check can be accomplished on the trailer electrical/light system.
- (9). After checking brake and electrical systems, trailer is ready for use.

4-4. AFTER OPERATIONS: After operations the towing vehicles electrical and air systems should be shut off and disconnected from the trailer unit. Proceed to step a. to secure trailer for short term parking.

a. Air Reservoir. To bleed the air from the brake system, emergency air reservoir, open air reservoir bleed valve. Close the valve after air reservoir has emptied of all pressure.

(1) The mechanical drain valve is located on the bottom end of the air reservoir facing the road side. The air reservoir is mounted on the front side of the second crossmember (8, Figure 7-6).

SECTION V.

MAINTENANCE INSTRUCTIONS

5-1. GENERAL This section contains those inspection and preventive maintenance actions that are required for the CT-1, Commercial Trailer Unit.

5-2. INSPECTION AND PREVENTIVE MAINTENANCE.

- a. Check and maintain tire pressure @ 35psi before each use and on a monthly basis
- b. Check oil level In wheel hubs before each use or daily when in use Add oil as required
- c. Check brake fluids level in power cluster (master cylinder) - Before each use
- d. Check brake system air hoses for tears, breaks or cuts. - Before each use - daily when used
- e. Check brake line tubing and fittings for cracks and leakage. - Before each use
- f. Check component mounting for tightness - Before each use, - monthly, more often if rough terrain is traveled
- g. Check lights - before each use, daily when in use
- h. Check 12V and 24V cable assemblies - before each use.
- i. Check Towbar jack for working order, check safety pin for damage-- before each use, daily when in use.
- j. Welded frame assembly- visually check frame for cracks, tears, broken welds Repair as necessary-- Every six months, or before each use.

5-3. LUBRICATION INSTRUCTIONS: The following lubrication instructions shall be followed on the CT-1 Commercial Trailer.

- a. Parking Brake Lever And Cross -shaft Assembly. Oil pillow blocks with 30w engine oil - monthly.
- b. Wet Hubs. Check daily when In use, fill as needed, check monthly, and rotate wheels several times for lubrication proposes. Add SAE 90 oil as required. Fill to mark on caps
(1) Change oil in hubs at least once each year.
- c. Power Cluster (Master Cylinder) - Check before each use, add commercial grade brake fluid as required.

5-4. TROUBLESHOOTING. (See Table 5-1) This table will aid maintenance personnel by indicating possible problem areas while operating the trailer unit.

TABLE 5-1. TROUBLESHOOTING

TROUBLE	PROBABLE CAUSE	REMEDY
1. Pressure loss in brake system	<ol style="list-style-type: none"> 1. Leaking fittings or loose connection 2. Cracked tube 3. Valve leaking 4. Valve slightly open on Air reservoir. 	<ol style="list-style-type: none"> 1. Check tube and fittings for tightness. Replace of damaged fittings. 2. Replace damaged tubes. 3. Check drain valve and relay valve. Replace damaged valves. 4. Close drain valve.
2. Faulty lamp	<ol style="list-style-type: none"> 1. Lamp bulb burned out or damaged. 2. Bad ground 3. Corroded socket. 4. Faulty lamp connector. 5. Break in wiring circuit 6. Circuit breaker malfunction. 7. Corroded commercial or military connector 8. Malfunctioning towing vehicle electrical system. 9. Electrical box malfunctions. 	<ol style="list-style-type: none"> 1. Replace bulb. 2. Reground lamp. 3. Clean or replace socket as necessary. 4. Reconnect clean or replace as necessary. 5. Repair wire. 6. Replace circuit breaker. 7. Clean or replace as required. 8. Refer to applicable vehicle T.O. or maintenance manual as required. Possible 12VDC Military system could be present. 9. Perform continuity checks on applicable resistors , diodes and circuit breakers. Replace as required.
3. Oil leak, wet hubs	<ol style="list-style-type: none"> 1. Leaking rear oil seal 	<ol style="list-style-type: none"> 1. Replace oil seal.
4. Loose/damaged trailer frame members	<ol style="list-style-type: none"> 1. Cracks , tears, weld breaks trailer Chassis. 	<ol style="list-style-type: none"> 1. Repair as required.

SECTION VI.

REPAIR SECTION

6-1. REPAIR. The following paragraphs contains instructions for the CT-1 Commercial Trailer. These instructions will enable maintenance personnel to repair or replace defective parts, which allows the Trailer Unit to meet new equipment standards Instructions are included for the disassembly, cleaning, Inspection, repair or replacement and assembly of components and parts, to form a complete CT-1 Commercial Trailer Unit. General cleaning, inspection, and repair or replacement is as follows:

NOTE

After performing any repair on the trailer unit, perform a check on the effected system to insure proper operation.

6-2. PRELIMINARY PROCEDURE In general It is not necessary to completely disassemble the trailer unit as illustrated In Figure 7-1. Operational checkout and troubleshooting will indicate the required degree of disassembly necessary and assemblies which require repair or replacement. Prior to complete disassembly of the trailer unit, the following step-by-step procedures shall be completed as follows

- a. Position trailer unit at the maintenance site, and pin towbar jack and set trailer unit handbrake.

WARNING

Never attempt to disassemble any part of the brake system without first having relieved all air pressure from the brake system.

WARNING

Provide adequate ventilation when using cleaning solvent (Federal Specifications P-D-680, Type II). Avoid prolonged breathing of vapors and minimize skin contact.

CAUTION

Solvents conforming to Federal Specification P-D-680, Type II shall not be used to clean paint coatings, plastics, and rubber. Disposal of solvents conforming to Federal Specification P-D-680,, Type II shall be accomplished in accordand with local state water pollution control laws. Consult local bioenvironmental engineer for guidance. In no instance should these solvents be allowed to contaminate streams or lakes They may be disposed of by evaporation or burning under supervision.

NOTE

Do not allow parts to remain in cleaning solvent for extended periods of time or rust spots may form If parts are not to be inspected immediately after cleaning, dip them in engine oil per Military Specification MIL-L-2104C or equivalent. Do not immerse electrical parts In cleaning solvent.

b. Cleaning.

- (1). Clean all unpainted metal parts using cleaning solvent that is in accordance with Federal Specification P-D-680, Type II, or equivalent. Wipe nonmetallic parts with a clean, lint-free cloth moistened in detergent and water and air dry.
- (2). Clean all painted surfaces by spraying with hot water and detergent solution per Federal Specification P-D-220. Parts that will be repainted may be cleaned with steam. After cleaning, refinish affected painted areas where required.

CAUTION

Do not use steam or water to clean any electrical components or assemblies such as electrical gauges, switches and solenoids.

- (3). Clean electrical components with trichloroethane, per Federal Specification O-T-620 or equivalent.

WARNING

Proper precaution must be exercised to protect personnel. Stand clear of all tubing openings. After cleaning, drain tubes, and dry with low pressure compressed air (30 psig maximum (206 KPa).

- (4). Clean outside and inside surfaces of the steel tubing and hose assemblies with compressed air, pressurized hot water and detergent or steam.

c. Inspection. In general, inspect as follows:

- (1). Inspect for visible wear, damage, distortion, cracks, breaks, and corrosion Replace all o-rings, gaskets and seals.
- (2). Inspect threaded parts and hardware for stripped threads, cross-threading and for nicks and burrs.
- (3). Inspect hoses, flex hoses, and tubing for evidence of leaks, cracks, pinching, chaffing conditions, damaged connecting nuts, and similar defects.
- (4). Inspect painted surfaces for chipping, peeling or discolored paint.

d. Repair or Replacement. For the most part, repair of this equipment will be made by replacement of worn or damaged parts. Detailed repair and replacement procedures for specific parts are found in the following subassembly paragraphs.

- (1) Minor nicks, scoring or scratches on non-critical surfaces may be smoothed with crocus cloth per Federal Specification P-C-458.
- (2). Repair or replace steel tube assemblies attachment fittings, proceed as follows:

NOTE

Before attempting to repair tube fittings. Make certain stainless steel tubing is of sufficient length to fit after cutting off end containing damaged fittings. If not long enough, replace whole tube assembly.

- (a). Cut off tubing just beyond damaged fitting
- (b). Slide tubing nut and then the sleeve onto the tubing, refer to Figure 6-1. make sure that end of tubing is free of any burrs and is reasonably square.
- (c). Insert the end of the tubing into mating fitting, see Figure 6-2. Make certain that tubing end is bottomed on fitting shoulder. Apply a good grade of lubricant on end of tubing.

- (d). Turn tubing nut slowly with wrench while turning tubing with other hand. When the sleeve grips the tubing, that is when the tubing can no longer be turned by hand, stop turning nut and note position of wrench. This is termed the ring grip point.
- (e). Then, tighten the nut an additional one turn past the ring grip point.
- (f). Unscrew nut and remove the tubing from the mating fitting, or presetting tool. Inspect the preset as described in Figure 6-1.
- (g). When installing a preset tubing assembly, lubricate with clean oil.

CAUTION

At installation of tubing assemblies, do not overtighten tubing nuts.

- (h). Insert tubing assembly into fitting and tighten nut until a sharp rise in torque is felt. Starting at position of sharp torque rise, tighten the nut 1/4 additional turn to complete the assembly.

NOTE

At the point where the torque starts to rise, the sleeve and tubing are just touching the seat. An additional 1/4 turn produces a seal with the fitting and restores the bow to the sleeve.

- (3). Replace damaged or defective fittings.

6-3. **DISASSEMBLY OF MAJOR COMPONENTS:** Limit disassembly of major components to the extent necessary to repair or replace a given assembly. All major components are covered in the following paragraphs. Refer to Figure 7-1 for major components.

NOTE

Unless otherwise specified, all figures referenced in this section will be found in Section VII, Illustrated Parts Breakdown.

NOTE

Remove tubing and hose assembly as needed in the disassembly process. Tag tube or hose assembly for reassembly purposes.

WARNING

Do not attempt to disassemble any part of the brake air system without first being sure that all pressure has been relieved from the system. (See Figure 7-1 and 7-2).

6-4. **AIR OVER HYDRAULIC BRAKE SYSTEM (TUBING GROUP):** See Figure 7-2. The following paragraphs contain disassembly, cleaning, inspection, repair or replacement and assembly instructions for the air over hydraulic brake system.

- a. **Disassembly-** Disassemble the air over hydraulic brake system only to the extent necessary - to repair or replace a defective part or parts.
 - (1). Unscrew and remove the service air hose assembly (1, Figure 7-2) at the towbar mounting post. Do not disassemble the service air hose assembly unless necessary.
 - (2). Unscrew tube assy. (8, Figure 7-2) at the towbar mounting post. Disengage from connector (7) Remove adaptor (2). Unscrew and remove bulkhead coupling (3) from

air hose mounting part. Straight connector (7) need not be removed from coupling (3) unless damaged. Do not remove Service tag (5) unless It needs to be replaced.

- (3). Repeat (1) and (2) above for the emergency air hose assembly (, Figure 7-2).
- (4). Remove screws from tubing clips securing tube assemblies (8 and 9 Figure 7-2). Tubing clips need not be removed from tube assemblies unless it is necessary.
- (5). Unscrew and remove tube assy. (8, 9) from air filter (6, Figure 7-1). Tag for reassembly purposes.
- (6). Unscrew and remove tube assembly (10, Figure 7-2). Tag air filter to RE-6 Valve, for reassembly purposes.
- (7). Remove tubing clip nuts and screws which are located on the top of the air resevoir mounting plate. Unscrew and remove tube assy (11). Tag for reassembly purposes.
- (8). Unscrew and remove tube assembly)12, Figure 7-2) between the relay valve (7, Figure 7-1) and air reservoir. (8). Tag for reassembly purposes.
- (9). Remove screws from tubing clips securing tube assembly (13, Figure 7-2) from the relay valve (7, Figure 7-1) to the power cluster (1). Remove tube assembly (13, Figure 7-2) Tag for reassembly purposes.
- (10). Unscrew and remove tube assembly (14) between the air reservoir (8, Figure 7-1) and drain valve (23). Tag for reassembly purposes.

NOTE

Use container to catch brake fluid as needed during disassembly of hydraulic brake line tubing.

- (11). Drain brake fluid from brake system4
 - (12). Remove screws securing tubing clips used on tube assembly (15, Figure 7-2), power cluster to the bulkhead tee. Unscrew and remove tubing assembly (15). Tag for reassembly purposes.
 - (13). Bulkhead Tee (16) and bulkhead elbows (19) do not need to be disassembled from trailer frame unless It Is necessary. Remove tube assemblies (17,18) from bulkhead Tee (16) and bulkhead elbows (19).
 - (14). Remove brake lines (24).
- b. Cleaning. Refer to paragraph 6-2.b. for general cleaning requirements.
 - c. Inspection. Refer to paragraph 6-2. c. for general Inspection requirements.
 - d. Repair Or Replacement . Refer to paragraph 6-2. d. for general repair or replacement require requirements.
 - (1). Replace all threaded parts having worn, stripped, or damaged threads.
 - (2). Replace damaged or defective tubing.
 - (3). Replace damaged or defective fittings
 - e. Assembly. To assemble the tubing lines of the air over hydraulic brake system proceed as follows (See Figure 7-2).
 - (1). Assemble brake lines (24, Figure 7-2) to wheel and bulkhead elbow (19)

- (2). Position and assemble tube assemblies (18,17) to bulkhead elbows (19) and bulkhead Tee (16). Position tubing clips and attach with mounting hardware.
- (3). Position and assemble power cluster to bulkhead tee tube assembly(15). Position tubing clips and attach with mounting hardware.
- (4). Position and assemble air reservoir to drain valve tube assembly (14) and the relay valve to power cluser tube assembly (13). Position and attach tubing clips with attaching hardware.
- (5). Position and secure the relay valve to air reservoir tube assembly (12).
- (6). Position and attach the emergency air filter to relay valve tube assembly(I 1). Position and attach tubing clips with attaching hardware.
- (7). Position and attach air filter to relay valve tube assembly (10)
- (8). Position and attach emergency air input tube assembly (9) and service air input tube assembly (8). Position tubing clips and attach with mounting hardware.
- (9). If straight connector (7) has been removed, assemble connector (7) to coupling (3), attach bulkhead coupling (3) to mounting post. Assemble adaptor (2) to bulkhead coupling (3). Assemble tube assemblies (9,8) to connector (7).
- (10). Assemble service and emergency air hoses (1) to adaptor (2) at the air hose mounting posts.

6-5. AIR FILTER (6, Figure 7-1) The following paragraphs contain disassembly, cleaning, inspection, repair or replacement and assembly instructions for the brake system air filters.

- a. Disassembly Disassemble the air filter only to the extent necessary to repair or replace a defective part or parts.

- (1). Unscrew and remove air filter (6, Figure 7-1) mounting locknuts. Remove U-bolts and air filter (6) form frame.

NOTE

Do not remove elbows from the air filters unless it is necessary for repair or replacement purposes.

- (2). Unscrew and remove cover nut (I Figure 7-8) with plug (2) and gasket (4) from filter body (8). Remove spring (5) filter element (6) and support spring (7) form filter body (8).

- b. Cleaning. Refer to paragraph 6-2. b. for general cleaning requirements.

- c. Inspection. Refer to paragraph 6-2. c. for general inspection requirements.

- d. Repair or Replacement. Refer to paragraph 6-2. d. for general repair or replacement requirements.

- e. Assembly. To assemble the air filter, proceed as follows.

- (1). Place the filter element (6, Figure 7-8), Support Spring (7) and spring (5) together and insert into air filter body (8).

- (2). If replaced, place gasket (4) in cover nut (2) and screw cover nut (2) into filter body (8).

CAUTION

Do not over tighten cover nut (2) when assembling air filter.

- (3). Tighten cover nut firmly.

6-6. RELAY VALVE (7, Figure 7-1) For information, concerning the relay valve, see the Manufacturers Data following Section VII

- a. Remove tubing assemblies (10,11,12,13, Figure 7-2) from the relay valve. Remove relay valve (7, Figure 7-1) mounting hardware. Replace tubing assemblies in the reverse order of disassembly.
- b. See manufacturers data on relay valve

6-7. AIR RESERVOIR- (8, Figure 7-1):

- a. Disassembly. To disassemble the air reservoir assembly, proceed as follows

WARNING

Before disassembly of the air tank open reservoir manual drain valve.

- (1). Disconnect tube assemblies (12,14, Figure 7-2) from the air reservoir (8, Figure 7-1). Remove air reservoir (8) mounting hardware and brackets.
- (2). The square head plug (8, Figure 7-1) need not be removed from the air reservoir. Unscrew and remove the connector, street tee, connector and drain cock.
- b. Cleaning. Refer to paragraph 6.2. b for general cleaning requirements.
- c. Inspection. Refer to paragraph 6.2.c for general inspection requirements.
- d. Repair or replacement. Refer to paragraph 6.2.d general or replacement requirements.
- e. Assembly. To assemble the air reservoir (8, Figure 7-1), proceed as follows:
 - (1). Screw the drain cock and connector into the street tee. Attach the street tee to air reservoir (8). Screw connector into air reservoir.
 - (2). Position the air reservoir (8) and air reservoir mounting brackets into the mounting plate, and attach the mounting brackets to the mounting plate using the mounting hardware (locknuts).
 - (3). Attach tube assemblies (14,12, Figure 7-2) to the air reservoir (8, Figure 7-1) and make sure that the drain cock is closed.

6-8. AUTOMATIC DRAIN VALVE: (23, Figure 7-1)

- a. Disassembly. To disassemble the automatic drain valve, proceed as follows:

WARNING

Open the tank manual drain cock before any disassembly of the air system is performed.

NOTE

The bowl (1, Figure 7-11) may be removed from the drain valve without disassembling the drain valve from the trailer frame.

- (1). Unscrew and disengage tube assembly (14, Figure 7-2) at the drain valve (23, Figure 7-1).
- (2). Unscrew and remove the drain valve mounting hardware and drain valve from trailer frame. The straight connector and square head plug do not have to be

removed from the drain valve head (11, Figure 7-11) unless replacement is necessary. Remove drain valve mounting clamp (22, Figure 7-1) from drain valve (23).

- (3). Unscrew and remove drain valve bowl (1, Figure 7-11). Unscrew and remove unit (2) from bowl (1). Remove valve (3), valve cylinder (4) and O-Ring (5) from bowl(l).

NOTE

Element (7) does not need to be in the drain valve for the valve to function properly.

- (4). Unscrew and remove stud (6) and element (if present) (7). Remove louver (8), gasket (9) and O-ring (10) from the drain valve head (11).

b. Cleaning. To clean the drain valve, proceed as follows.

- (1) Clean all parts with soap and warm water.

- (2) Air dry parts, blow out passages in valve head, (11) with low pressure clear dry compressed air.

c. Inspection. Refer to paragraph 6-2. c. for general inspection requirements.

d. Repair or Replacement Refer to paragraph 6-2.d general repair or replacement rerequisites

e. Assembly. To assemble the drain valve assembly, proceed as follows-

- (1). Place element (7, Figure 7-11) (if present) on stud (6), louver (8) and gasket (9) onto stud (6).

- (2). Screw stud (6) into drain valve head (11).

- (3). Place Oring (5) onto valve cylinder (4). Insert valve cylinder into bowl (1), secure to bowl with connector (2). Tighten connector nut (2) to 5 to 8 lbs. in.

NOTE

During assembly, make sure that the valve (3) lip is turned down when valve is inserted into bowl.

- (4). Insert valve (3) into bowl (1). Insure that the lip in the valve is turned down.

CAUTION

Do not scratch bowl inside surface when turning lip down.

(5). Place o-ring (10) on bowl(1). Screw bowl to valve head (11). Tighten bowl to 5 to 10 lbs inch.

f. Assembly. Assemble the drain valve to the trailer frame as follows:

(1). Place drain valve (23, Figure 7-1) Into mounting clamp (22), and using mounting hardware attach drain valve (23) and clamp (22) to the trailer frame. (See Figure 7-1 for mounting locations).

(2). Attach tube assembly (14, Figure 7-2) to drain valve (23, Figure 7-1).

6-9. POWER CLUSTER (MASTER CYLINDER) (See 1, Figure 7-1). For information concerning the power cluster, see the attached manufactures data following Section VIL

a. Disassembly. Disassemble the power cluster only to the extent necessary to repair or replace a detective part or parts.

WARNING

Before working on the Air Hydraulic Brake System make sure Hydraulic Brake System has all air drained from the System.

NOTE

Drain brake fluid from power cluster before removing from the trailer frame mount.

(1). Unscrew and disengage tube assemblies (13, 15, Figure 7-2) from the power cluster (1, Figure 7-1).

(2). Remove mounting units and screws securing the power cluster (1) to the trailer frame.

(3). See Manufacturers Data, following Section VII, for additional information.

b. Assembly. Assemble the power cluster to the trailer frame as follows.

(1). Position the Power Cluster on its mounting bracket and using appropriate mounting hardware, attach the power cluster to the trailer frame.

(2). Position and attach tube assemblies (15, 13, Figure 7-2) to the power cluster. Refill power cluster with an acceptable commercial grade brake fluid. Bleed and adjust brake system as necessary.

6-10. CABLE ASSEMBLY 24 VOLT (See Figure 7-4) The following paragraphs contains disassembly, cleaning, inspection, repair or replacement and assembly procedures for the cable assembly, 24V.

a. Disassembly. Disassemble the 24V. cable assembly only to the point necessary to repair or replace a defective part or parts.

(1). Unscrew and remove screw (9 Figure 7-3) and cable clamp (7) from cable assemblies

(2). Remove screws holding cover of electrical box (5, Figure 7-1). Remove electrical box cover.

(3). Disconnect each conductor of the military 24V. cable assembly at individual conductor terminal connection, (17, Figure 7-7), there is an electrical diagram on top of the electrical box cover for use as required.

(4). Unscrew and remove cable grip (7) that holds the 24V Cable assembly stationary at the electrical box, cable assembly junction point.

NOTE

Care shall be taken in removing cable assembly from electrical box and cord grip. So that no damage is done to the box components and cable terminal.

- (5). Remove cable assembly (17) from electrical box
 - (6). Remove cable grip (7, Figure 7-7) from the electrical box (16).
- b. Cleaning. Refer to paragraph 6-2.b for general electrical cleaning procedures.
 - c. Inspection. Refer to paragraph 6-2.c . For general electrical inspection procedures.
 - d. Repair or Replacement. Refer to paragraph 6-2.d for general replacement procedures.
 - e. Assembly. To assemble the 24V cable assembly to the trailer unit, proceed as follows.
 - (1). Assemble cable grip base (7, Figure 7-7) to 24V assembly (17) and insert cable assembly (2) into electrical box (16, Figure 7-7). Place cable grip nut (7) over cable assembly (17) terminal ends, screw to cable grip (7) and tighten so that cord grip (7) is held securely to electrical box (16).
 - (2). Attach terminal ends of cable assembly (17) to proper connections.

NOTE

Check box gasket seal. Reseal suspect areas if needed, do not replace box cover until gasket seal is dry.

- (3). Attach electrical box (16)cover to the box using cover mounting screws.
- (4). Reposition cable clamps (7, Figure 7-3) on cables and attach to tow bar using screws (9).

6-11. CABLE ASSEMBLY 12 Volt. (See Figure 7-5):The following paragraphs contain disassembly, cleaning, inspection, repair or replacement and assembly procedures for the 12 Volt cable assembly.

- a. Disassembly. Disassemble the 12V Commercial cable assembly only to the point necessary to repair or replace a defective part or parts.
 - (1). Unscrew and remove screws (9, Figure 7-3) and cable clamp (7) attaching the cable assemblies to the tow bar side.
 - (2). Remove screws holding cover of electrical box (5, Figure 7-1). Remove electrical box cover.
 - (3). Disconnect each conductor of the 12V Commercial cable assembly at the terminal connection (18, Figure 7-7). There is an electrical diagram attached to the box cover for use as required'.
 - (4). Unscrew and remove cable grip (7, Figure 7-8) that holds the 12V Commercial cable assembly stationary at the electrical box.

NOTE

Care shall be taken in removing cable assembly from the electrical box and cable grip, so that no damage is done to the box components and cable terminals.

- (5). Remove cable assembly (18) from the electrical box.
- (6). Remove cable grip (7) from the electrical box (16).

- b. Cleaning. Refer to paragraph 6-2. b. for general electrical cleaning procedures
- c. Inspection. Refer to paragraph 6-2. c. for general electrical inspection procedures.
- d. Repair or Replacement. Refer to paragraph 6-2. d. for general repair or replacement procedures.
- e. Assembly. To assemble the 12V Commercial cable assembly to the trailer unit, proceed as follows:
 - (1). Assemble the cable grip (7, Figure 7:7) to the 12V cable assembly and insert cable assembly (18) into electrical box (16). Place cord grip (7) nut and washer (8) -over cable assembly (1 8), position cable assy and tighten cable grip (7) securing the cable assembly (18) to box (16).
 - (2). Attach terminal ends of cable assy (18) to proper connections.

NOTE

Check box gasket seal, Reseal suspect areas if needed, do not replace box cover until gasket seal is dry.

- (3). Attach electrical box (16) cover to the box using cover mounting screws.
- (4). Reposition cable clamps (7, Figure 7-3) on cables and attach to tow bar using screws (9).

6-12. WIRING HARNESS, TRAILER (See Figure 7-6): The following paragraphs contains disassembly, cleaning, Inspection, repair or replacement and assembly procedures for the trailer unit wiring harness.

- a. Disassembly. Disassemble the wiring harness only to the extent necessary to repair or replace a defective part or parts.
 - (1). Remove all connectors (7, Figure 7-6) from their clips (6, Figure 7-3). Disconnect the male, female connections (7, Figure 7-6). Unscrew and remove screw holding ground wires L and W to rear of front crossmember at electrical box outlet.
 - (2). Unscrew mounting screws from electrical box (16, Figure 7-7) top cover, and remove top cover. Unscrew and remove terminal block (6) wire nuts and remove wires (1 then 5 , Figure 7-6) from the terminal block (6, Figure 7-7). Replace wire nuts.
 - (3). Unscrew and carefully remove cable grip (7) hold down nut and washer (8). Remove trailer wiring harness (Figure 7-6) and cord grip (7, Figure 7-7) base from electrical box (1 6). Remove cable grip(7) base from wiring harness (Figure 7-6).

NOTE

If removed, wiring harness should be removed from front to rear.

- (4). Make sure that the wiring harness is free and not connected at any location. Feed loom covered wiring harness through each section of grommeted cross rails one at a time.
- (5). If the pieces of grommet (8, Figure 7-3) are moved out of position, reposition after wiring harness has been removed.

NOTE

Prior to removal of the loom from the wiring harness, make note of sealed or taped locations so that resealing or retaping may be accomplished at reassembly.

- (6). Remove loom (8, Figure 7-6) from wiring harness (Figure 7-6).
- b. Cleaning. Refer to paragraph 6-2. g. for general cleaning procedures.
- c. Inspection. Refer to paragraph 6-2. c. for general Inspection procedures.
- d. Repair or Replacement. Refer to paragraph 6-2.d. for general repair or replacement procedures.
- e. Assembly. To assemble the trailer unit wiring harness, proceed as follows:
 - (1). Position loom (8, Figure 7-6) and wiring harness (Figure 7-6) together, and wrap the formed loom (8) around the wiring harness.
 - (2). Seal or retape enclosed wiring harness as required.
 - (3). Make sure the pieces of grommet, (8, Figure 7-5) are in place and will not readily move.

CAUTION

Do not place an undue amount of strain on wire splice points while installing wiring harness into trailer frame.

NOTE

Installation of the loom in cased wiring harness shall be from the rear to front.

- (4). Insert the front most wiring harness connectors (7, Figure 7-6) through the rear most access holes in feed and pull the wiring harness through each set of access holes as required.
- (5). Position cable grip base (7, Figure 7-7) over wiring harness (Figure 7-6). Insert terminal ends into electrical box (16, Figure 7-7). Position washer (8), cable grip (7) over terminals. Thread ground wires L, W, Figure 7-7 through the cable grip, to the outside of the electrical box (16). Tighten the cable grip nut.
- (6). Remove nuts on terminal block (6). Position wires on perspective terminal block studs and secure with terminal block (6) nuts. Using grounding screw ground wires L and W, Figure 7-7 to the rear of the first crossmember.
- (7). Reassemble harness to light connector plugs (7, Figure 7-6) and attach each connector (7) to its respective plug clip (6, Figure 7-3). Check to see that all grommet pieces (8) are secure in the crossmember.
- (8). Check for proper light function as necessary prior to assembling electrical box cover to the electrical box.
- (9). Using cover mounting screws, assemble the electrical box (3, Figure 7-3) screws to the electrical box (3).

6-13. **ELECTRICAL BOX** (See Figure 7-7): The following paragraphs contains disassembly, cleaning, Inspection, repair; replacement and assembly procedures for the electrical box.

- a. Disassembly. Disassemble the electrical box only to the point necessary to repair or replace a defective part or parts.
 - (1) Unscrew and remove the electrical box topcover.

NOTE

Do not remove any of the screws that are positioned to act as studs for mounting the electrical box components. All "studs" are 10-32 X 1/2 pan head screws (15, Figure 7-7).

- (2). Disconnect wire end terminals from the 24V, Military cable assembly (17) ending at resistors (1,2,3), and terminal block (6) stud (Ground, White). Ground wire L need not be disconnected unless the electrical box is to be removed from the trailer unit.
- (3). Disconnect wire end terminals from, the 12V commercial cable assembly (18) wiring harness (19) at terminal block (16).
- (4). Disconnect internal component wiring as required.

NOTE

Remove only that component/s from the electrical box that must be replaced Do not remove any screw studs unless they are required to be replaced.

- (5). Remove component to be replaced by unscrewing mounting nuts, lift out component part or parts to be replaced.
- b. Cleaning. Refer to paragraph 6-2. g. for general cleaning procedures.
 - c. Inspection Refer to paragraph 6-2. c. for general inspection procedures.
 - d. Repair or Replacement. Refer to paragraph 6-2. d. for general repair or replacement procedures.
 - e. Assembly. To assemble the electrical box assembly proceed as follows.
 - (1). If a screw stud (15, Figure 7-7) was removed, replace, and use a good waterproof sealant such as, silicone base seal. Make certain the opening is sealed.
 - (2). Replace removed electrical component, using nut (14) to secure the component.
 - (3). Install internal electrical box wiring (Figure 7-7).
 - (4). Attach trailer unit wiring harness (19) to terminal block (6) and the commercial 12V cable assy to the terminal block (6) and circuit breakers (5).
 - (5). Install commercial 12V cable assembly (18) on applicable circuit breaker (5) and ground post on terminal block (6).
 - (6). Install military 24V cable assembly (17) on applicable resistors (1,2,3) and ground post on terminal block (6).
 - (7). Make certain that all mounting nuts securing the wire terminals are tight, and that spade connectors are secure.

6-14. ELECTRICAL BOX (See Figure 7-7): To disassemble the electrical box from a loaded trailer unit, proceed as follows.

NOTE

The electrical box is mounted on its mounting bracket, which is attached to mounting posts welded to the front crossmember of the trailer frame (See Figure 7-1).

- a. Disassembly.
 - (1) Unscrew and remove locknuts (5, Figure 7-1) and remove mounting bracket screws and washers from the bracket and mounting posts.
 - (2) Allow electrical box to hang on its cable harness.
 - (3) Position electrical box (5) so that the box cover screws may be removed. Remove screws and box cover.
 - (4) Refer to paragraph 6-13. above for further disassembly procedures.
- b. Assembly. Assemble electrical box (5) to the trailer frame in the reverse of paragraph 6-14. a. above.

6-15. COMBINATION LIGHTS (Service ,Stop And Turn Signal) (See 16, Figure 7-3):

- a. Disassembly. To disassemble the combination lights, proceed as follows:

NOTE

For bulb replacement, the combination lights (16, Figure 7-3) need not be removed from the trailer framework.

- (1) To remove the light bulb, remove lens spring retainer ring, lens and lift out light bulb.
- (2) Replace bulb, lens and position and replace spring retainer in its groove.
- (3) Remove light connector plug (7, Figure 7-6) from the plug clips (6, Figure 7-3), disconnect combination light (16, Figure 7-3) at the light plugs (7, Figure 7-6). Unscrew and remove light (16, Figure 7-3) mounting screws. Remove light (16) from its mounting bracket.
- b. Cleaning. Refer to paragraph 6-2. b. for general cleaning procedures.
- c. Inspection. Refer to paragraph 6-2. c. for general inspection procedures.
- d. Repair or Replacement. Refer to paragraph 6-2. d. for general repair or replacement procedures.
- e. Assembly. To assemble the combination light assembly, proceed as follows:

NOTE

Make sure combination light is mounted in the upright position, as per the instructions imprinted on the rim of the light.

- (1) Position combination light (16) in its mounting hole, secure to the high mounting bracket, using mounting screws and locknuts (16).
- (2) Assemble plug connectors (7, Figure 7-6) together, position and insert the plug connector (7) into plug clips (6, Figure 7-3).

6-16. MARKER/CLEARANCE LIGHTS (See Figure 7-3):

- a. Disassembly. To disassemble the Marker/ Clearance lights, proceed as follows:

NOTE

For bulb replacement, the marker/clearance lights are not to be removed from the trailer framework.

- (1) To remove the bulb, remove the base mounting screws from the outer light cover, unscrew and remove bulb.
- (2) Replace bulb, reposition the outer lenses cover and secure to light base with the cover mounting screws.

NOTE

Skip over step (2) if light is to be removed from the trailer unit frame.

- (3) Remove connector plug (7, Figure 7-6) from plug clip (6, Figure 7-3). Disconnect connector plug (7, Figure 7-6).
 - (4) Remove the light (14, 15) from the trailer unit framework.
- b. Cleaning. Refer to paragraph 6-2. b. for general cleaning procedures.
 - c. Inspection. Refer to paragraph 6-2. c. for general inspection procedures.
 - d. Repair or Replacement. Refer to paragraph 6-2. d. for general repair or replacement procedures.
 - e. Assembly. To assemble the marker/clearance light assembly, proceed as follows:

CAUTION

Make certain a good ground is obtained by using the internal/external tooth washer in the grounding sequence.

- (1) Position marker/clearance light (14,15 Figure 7-3) base in mounting position. Secure light base to the trailer unit frame using applicable mounting hardware.
 - (2) Connect the two (2) halves of the plug connector (7, Figure 7-6), position the connector (7) in the plug clip (6, Figure 7-3) and insert the connector into the clip.
 - (3) Position the lenses cover over the light base and secure the cover to the light base using cover mounting screws.
- 6-17. AXLE ASSEMBLY (See Figure 7-9)- The following paragraphs contain disassembly, cleaning, inspection, repair or replacement and assembly instructions for the trailer unit axle assembly.
- a. Disassembly. Disassemble the axle assembly only to the extent necessary to repair or replace a defective part or parts.

WARNING

Make certain that supports used to support the trailer unit (1,094 lbs) on the trailer unit with service unit (3640 lbs) are of sufficient construction and strength to support the weight while the axle assembly is being removed.

- (1) Using an adequate lifting device, lift trailer and place supports under trailer and place supports under trailer unit welded frame assembly.
- (2) Remove tires (14) figure 7-1) and rims (15) from axle assembly (21).

- (3) Remove shock (19, Figure 7-1) top mounting hardware, (locknut, spacers, washers and 5/8-11 bolt). Unscrew and remove bottom shock mounting hardware (1/2 locknut, washers, shock (19) from the axle shock mounting post (20, Figure 7-9).
- (4) Unscrew and remove sway bar (18, Figure 7-1) mounting hardware. Remove sway bar (18) with brackets (16) and bushing (17). Brackets (16) and bushing(17) need not be removed from the sway bar.
- (5) Unscrew and separate the parking brake pull cable (18) from the pull rods. Unscrew and remove brake cable from the axle beam mounting post.

NOTE

On the curb side wheel, the hubodometer (4) is attached to cap (3) with its mounting nut (4). Do not remove the hubodometer (4) from the cap unless it is necessary to do so.

- (6) Place a drip pan underneath wheel oil filled wet hub, unscrew and remove the socket head screws (1) from the cap ring (2). Carefully remove cap (3) and cap ring (2) as a unit, remove cap gasket (5).
- (7) Remove cotter pin (6), Spindle nut (7) and spindle washer (8). Remove outer cup (9) and outer bearing (10).

NOTE

Oil seal (12) will generally come off when the hub (11) is pulled from the axle. It is recommended that the oil seal (12) be replaced with a new seal (12) if the oil seal was removed.

- (8) Pull hub (11) with oil seal (12), inner bearing (13) and Inner cup (14) from the axle. Remove oil seal (12) Inner bearing (13) and Inner cup (14) from hub (11).
- (9) Unscrew and remove nuts (15), lockwashers (16) and bolts (17) used to mount the right and left hand brake assemblies (18) to the axle beam assembly (23).
- (10) Using suitable support, hold the axle assembly (21, Figure 7- 1) stationary. Remove mounting hardware holding the front of each spring (21, Figure 7-9) to the front spring hanger. Remove cotter pins from the rear hold down pins at each of the rear spring shackles.
- (11) Remove the rear pins from the rear Spring Shackles. Lower axle with springs, and move to a suitable work site.
- (12) Unscrew and remove locknut (19), tieplate with stud (20). springs (21) and u-bolts (22) from the axle beam assembly (23).
 - b. Cleaning. Refer to paragraph 6-2. b. for general cleaning procedures.
 - c. Inspection. Refer to paragraph 6-2.c. for general inspection procedures
 - d. Repair or Replacement. Refer to paragraph 6-2.d. for general repair or replacement procedures.
 - e. Assembly. To assemble the trailer unit axle assembly, proceed as follows

NOTE

Make certain that when springs are assembled to the axle beam assembly that the springs (21) face in the right direction (See Figure 7-9 and Figure 6-1).

- (1) Position U-bolts (22) in proper position on axle beam assembly (23). Place springs (21) on top of the axle beam assembly (23) between U-bolts (22). Position tie plate with stud (20) (stud located inside, threads to the rear) over U-bolts (22). Assemble locknuts (19) onto U-bolts (22).
- (2) Using a suitable lifting device, position axle beam assembly (23) with springs (21) underneath trailer unit frame. Place axle into position, and fit springs (21) eyes into front and rear spring hangers. Secure springs (21) to spring hangers with front and rear spring mounting hardware.

NOTE

When mounted, the pull cable on the brake assemblies (18) shall be pointing to the rear of the unit.

- (3) Position the right and left hand brake assemblies (18) on the axle beam assembly (23). Secure the brake assemblies to the axle beam using bolts (17), lockwashers (16) and nuts (15).

NOTE

Prior to assembling hub to the axle, dampen the oil seal (12) outer (I.D.) edge with oil.

- (4) Install inner cup (14), inner bearing (13), and oil seal (12) into hub.

CAUTION

Install hub with oil seal straight onto shaft. An off-center installation could damage oil seal.

- (5) Position hub (11) with inner cup (14), bearing (13) and oil seal (12) over axle beam spindle. Install hub (11) straight onto the hub shaft.

CAUTION

When spindle nut (7) is installed, tighten nut (7) only to the point that the hub (11) stops rotating freely and starts to drag. Back off the nut (7) to the first indented opening and insert cotter pin (6).

- (6) Install outer bearing (10) and outer cup (9). Install spindle washer (8), and spindle nut (7). Tighten nut until drag on the rotating hub (11) is first noticed. Back off (loosen) nut (7) slightly to the first indented opening in the nut and install cotter pin (6). Bend back ends of cotter pin (6) so that one end is bent around the nut in one direction, and the other end is bent around the nut in the reverse direction.
- (7) Install new cap gasket (5) on hub (11). Insert cap (3) into cap ring (2), using screws (1), attach cap ring (2) with cap (3) to hub (11).

- (8) If hubodometer (4) has been removed from the curbside cap (3), place cap ring (3) over cap (2), insert hubodometer (4) mounting stud through cap (2) and secure the hubodometer to cap with mounting nut (4). Attach cap ring (3) to hub (11) using mounting screws(1).
- (9) Attach parking brake cable to brake cable mounting post on the axle beam assembly (23) with the cable mounting nut. Attach the brake cable (18) to the parking brake pull rod (3, Figure 7-12), using coupler (2). Do not tighten jam nuts (1) against coupler (2) until after parking brake is adjusted.
- (10) Insert shock (19, Figure 7-1) top mounting bolt with washer through top shock grommet. Place 5/8"X long spacer over mounting bolt. Insert mounting bolt through hole in crossmember into 5/8"X 1 1/2"spacer. At the same time, align shock (19) bottom mount with mounting stud on spring plate and install shock. Secure shock (19) top mounting bolt with 5/8 locknut. Add 1/2" washer to bottom mount and secure with 1/2" locknut.
- (11) Position swaybar (18, Figure 7-1) with brackets (16) and bushings (17) and attach to the swaybar mounting brackets with securing hardware.
- (12) Position tires (14, Figure 7-1) and rims (15) over mounting studs and secure with lugnuts.
- (13) Using an adequate lifting device, remove supports from underneath trailer frame.
- (14) Position towbar jack in the down position and secure, before lifting device is removed.

6-18. PARKING BRAKE LEVER AND CROSS-SHAFT ASSEMBLY (See Figure 7-12): The following paragraphs contain disassembly, cleaning, inspection, repair or replacement and assembly Instructions for the trailer unit parking brake lever and cross-shaft.

a. Disassembly. Disassemble the parking brake lever and cross-shaft assembly only to the extent necessary to repair or replace a defective part or parts.

CAUTION

Make certain that the towbar jack assembly is pinned and in a stable condition, and that the trailer wheels are chocked.

- (1) Release parking brake lever (25, Figure 7-1) to the off position. Unscrew jam nuts (1, Figure 7-12) from coupler (2)
- (2) Unscrew and remove parking brake cable (18, Figure 7-9) from coupler (2, Figure 7-12).

CAUTION

When mounting hardware is removed from the parking brake and cross-shaft assembly (7, Figure 7-12), parking brake lever and cross-shaft assembly will fall.

- (2) Using proper support, remove parking brake lever and cross-shaft assembly (7) mounting hardware from the lever mount and pillow block.
- (3) Remove pull rod (3) from clevis (4), remove nuts (1) and coupler (2) from rod (3). Remove cotter pin (5) from clevis pin (6) and remove clevis pin (6) from clevis (5) and lever (7)
- (4) The lever arms and handle of the parking brake lever and cross-shaft assembly (7) are attached to the cross-shaft with 5/16 roll pin, do not remove unless repair or replacement is required.

b. Cleaning. Refer to paragraph 6-2. b for general cleaning procedures.

- c. Inspection. Refer to paragraph 6-2 c for general inspection procedures.
- d. Repair or Replacement. Refer to paragraph 6-2. d. for general repair or replacement procedures.
- e. Assembly. To assemble the parking brake lever and cross-shaft assembly, proceed as follows:
 - (1) Assemble two jam nuts (1, Figure 7-12) onto pull rod (3). Assemble coupler (2) to short threaded end of pull rod (3) and screw the other end of the rod (3) into clevis (4) Assemble rod & clevis to cross-shaft lever arm (7) and secure using clevis pin (6) and cotter pin (5).
 - (2) Position the parking brake lever and cross-shaft assembly (Figure 7-12) underneath the trailer frame and loosely attach the parking brake lever and cross-shaft assembly (7) to the trailer frame with its mounting hardware Put the cross-shaft pillow block on the end of the cross-shaft, and secure to the bottom of the frame with the pillow block mounting hardware. Tighten lever arm hardware.
 - (3) Attach parking brake cable (18, Figure 7-9) to coupler (2, Figure 7-12), adjust parking brake tensions and tighten jam nuts (1).

6-19. BRAKE ASSEMBLY (See Figure 7-10): The following paragraphs contain disassembly, cleaning, inspection, repair or replacement and assembly instructions for the trailer unit brake assembly.

- a. Disassembly. Disassemble the brake assembly only to the extent necessary to repair or replace a defective part or parts.
 - (1) It is not necessary to remove brake assembly hardware (15, 16, 17 Figure 7-9) to disassemble the brake assembly. Remove for replacement purposes.
 - (2) Disassemble the brake assembly (Figure 7-10) in the order of the assigned index number (Figure 7-10). Use brake spring pliers to remove and install springs (2).
- b. Cleaning. Refer to paragraph 6-2. b. for general cleaning procedures.
- c. Inspection. Refer to paragraph 6-2. c. for general inspection procedures.
- d. Repair or Replacement. Refer to paragraph 6-2. d. for general repair or replacement. procedures.
- e. Assembly. Assemble brake assembly (Figure 7-10) in the reverse of disassembly (See paragraph 6-19. a.).

6-20. TEST: The following contain the information for testing a system (s) component (s) on the CT-1 Commercial Trailer Unit.

- a. Refer to Section IV, paragraph 4-3 and proceed as required.

SECTION VII.

7-1 GENERAL The unit covered by the illustrated parts breakdown, is the Commercial Trailer, Model CT-1. The Model CT-1 trailer is a 5000 lb. gross weight general purpose trailer and is manufactured by the Davey Compressor Company (FSCM 16004), Cincinnati, Ohio 45242. Current usage is in conjunction with, and in support of part number 83208 and 83209, Type I and Type II Service Units respectively.

7-2 MAINTENANCE PARTS LIST The Illustrated parts list follows:

7-1

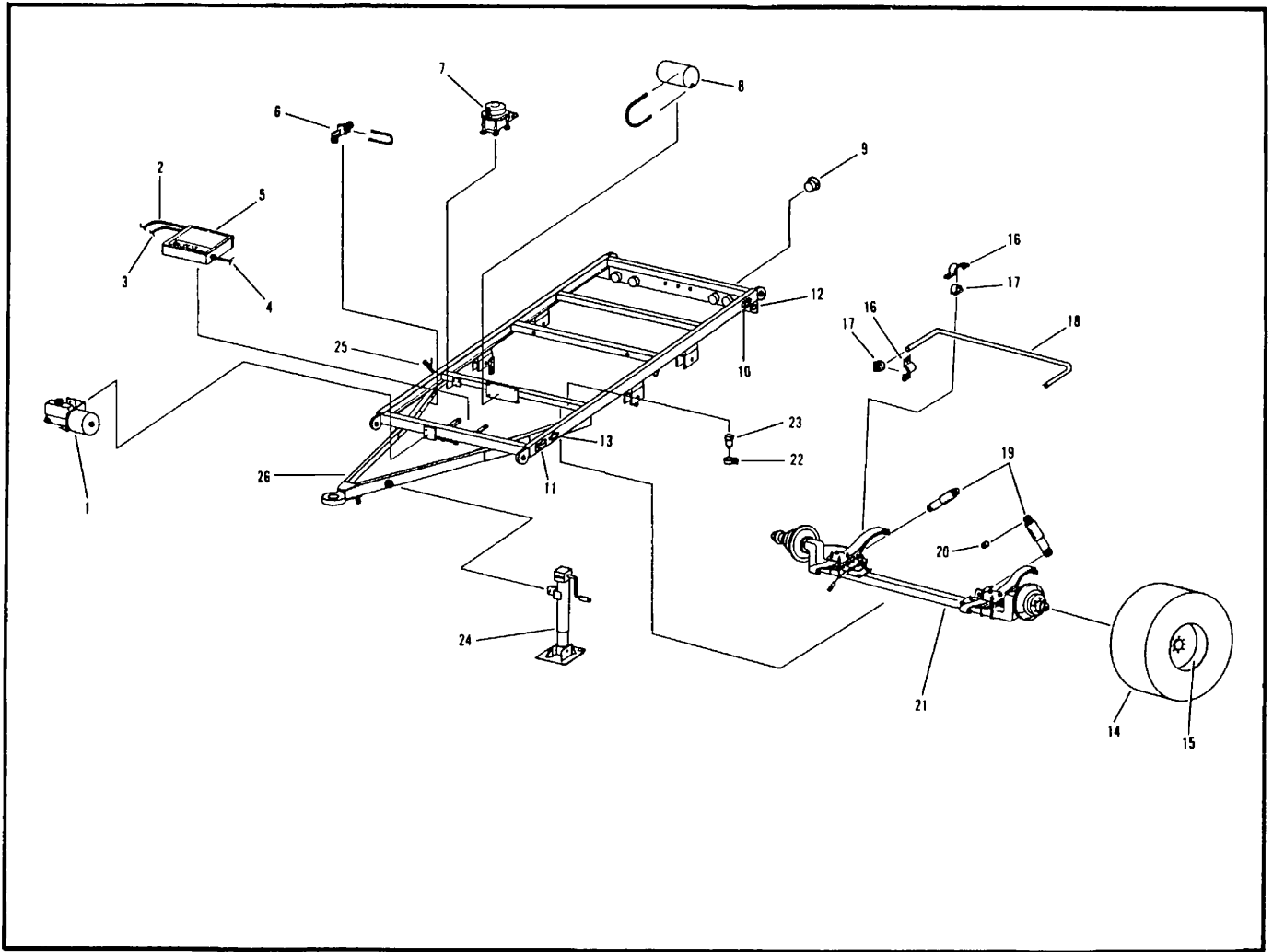

Figure 7-1. Trailer Assembly, Commercial

FIGURE & INDEX NUMBER	PART NUMBER	DESCRIPTION							QTY PER ASSY	USABLE ON CODE
		1	2	3	4	5	6	7		
7-1	86169	.							1	
-1	85862	.							1	
	82991	.							1	
	28842	.							1	
	443335	.							4	
	120233	.							4	
-2	85897	.								1
	down)									
-3	85898	.								1
	66989	.							2	
	273771	.							2	
-4	85905	.								1
	51206	.								
	132760	.							30	
	85915	.							30	
	49311	.							4	
-5	85923	.								1
	86151	.							1	
	69738	.							4	
	274473	.							4	
	9416918	.							4	
	86135	.							1	
	443335	.							3	
	122145	.							3	
	120394	.							3	
-6	82964	.							2	
	28842	.							4	
	86209	.							2	
	443333	.							4	
-7	82967	.							1	
	85882	.							1	
	120233	.							3	
	443335	.							3	
	28842	.							2	
	44294	.							1	
-8	85860	.							1	
	85861	.							2	
	443333	.							4	
	45229	.							1	
	219200	.							1	
	79058	.							1	
	28836	.							1	
	14026	.							1	
-9	85866	.							4	
	120221	.							12	
	190254	.							12	

FIGURE & INDEX NUMBER	PART NUMBER	DESCRIPTION							QTY PER ASSY	USABLE ON CODE
		1	2	3	4	5	6	7		
-10	64431	.							5	
	132908	.							20	
-11	64432	.							2	
	132908	.							8	
-12	45890	.							4	
	273771	.							8	
-13	45891	.							4	
	273771	.							8	
-14	83213	.							3	
-15	83214	.							3	
	82776	.							3	
-16	85993-1	.							4	
-17	85993-2	.							4	
-18	85992	.							1	
	122267	.							8	
	272683	.							8	
-19	85964	.							2	
	9430552	.							2	
	78693	.							2	
	67923	.							4	
-20	86219	.							2	
	86220	.							2	
		.								
	120396	.							2	
	67923	.							4	
	442832	.							2	
-21	85859	.							1	
	86000	.							1	
	443342	.							2	
-22	66989	.							1	
	85886	.							1	
		.								
	274825	.							1	
	9416918	.							1	
-23	85886	.							1	
		.								
	28836	.							1	
	144011	.							1	
-24	85943	.							1	
-25	86215	.							1	
		.								
	443335	.							4	
	122145	.							4	
-26	85863	.							1	
.		.								

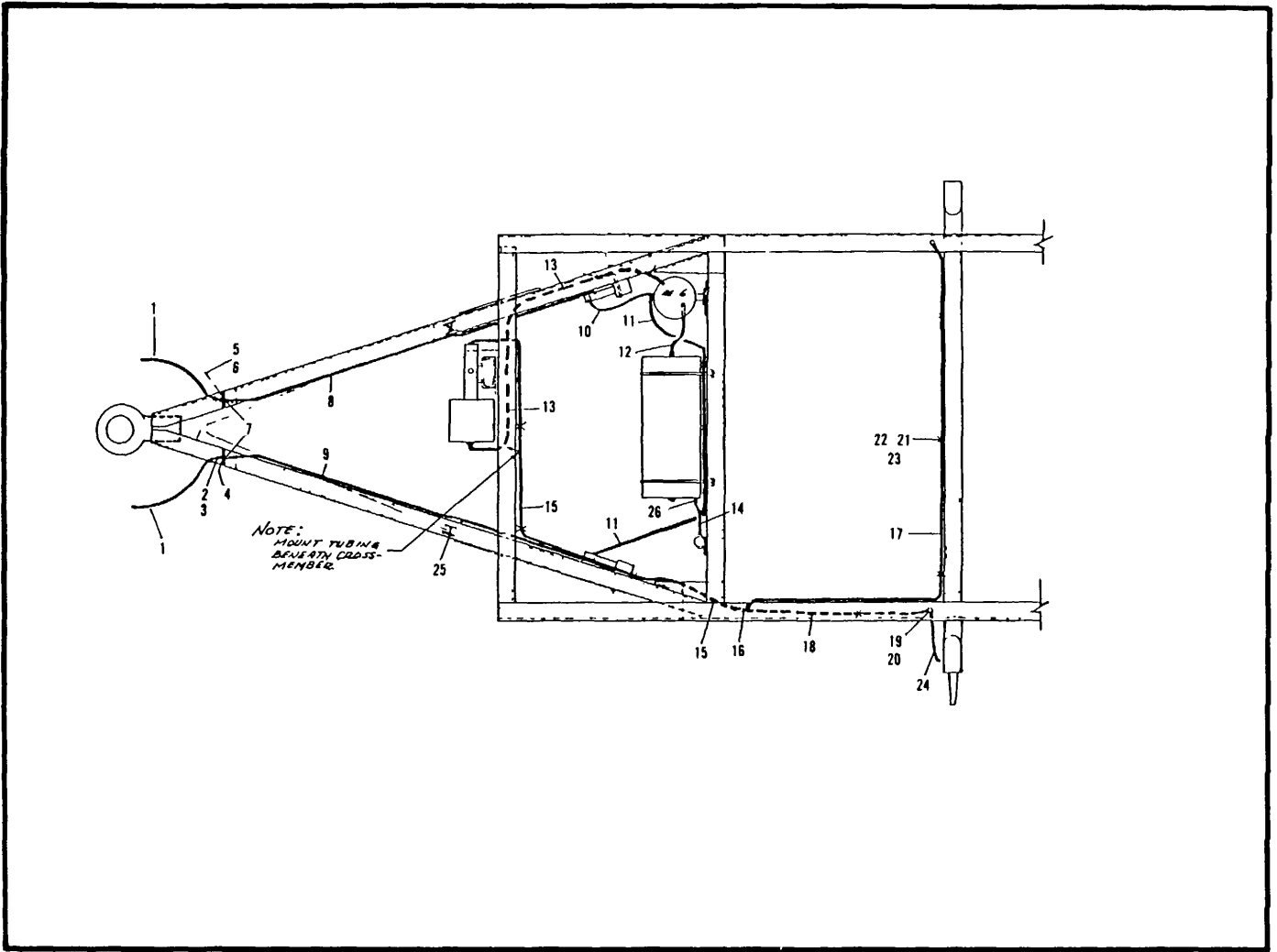

Figure 7-2. Hose and Tubing Assemblies

FIGURE & INDEX NUMBER	PART NUMBER	DESCRIPTION							QTY PER ASSY	USABLE ON CODE
		1	2	3	4	5	6	7		
7-2	NO NUMBER	.HOSE AND TUBING ASSEMBLIES							REF	
- 1	85875	.HOSE ASSY, AIR, SERVICE & EMERGENCY							2	
- 2	83133	.ADAPTER, 1/4FPT X 1/4MPT							2	
- 3	83143-2	.COUPLING, BULKHEAD							2	
-4	83318	.TAG, CONNECTION, EMERGENCY.....							1	
-5	83319	.TAG, CONNECTION, SERVICE.....							1	
- 6	145369	.DRIVE SCREW #4 x 3/161n.lg							4	
- 7	28836	.CONNECTOR, STRAIGHT 1/4MPT X 1/4Tube.....							2	
- 8	85879-1	.TUBE ASSY, CONN TO AIR FILTER (SERV)							1	
	273771	.SCREW, SERR.HD 1/4-20 x 1/2in.lg.(AP)							4	
- 9	85879-2	.TUBE ASSY CONNTO AIR FILTER (EMERG)							1	
	11031	.CUP, TUBING (AP).....							4	
-10	85880	.TUBE ASSY, FILTER TO RE-6 Valve							1	
-11	85881	.TUBE ASSY, FILTER(EMER) TO RE-6 VALVE							1	
-12	85883	.TUBE ASSY, 3/8 RELAY VAL TO AIR RESERVOIR.....							1	
-13	85884	.TUBE ASSY, RELAY VAL TO POWER CLUSTER							1	
-14	85885	.TUBE ASSY, AIR RESERVIOR TO AUTO DRAIN.....							1	
-15	85887	.TUBE ASSY, POWER CLUSTER TOBULKHEAD TEE ..							1	
-16	K-209129	.TEE BULKHEAD 1/4Tube							1	
-17	85888	.TUBE ASSY BULKHD TEE TO CURB SIDE BULICHD .							1	
		.ELBOW								
-18	85889	.TUBE ASSY BULKHD TEE TO ROAD SIDE BULIHD....							1	
		.ELBOW								
-19	82983	.BULKHEAD ELBOW 1/4 Tube							2	
-20	82982	.NUT, BULKHD ELBOW							2	
-21	11031	.CLIP, TUBING							16	
-22	120854	.SCREW, SERR.HD 1/4-20 x 5/8in.lg.(AP)							16	
-23	9416918	.NUT, SERR.HD., 1/4-201n.lg							16	
-24	85995	.BRAKE LINE, BULKHD ELBOW TO WHEEL							2	
-25	83178	.COUPLER DUMMY							2	
-26	14026	.DRAIN COCK							1	

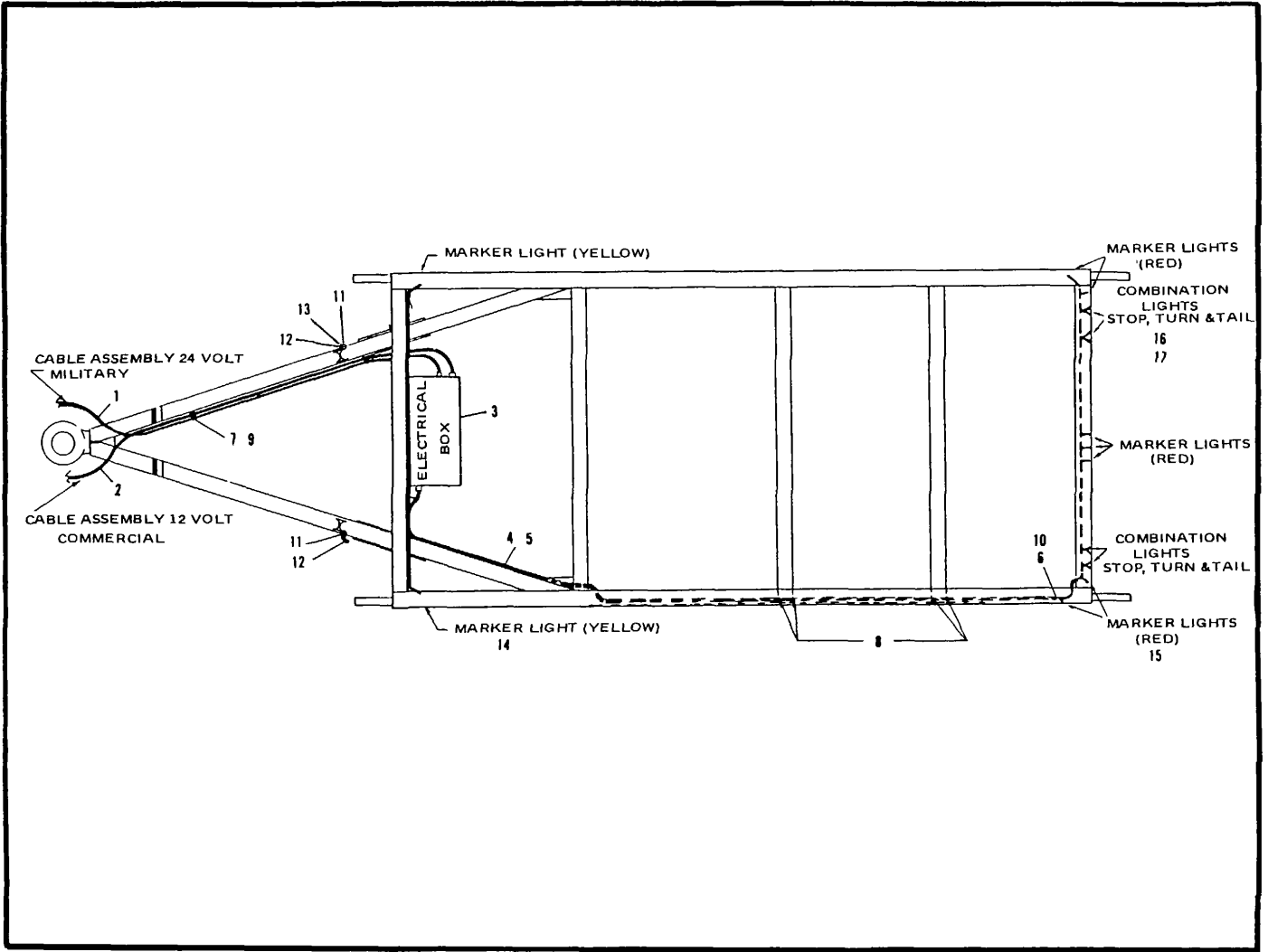

Figure 7-3. Electrical System
7-7

FIGURE & INDEX NUMBER	PART NUMBER	DESCRIPTION							QTY PER ASSY	USABLE ON CODE
		1	2	3	4	5	6	7		
7-3	86132	ELECTRICAL SYSTEM LAYOUT							REF	
- 1	85897	CABLE ASSY, MILITARY, 24V (See figure 7-4 for breakdown)							1	
- 2	85898	CABLE ASSY, 12V, COMMERCIAL (See figure... 7-5 for breakdown)							1	
- 3	85923	BOX, ELECTRICAL (See figure 7-7 for break- down)							1	
- 4	85905	WIRING HARNESS (See figure 7-6 for break- down)							1	
- 5	51206	COVER, PROTECTIVE LOOM, 129+3/-O IN.								
- 6	85915	CLIPS, PLUG.....							30	
- 7	66989	CLAMP, CABLE, 1 1/2.....							2	
- 8	49311	GROMMET							4	
- 9	273771	SCREW, SERR FLG HEX HD 1/4-20 x 1/2							2	
-10	132760	SCREW, RD.HD #8-32 x 1/2							30	
-11	27536	KEY RING.....							2	
-12	86140	CLIP, ELECTRICAL CONNECTOR.....							2	
-13	86141	S-WIRE LENGTH							1	
-14	64432	MARKER/CLEARANCE LIGHT, AMBER.....							2	
	132911	SCREW, RD.H., #10-32 x 5/8 (AP)							8	
	120217	WASHER, SPLT, #10 (AP)							6	
	178378	WASHER, INT/EXT LOCK, #10 (AP)							2	
-15	64431	MARKER/CLEARANCE LIGHT, REDD.....							7	
	132911	SCREW, RD.HD., #10-32 x 5/8 (AP)							28	
	120217	WASHER, SPLT, #10 (AP)							9	
	9411893	NUT, LOCK #10-32 (AP)							12	
	178378	WASHER, INT./EXT LOCK, #10 (AP)							7	
-16	85866	COMBINATION LIGHT							4	
	132911	SCREW, RD.HD., #10-32 x 5/8 (AP)							12	
	9411893	NUT, LOCK #10-32 (AP)							12	
-17	86230	PIGTAIL ASSY, COMBINATION LIGHTS.....							2	

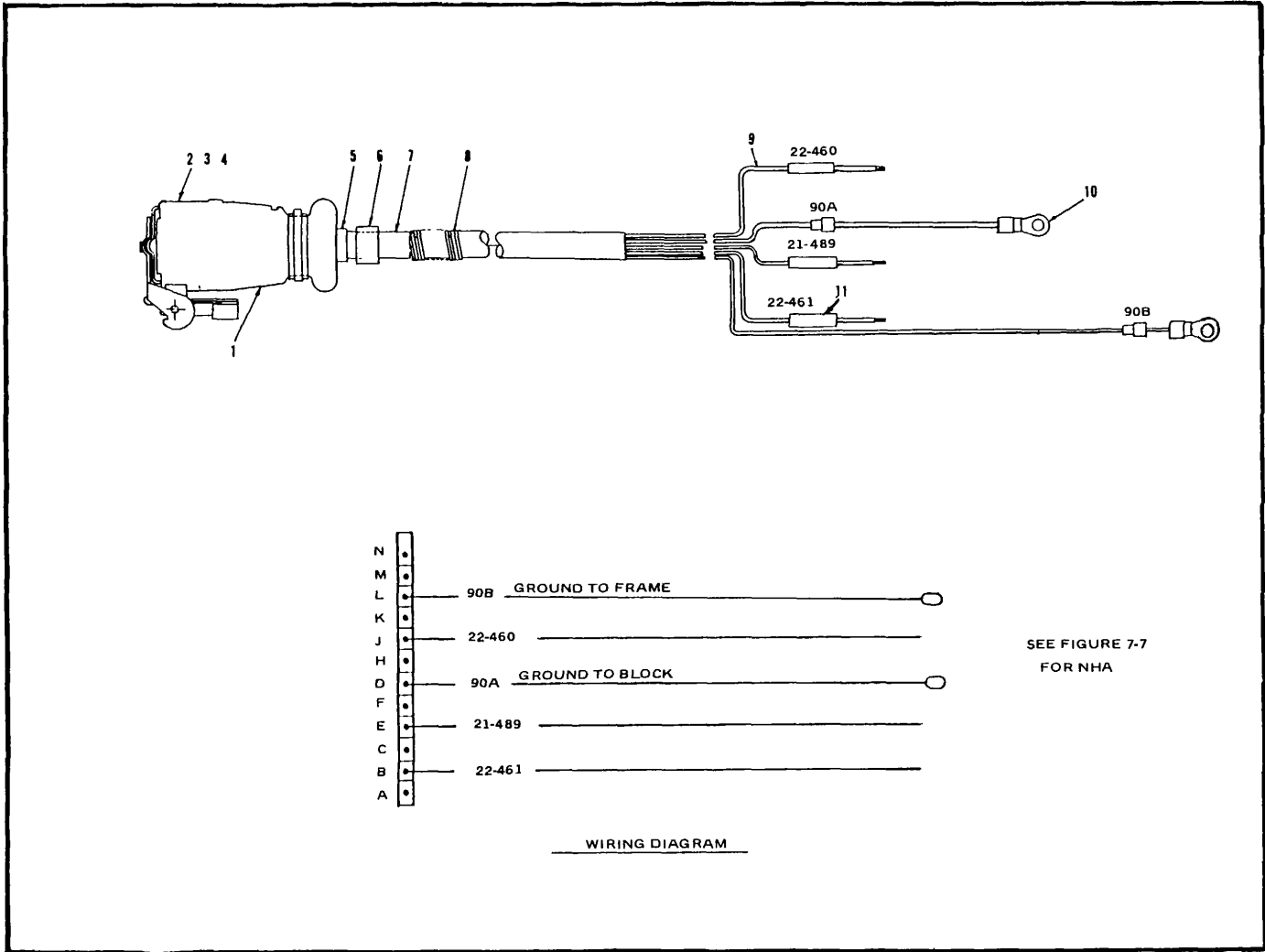
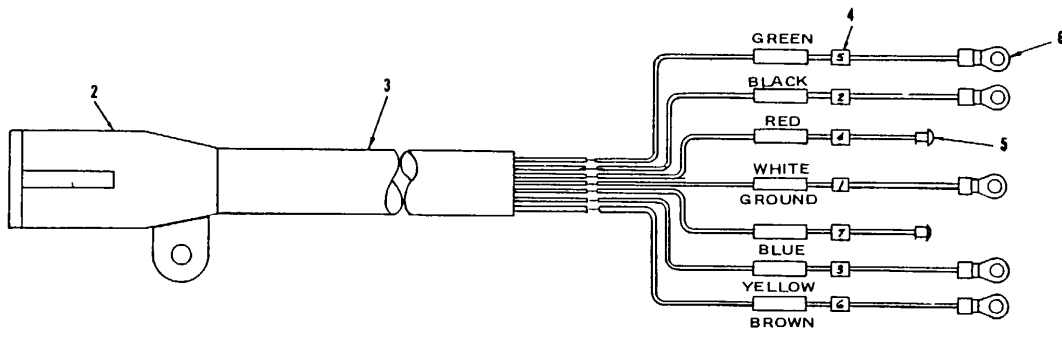
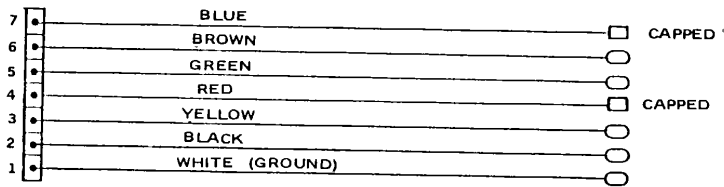

Figure 7-4. Cable Assembly, 24 Volt
7-9

FIGURE & INDEX NUMBER	PART NUMBER	DESCRIPTION							QTY PER ASSY	USABLE ON CODE
		1	2	3	4	5	6	7		
7-4	85897	CABLE ASSY., 24V (SEE FIG 7-6 FOR NHA) ...							REF	
-1	MS75020-1	CONNECTOR.....							1	
-2	8724316	BODY ASSY							1	
-3	8701274	INSERT.....							1	
-4	7716521	CONTACT.....							1	
-5	7358188	BUSHING							1	
-6	MS39020-3	BAND MARKER.....							1	
-7	MIL-C-13486-10	CABLE (4 CONDUCTOR).....							1	
-8	MS39134-1	SPRING.....							1	
-9	MIL-C-13486	WIRE, 14 GA							5	
-10	MS-25036-8	TERMINAL.....							2	
-11	MS-39020-1	BAND MARKER.....							5	



1



SEE FIGURE 7-7
FOR NHA

WIRING DIAGRAM

Figure 7-5. Cable Assembly, 12 Volt

FIGURE & INDEX NUMBER	PART NUMBER	DESCRIPTION							QTY PER ASSY	USABLE ON CODE
		1	2	3	4	5	6	7		
7-5	NO NUMBER								REF.	
-1	85898								1	
-2	85899								1	
-3	85927								90"	
-4	NO NUMBER								7	
-5	AD81674								2	
-6	24861								5	

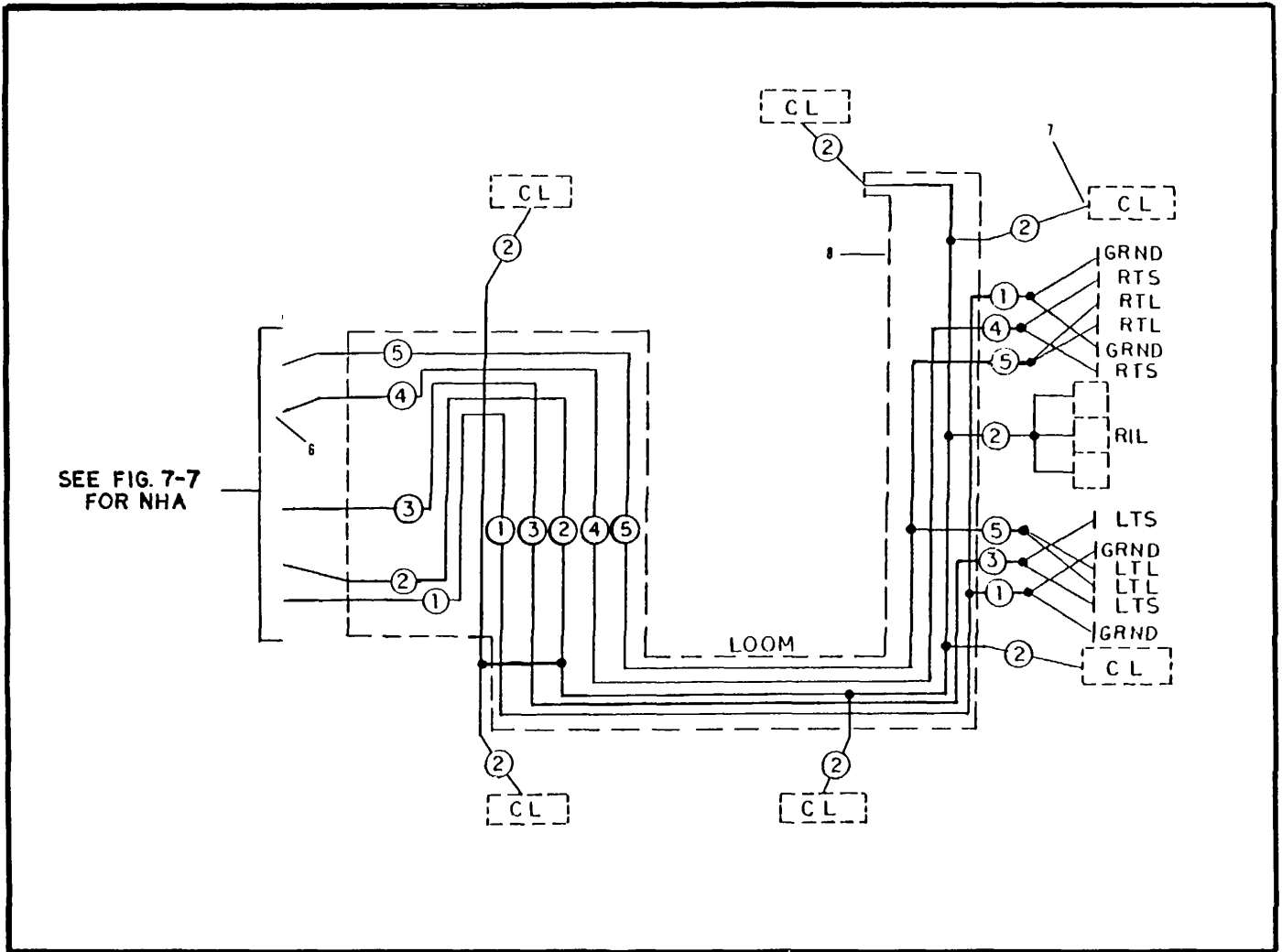

Figure 7-6. Trailer Chassis Wiring Harness

FIGURE & INDEX NUMBER	PART NUMBER	DESCRIPTION							QTY PER ASSY	USABLE ON CODE
		1	2	3	4	5	6	7		
7-6	85905	WIRING DIAGRAM, TRAILER CHASSIS							REF	
-1	29085	WIRE, 14 GA GROUND (WHITE) 148 1/4"							1	
-2	27422	WIRE, 14 GA MARKER CLEARANCE (BLACK) ..							1	
		226 3/4"								
-3	29185	WIRE, 14 GA LEFT TURN, STOP (YELLOW)							1	
		110 1/2"								
-4	27424	WIRE, 14 GA RIGHT TURN, STOP (GREEN) 139"							1	
-5	11022	WIRE, 14 GA SERVICE, TAIL (BROWN) 148 1/4."							1	
-6	24861	TERMINAL, #10.....							5	
-7	83145	CONNECTOR, MALE							30	
	82530	CONNECTOR, FEMALE (SIZE 2)							30	
-8	51206	LOOM, FORMED.....							AR	

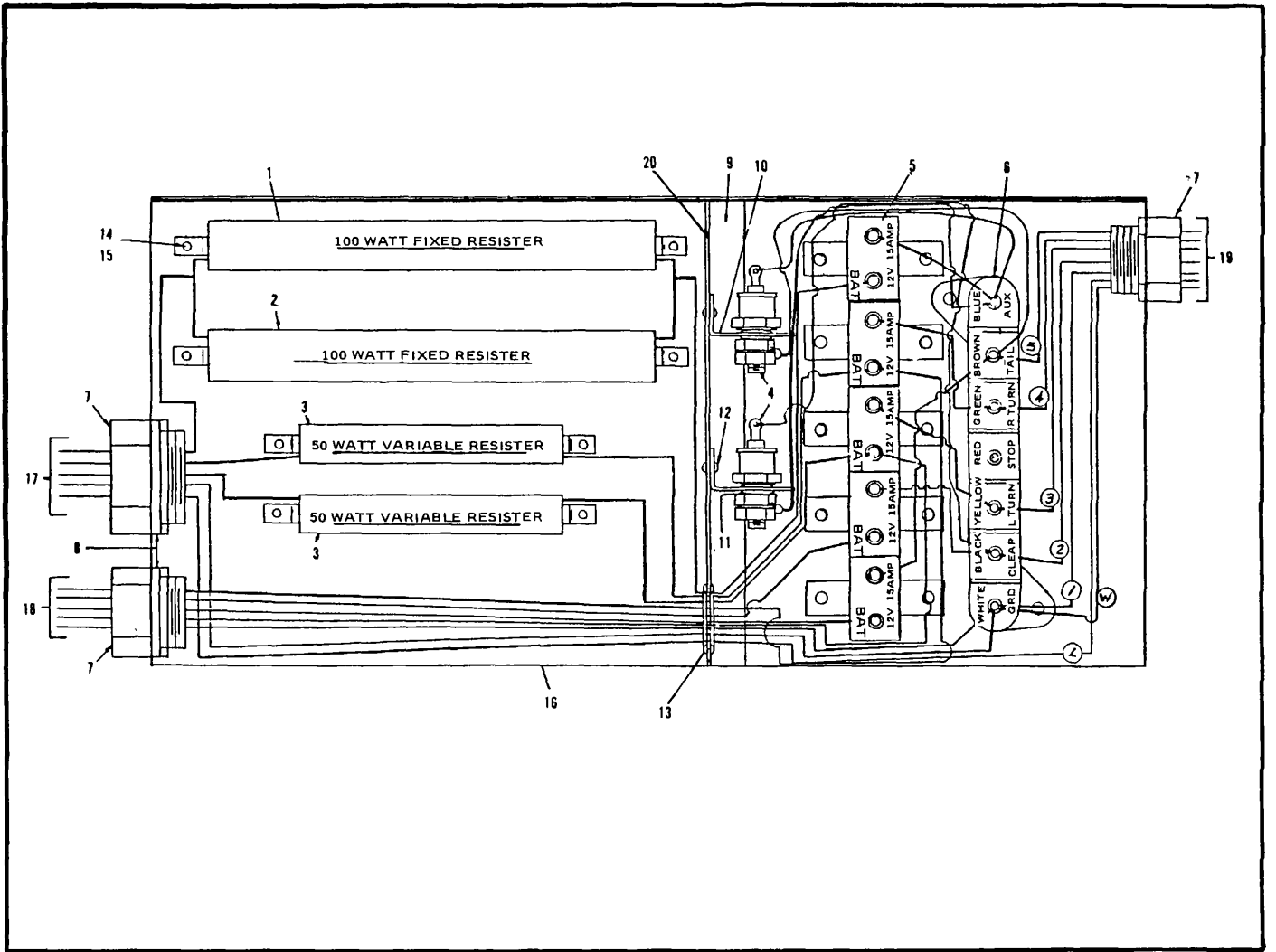

Figure 7-7. Electrical Box Assembly

FIGURE & INDEX NUMBER	PART NUMBER	DESCRIPTION							QTY PER ASSY	USABLE ON CODE
		1	2	3	4	5	6	7		
7-7	85923	.							REF	
-1	85911	.							1	
-2	85912	.							1	
-3	85913	.							2	
-4	85916	.							2	
-5	85910	.							5	
-6	85899	.							1	
-7	85922	.							3	
-8	86128	.							3	
-9	85933	.							1	
-10	85934	.							2	
-11	85944	.							2	
-12	69738	.							4	
-13	49311	.							1	
-14	9411893	.							20	
-15	436750	.							20	
-16	85914	.							1	
-17	85897	.							REF	
-18	85898	.							REF	
-19	85905	.							REF	
-20	K251295	.							11.5"	

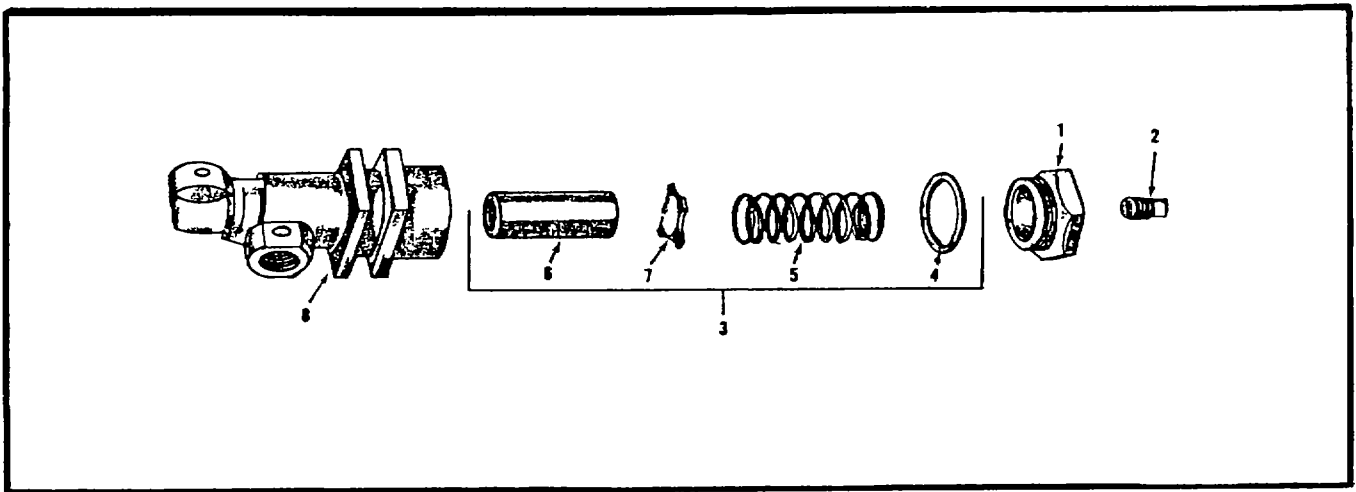

Figure 7-8. Air Filter

FIGURE & INDEX NUMBER	PART NUMBER	DESCRIPTION							QTY PER ASSY	USABLE ON CODE
		1	2	3	4	5	6	7		
7-8	82964	AIR FILTER (SEE FIG 7-1 FOR NHA).....							REF	
-1	7979613	. NUT, COVER.....							1	
-2	MS20913	. PLUG, SQ. HD.....							1	
-3	8332695	. KIT, SERVICE.....							1	
-4	8329823	. GASKET.....							1	
-5	7979612	. SPRING.....							1	
-6	7411081	. ELEMENT, FILTER.....							1	
-7	7979614	. SUPPORT, SPRING.....							1	
-8	7415748	. BODY, FILTER.....							1	
7-17										

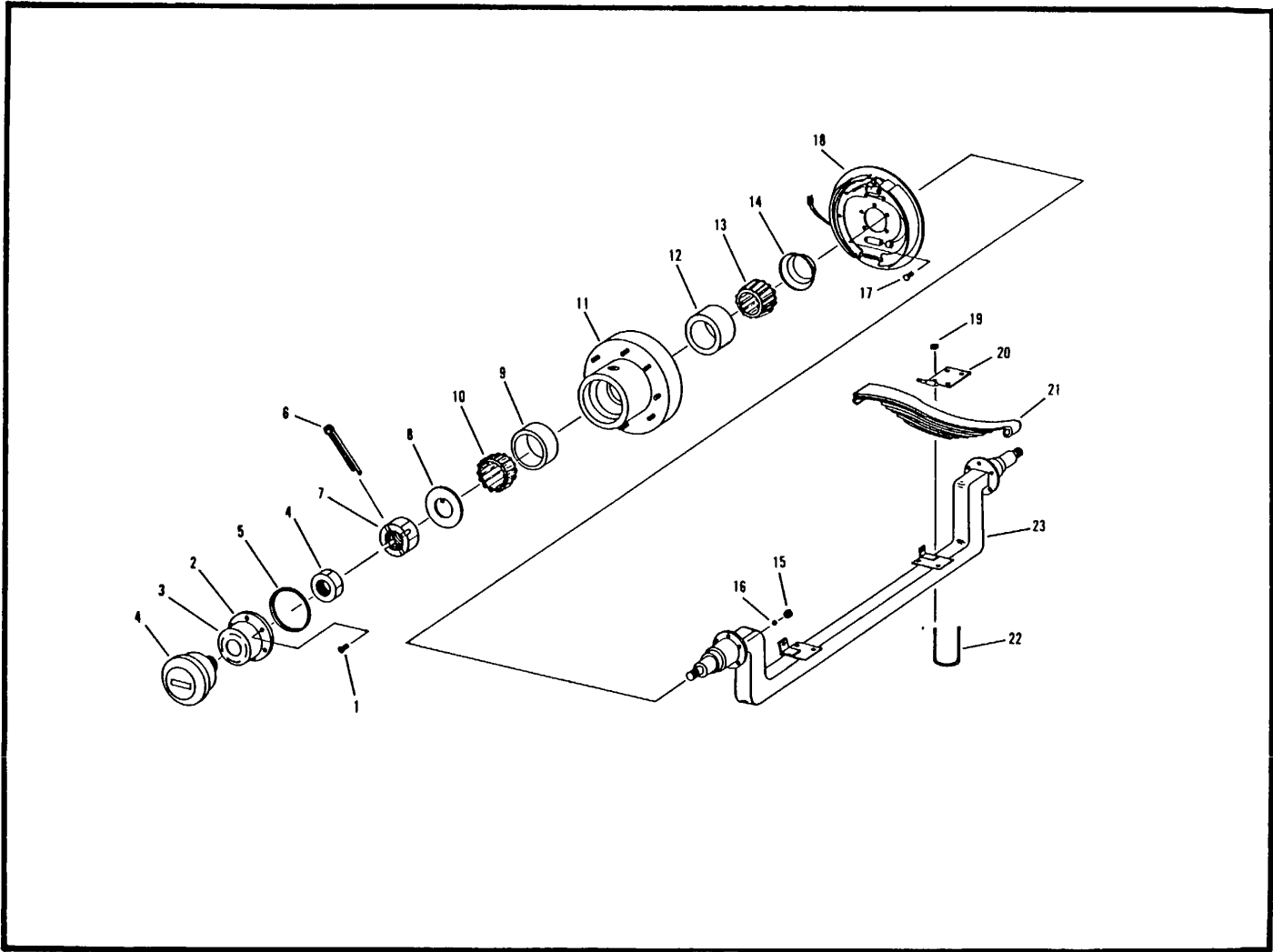

Figure 7-9. Axle Assembly

FIGURE & INDEX NUMBER	PART NUMBER	DESCRIPTION 1 2 3 4 5 6 7	QTY PER ASSY	USABLE ON CODE
7- 9	85859	AXLE ASSEMBLY (SEE FIG 7-1 FOR NHA).....	REF	
- 1	4903-11	SCREW, SOCKET HD.....	6	
- 2	6335-3	RING, CAP	2	
- 3	6335-1	CAP, SEE THROUGH	2	
- 4	5293-2	HUBODOMETER.....	1	
- 5	6335-2	GASKET, CAP	2	
- 6	4800-5	PIN, COTTER	2	
- 7	4600-17	NUT, SPINDLE	2	
- 8	4702-6	WASHER, SPINDLE.....	2	
- 9	6168	CUP, OUTER	2	
-10	6073	BEARING, OUTER CONE	2	
-11	3628-1	HUB	2	
-12	6334	SEAL, OIL	2	
-13	6072	BEARING, INNER CONE	2	
-14	6169	CUP, INNER	2	
-15	4601-5	NUT, HEX	10	
-16	4700-4	WASHER, LOCK.....	10	
-17	4901-7	BOLT, MOUNTING	10	
-18	8214-12	BRAKE ASSY (R.H.)CURBSIDE (See figure 7-10	1	
		for breakdown)		
	8214-13	BRAKE ASSY (L.H.) ROADSIDE(See figure 7-10.....	1	
		for breakdown)		
-19	4601-8	LOCK NUT 8		
-20	5289-11	TIE PLATE & STUD.....	2	
-21	1-4010-5	SPRING	2	
-22	5101-3	U-BOLT	4	
-23	86182	BEAM ASSY., AXLE	1	
7-19				

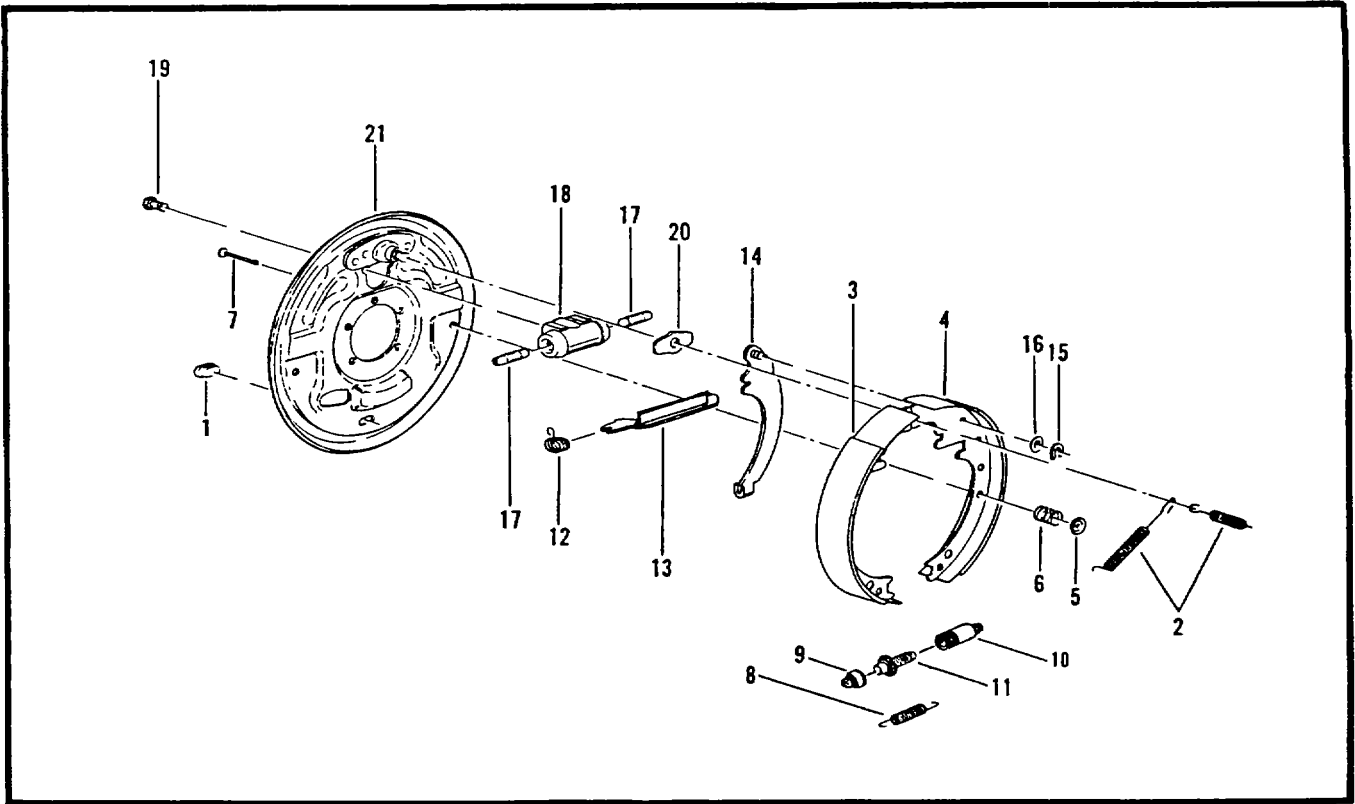

Figure 7-10. Brake Assembly

FIGURE & INDEX NUMBER	PART NUMBER	DESCRIPTION	QTY							USABLE ON CODE	
			1	2	3	4	5	6	7		PER ASSY
7-10	8214-13	BRAKE ASSEMBLY, LH (22938) (SEE FIG 7-9 FOR NHA)								REF	
	8214-12	BRAKE ASSEMBLY, RH (22938) (SEE FIG 7-9 FOR NHA)								REF	
-1	301055	GROMMET (22938)								1	
-2	8214-24	SPRING, ANCHOR, (22938)								2	
-3	8214-39	SHOE AND LINING ASSY, BRAKE SECONDARY								1	
		(22938)									
-4	8214-38	SHOE AND LINING ASSY, BRAKE PRIMARY (22938)								1	
-5	8214-27	CUP, SHOE HOLDDOWN (AP) (22938)								4	
-6	8214-26	SPRING, HOLDDOWN, (AP) (22938)								2	
-7	8214-25	PIN, HOLDDOWN (AP) (22938)								2	
-8	8214-22	SPRING, ADJUSTING SCREW, (22938)								1	
-9	8214-40	ADJUSTING SCREW ASSY (22938)								1	
		SOCKET, ADJUSTING SCREW								1	
		SCREW ASSY								1	
-10		NUT, ADJUSTING SCREW								1	
-11		SCREW, ADJUSTING								1	
-12	8214-31	SPRING, STRUT, (22938)								1	
-13	8214-19	STRUT, LEVER (22938)								1	
-14	8214-16	LEVER ASSY, LEFT HAND (SHOWN) (22938)								1	
	8214-17	LEVER ASSY, RIGHT HAND (22938)								1	

FIGURE & INDEX NUMBER	PART NUMBER	DESCRIPTION							QTY PER ASSY	USABLE ON CODE
		1	2	3	4	5	6	7		
-15	8214-30	RETAINER, LEVER (AP) (22938).....							1	
-16	8214-29	WASHER, RETAINER (AP) (22938)							1	
-17	8214-44	ROD, PUSH, CYLINDER (22938).....							2	
-18	8214-43	CYLINDER, BRAKE, LEFT HAND (SHOWN) (22938)							1	
	8214-42	CYLINDER, BRAKE, RIGHT HAND (22938)							1	
-19	47862	SCREW, CAP AND WASHER (AP) (22938)							2	
-20	8214-3	PLATE, GUIDE (22938).....							1	
-21	8214-37	PLATE ASSY, BACKING, LEFT HAND (SHOWN)							1	
	8214-36	PLATE ASSY, BACKING, RIGHT HAND (22938)							1	
7-21										

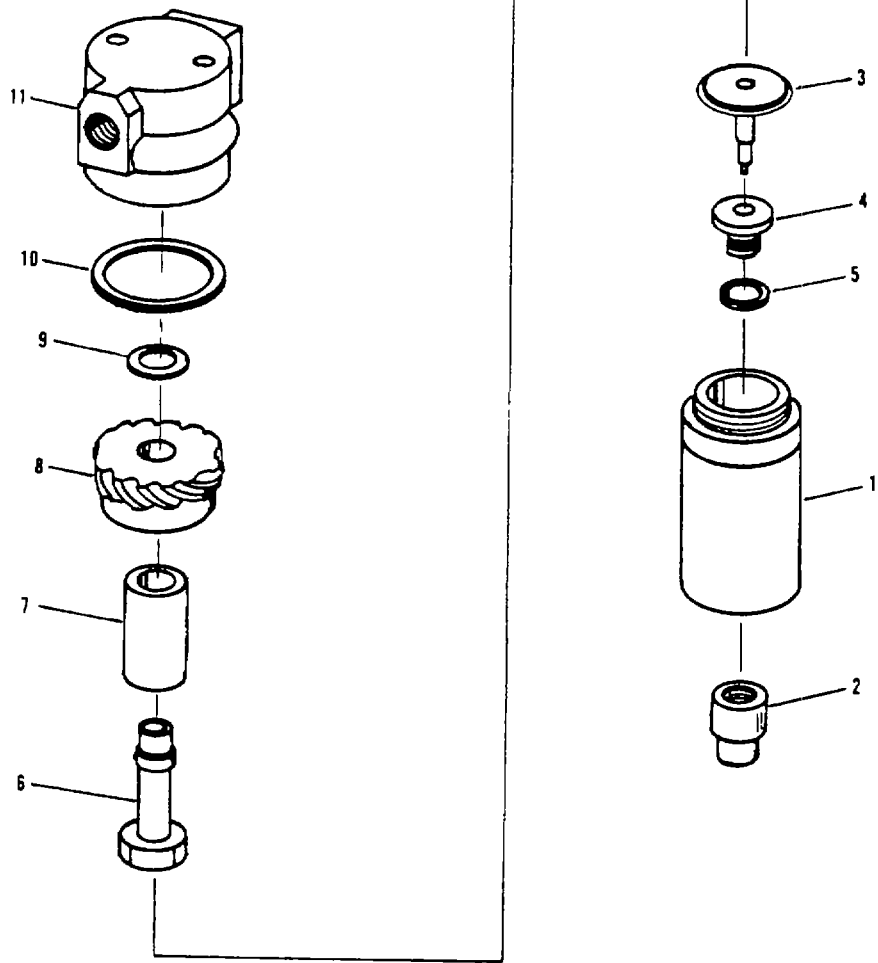

Figure 7-11. Automatic Drain Valve.

FIGURE & INDEX NUMBER	PART NUMBER	DESCRIPTION							QTY PER ASSY	USABLE ON CODE
		1	2	3	4	5	6	7		
7-11	85886	DRAIN VALVE, AUTO, 150 PSIG (SEE FIG 7-1 FOR NHA)							REF	
-1	3809-50	BOWL, METAL.....							1	
-2	3711-01	CONNECTOR.....							1	
-3	3639-51	VALVE							1	
-4	3636-50	CYLINDER, VALVE							1	
-5	2315-12	O-RING							1	
-6	3645-89	STUD, MOUNTING.....							1	
-7	5726-01*	ELEMENT, FILTER.....							1	
-8	5934-89*	LOUVER							1	
-9	5938-01*	GASKET							1	
-10	2315-24*	O-RING							1	
-11	NO NUMBER	HEAD, DRAIN VALVE							1	
*	3654-01	REPAIR KIT							AR	
7-23										

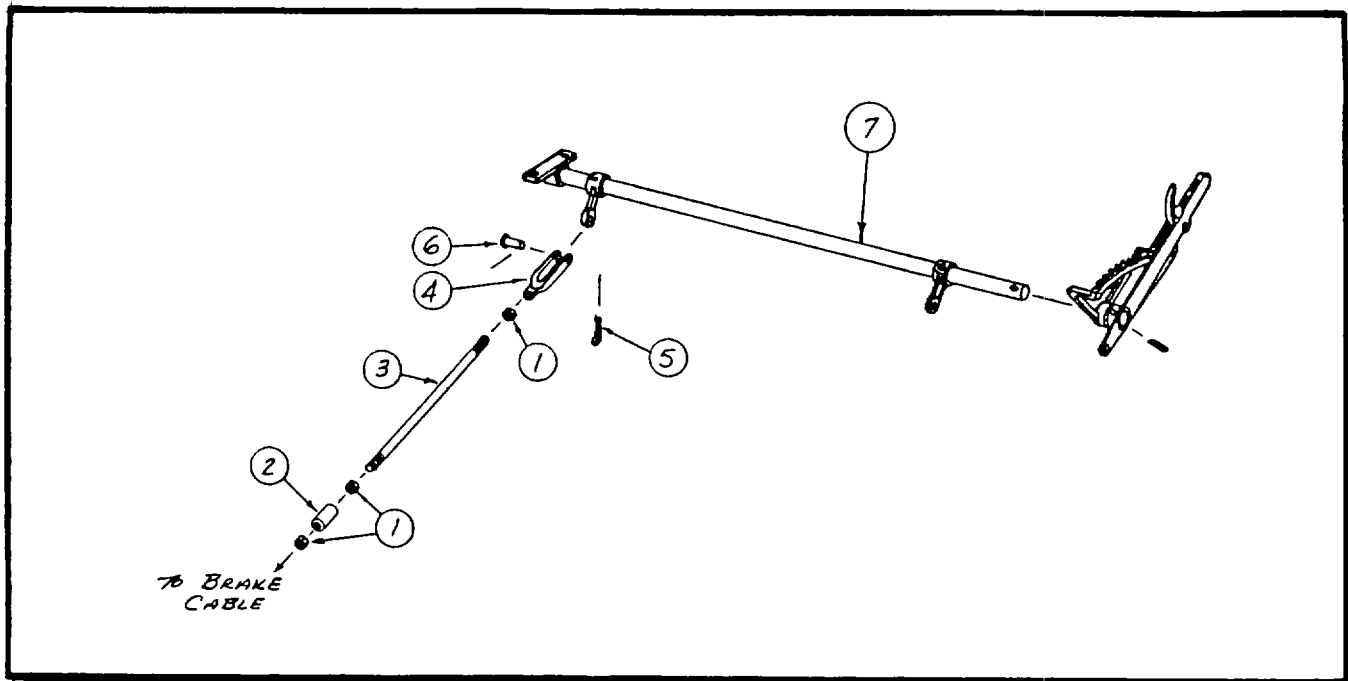

Figure 7-12. Parking Brake Assembly

FIGURE & INDEX NUMBER	PART NUMBER	DESCRIPTION	QTY PER ASSY	USABLE ON CODE
		1 2 3 4 5 6 7		
7-12	86215	PARKING BRAKE ASSEMBLY (SEE FIG 7-1 FOR NA)	REF	
- 1	120396	NUT, JAM, 3/8-24	6	
- 2	86217	COUPLER	2	
- 3	86216	PUL ROD, BRAKE	2	
- 4	11014	CLEVIS	2	
- 5	121224	PIN, COTTER, 3/32x1l.....	2	
- 6	10165	PIN, CLEVIS	2	
- 7	86213	CROSS SHAFT ASSEMBLY	1	
7-24				

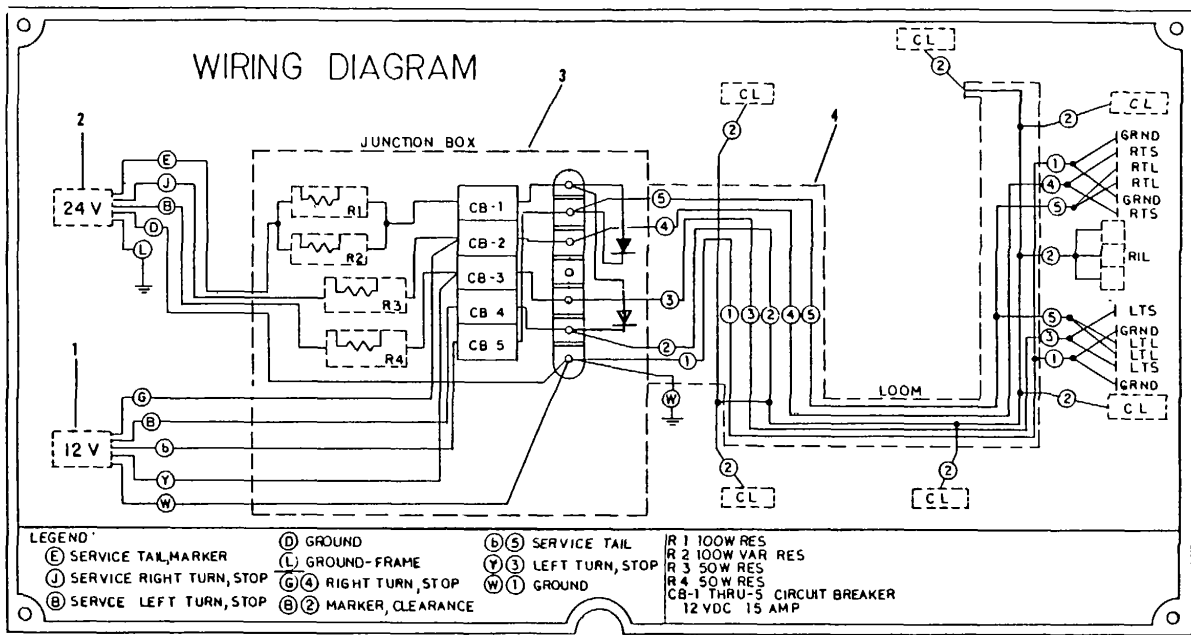

Figure 7-13. Wiring Diagram

FIGURE & INDEX NUMBER	PART NUMBER	DESCRIPTION 1 2 3 4 5 6 7	QTY PER ASSY	USABLE ON CODE
7-13 - 1	NO NUMBER 85898	WIRING DIAGRAM, TRAILER UNIT CABLE ASSEMBLY, 12V (See Figure 7-5 for BREAKDOWN)	REF REF	
- 2	85897	CABLE ASSEMBLY, 24V (See Figure 7-4 for breakdown)	REF	
- 3	85923	BOX, ELECTRICAL (See Figure 7-7 for break- down)	REF	
- 4	85905	WIRING HARNESS, TRAILER (See Figure 7-6 for breakdown)	REF	
7-26				

SECTION VII.

MANUFACTURER'S DATA AIR-OVER-HYDRAULIC POWER CLUSTER

Cutaway of Power Cluster —
equipped with cage type residual
pressure check valve.

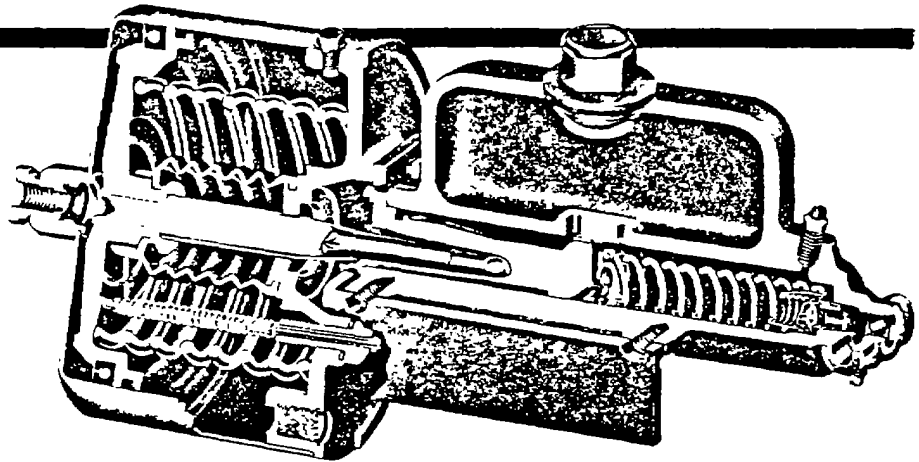

8-1. GENERAL

The power cluster, used in an air-over-hydraulic actuating system, has an air cylinder and a standard hydraulic brake master cylinder which are aligned upon the cluster mounting bracket. This unit provides a 15.1 pressure ratio so that a maximum 1500 psi hydraulic pressure is secured at approximately 100 psi applied air pressure. Units are produced in four sizes, matching the standard master cylinder sizes used on medium and heavy commercial vehicles.

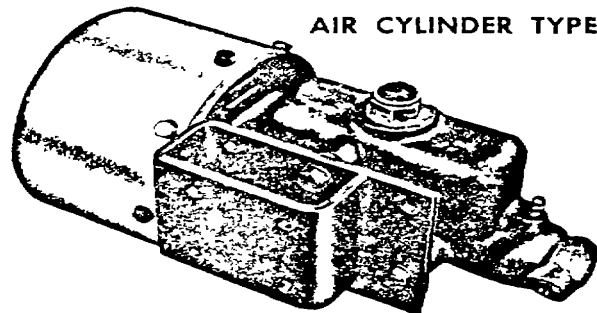

Power Cluster with 1-3/4" diameter hydraulic
cylinder and air cylinder power section

8-2. HOW THE CLUSTER WORKS

a. Air Cylinder' Air, entering, forces the piston and rod to stroke the hydraulic cylinder and compress the air piston return spring. The piston also strokes a spring loaded stroke indicator rod which extends through a drilled bolt, one of those mounting the air cylinder. The cylinder shell wall is sealed by a cup carried on the piston, which also carries a felt wiper that cleans and lubricates the wall. A boot stretched between the piston and the cylinder head excludes dust, moisture, and oil from the opening into the hydraulic cylinder. Air displaced on the atmospheric side of the air piston passes through a filtered breather located in the air cylinder head.

When air is released, the return spring forces the piston and rod back to static position in advance of the hydraulic cylinder. The stroke indicator rod follows the piston.

b Hydraulic Master Cylinder The standard master cylinder housing includes a brake fluid reservoir which is joined to the cylinder bore by intake and compensating (by-pass) ports.

In static position, fluid by-passes to compensate the closed hydraulic system for temperature expansion and contraction or seepage. During an application, initial piston movement seals off the by-pass, then the stroke displaces fluid, through an outlet check valve, into the system and pressure builds when this fluid movement ceases. A primary cup, ahead of the piston, seals the pressure system and the piston carries a secondary seal cup which prevents fluid loss at the open rear of the cylinder.

Upon release, a return spring forces the piston back to its stop faster than the displaced fluid can unseat the check valve and return, and a vacuum forms. Reservoir fluid ahead of the secondary cup is sucked through passages in the piston face, supercharging the system, and the fluid excess by-passes into the reservoir. The return spring also seats the outlet check valve to trap up to 18 psi residual pressure in the system. Residual pressure assists system sealing and raises the fluid boil point. The check valve also assists the service "bleeding" operation.

8-3. MAINTENANCE OF THE POWER CLUSTER

a. Should even a small air leak (slow bubbling when covered with suds) or a hydraulic pressure internal leak develop, a unit in brake service should be deadlined to avoid the possibility of a hazardous sudden complete failure. Many vehicle operators prefer scheduled maintenance.

b. At Lube or Oil Change: Clean dirt from area of fluid filler cap Remove cap and fill reservoir to within 1/2 to 3/8 inch of the top. For best results use super heavy duty brake fluid, SAE 70R-3, Wagner Lockheed No. 21B.

c. At Brake Adjustment - Inspection Brake hnlng clearance adjustment is needed when the stroke of the cluster travel indicator rod approaches

- 1 - 1-1/4 mches on units provding 1-1/2 inches total stroke
- 2 - 2-1/4 inches on units providing 2-9/16 inches total stroke

Also check cluster air cylinder for dents and leaks, hose or pipe connections for leaks and wear, arid hydraulic cylinder for an internal pressure leak.

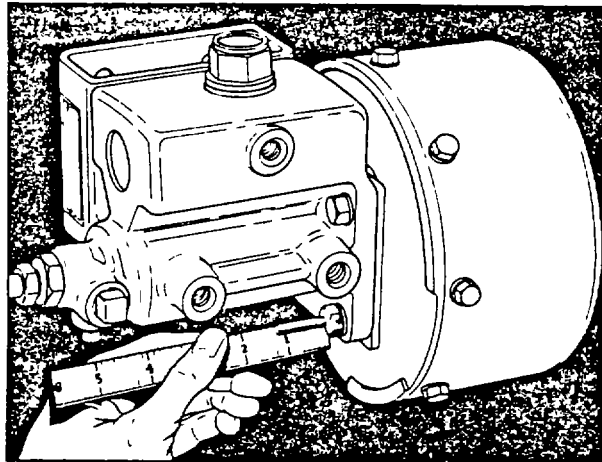

TRAVEL INDICATOR ROD STROKE

d. At Brake Re-line: Comprehensive Inspection of the power cluster and connections Some shops install new piston cups or a repair kit to assure trouble-free operation during the life of the new lining.

An air cylinder leak, except at the inlet fitting, is due to a worn piston cup, a dent or corrosion in the cylinder shell, or a piston loose on its rod

Internal pressure leak in the hydraulic cylinder, due to worn primary cup, pitted cylinder, or corrosion, is demonstrated by creep of the stroke travel indicator during an extended holding application at low pressure.

Fluid leak at the rear of the hydraulic cylinder is due to cylinder pitting or a worn secondary cup.

Should hydraulic pressure build and fall to release (brakes "lock up") the hydraulic by-pass is blocked by dirt or corrosion, or a swollen primary cup which extends over the port. A swollen cup indicates an improper or contaminated brake fluid.

Air in the hydraulic lines lengthens the stroke and must be bled from the system. At the cluster master cylinder, check for

Fluid level - low, below reservoir ports.

Filler cap vent - blocked, producing vacuum which sucks air past the piston secondary cup.

Secondary cup - worn, or pitted hydraulic cylinder.

Check valve - fails to retain residual pressure in system.

For servicing, it is more convenient to remove the cluster to a work bench. Remove filler cap and pour off brake fluid.

e. Air Cylinder Separate air cylinder from the cluster by removing fastening bolts. Separate cylinder shell from head by taking out shell cap screws (8, 5/16-18 x 5/8 inch) and slide shell from head and piston. Piston cup and wiper can be stopped from the piston. Piston, spring and boot can be pulled from head. Before assembling, lubricate the shell interior and saturate the piston cup and felt wiper with a light engine oil. Install boot in piston groove. Align piston and spring with head and compress them in order to snap boot into groove on head. Pass a small diameter drift through the shell air inlet and use it to hold the spring compression while guiding the shell over the piston and head.

f. Hydraulic Cylinder After removing the air cylinder, pick lock ring from groove in end of hydraulic cylinder bore. Internal parts should slide out or can be fished out. Do not overlook valve seat in end of bore Before assembling, lubricate cylinder bore and parts with brake fluid. Be sure that lock ring is seated firmly in groove and that piston returns against the stop plate.

PARTS DESCRIPTION POWER CLUSTER

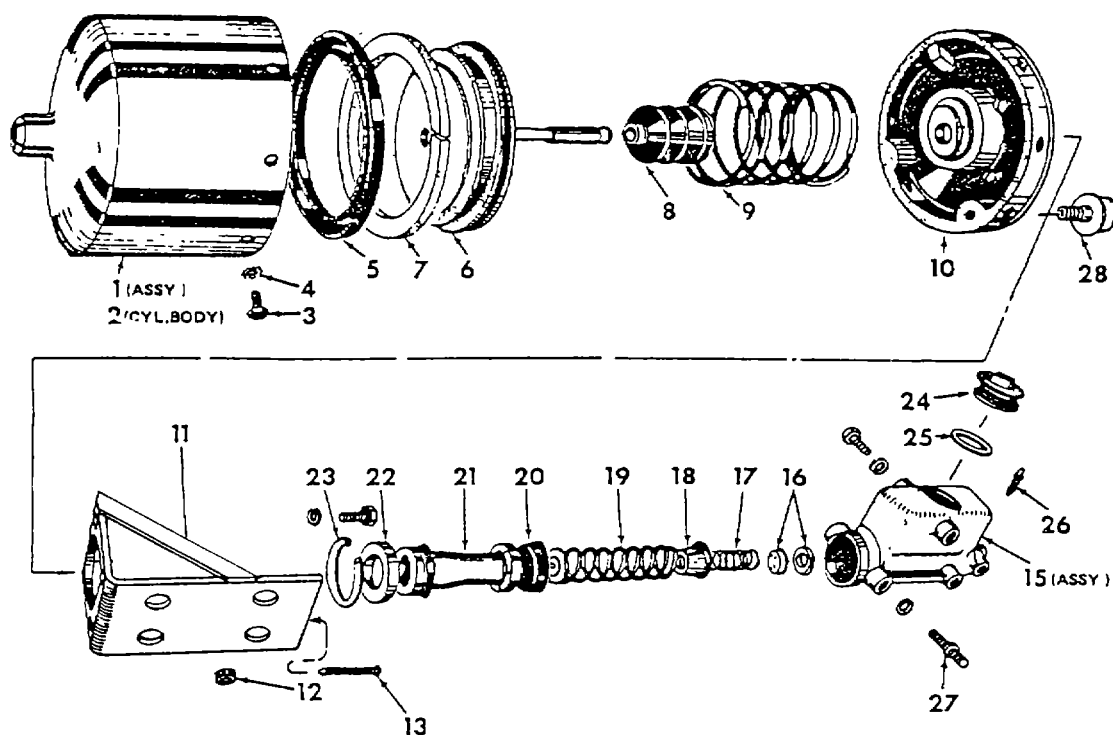

Air Cyl. Diameter	6"
Hyd. Cyl Diameter	1-1/2"
Stroke	1-1/2"
Replacement Units (complete)	AE838
Item 1. Air Cyl. Assy	AD834
Item 2. Shell, Air Cyl	AC2868
Item 15 Hydraulic Cyl Assy.	F677
Maintenance Kits (Parts indicated*)	A3075

- | | |
|--|--|
| <ul style="list-style-type: none"> 3. Screw (5/16"-18 x 5/8") 4. Lockwasher (5/16") *5. Cup, Air Piston 6. Piston and Rod, Air *7. Wiper, Air Cyl. *8. Boot, Air Piston Rod 9. Spring, Air Piston Return 10. Head, Air Cyl. 11. Bracket, Mounting 11a Bracket, Mounting 12. Spacer, Mounting 13. Indicator, Piston Stroke 14. Ring, Cyl. Sealing (A.F 840 only) 15. Hydraulic Cyl. Assy (see repl. unit) | <ul style="list-style-type: none"> *16. Check Valve 17. Spring, Valve Retainer 18. Retainer, Check Valve 19. Spring, Piston Retainer *20. Primary Cup *21. Piston Assy. 22. Stop Plate 23. Lock Ring 24. Filler Cap 24a Adapter, Filler Cap 25. Cap, Gasket 26. Bleeder Screw 27. Stud, Mounting 28. Breather-Filter |
|--|--|

(FSCM 06853)

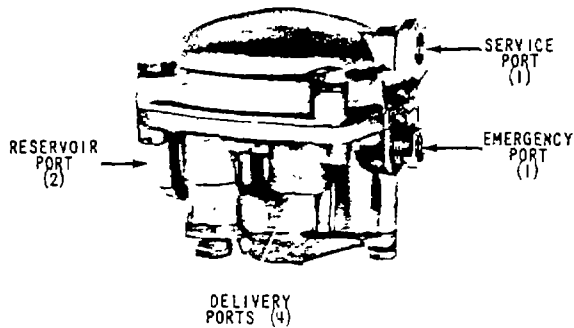
RE-6 RELAY EMERGENCY VALVE

EXTERIOR
Figure 1
Figure 1.

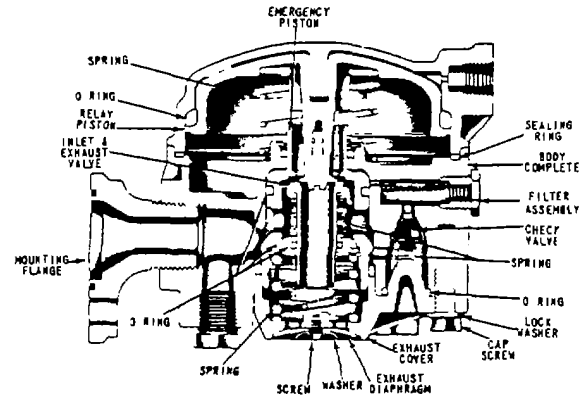

SECTIONAL
Figure 2
Figure 2.

DESCRIPTION

The Relay Emergency Valve is normally used in trailer braking systems. It is a dual function valve, combining the functions of a relay valve and an emergency valve.

The relay function is identical to that of a relay valve serving the trailer air brake system as a remote controlled brake valve. Control (service) pressure from the towing vehicle is routed through the trailer service line and on to the relay portion of the valve. The emergency function of the valve automatically applies full trailer reservoir air pressure to the trailer chambers when the trailer supply pressure falls below a pre-determined minimum.

For ease of service, the valve features an "insert" cartridge consisting of the inlet/exhaust valve and emergency piston. Removal of the insert can usually be accomplished without line removal.

The RE-6 Relay Emergency Valve may be flanged or reservoir mounted, and identified, convenient porting locations of delivery, service, emergency (supply) and reservoir ports are provided.

OPERATION (STANDARD TRAILER INSTALLATION)**INITIAL CHARGING**

When the tractor is connected to a trailer and the service and emergency lines are opened (via the tractor protection system) the valve permits charging the trailer reservoir to approximately the same air pressure as that of the tractor reservoirs. Under initial charge conditions, the valve applies trailer service air chambers as the trailer emergency line is charged. The application is continued until the trailer supply (emergency) line is charged to 60-65 psi at which time the application is automatically released. The trailer reservoir continues to be charged to full operating pressure.

SERVICE APPLICATION

During normal, service braking operation, the valve serves as a relay valve, synchronizing tractor service (application) air pressure with trailer service (application) air pressure as the service foot brake valve on the tractor is operated. If the tractor is equipped with a trailer hand control (TC) valve, the trailer brakes can also be applied independently of the tractor brakes.

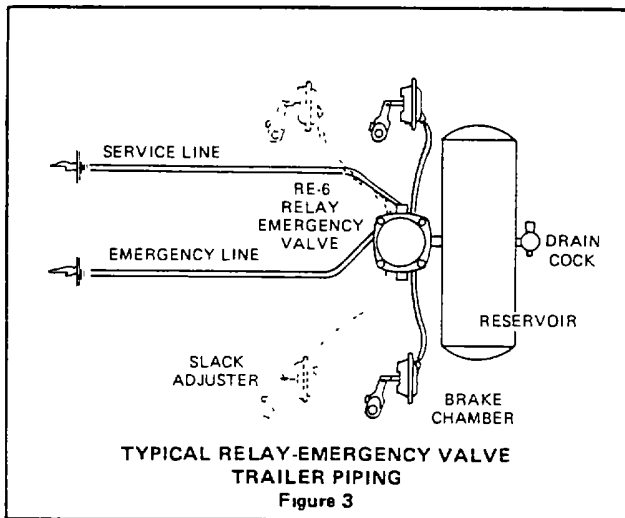

Figure 3.

EMERGENCY APPLICATION

(Trailer Air System charged to normal operating pressure) Venting the trailer supply line to atmosphere will cause the emergency portion of the Relay Emergency Valve to apply full trailer reservoir pressure to the trailer air chambers if the trailer supply line pressure is reduced to approximately 20 psi due to leakage or conditions other than above, a graduated trailer air chamber application will occur. The rate of this brake application will depend upon the rate of pressure loss in the supply line

If the trailer is not equipped with parking actuators (such as spring brakes), the trailer wheels should be blocked to prevent trailer movement, in the event reservoir pressure would be depleted.

TO RELEASE AN EMERGENCY APPLICATION

Recharge trailer air system or:

- A. For trailers equipped with standard brake chambers, block wheels and drain trailer reservoir.
- B. For trailers equipped with spring brake chambers, block wheels and mechanically release spring brake chambers via the mechanical release mechanism (for specific instructions, refer to manufacturers service literature.)

PREVENTIVE MAINTENANCE

Every 12 months, 100,000 miles or 3600 operating hours disassemble, clean metal parts in mineral spirits. Replace all rubber parts and any part worn or damaged. Check for proper operation before placing vehicle in service. To prevent entrance of foreign matter, it is recommended that filters be installed in the trailer supply and service hose couplings. Check periodically, and clean or replace as necessary.

OPERATING AND LEAKAGE TEST

Check tractor dash gauge against a test gauge known to be accurate prior to performing these tests. Connect tractor air lines to the trailer on which the valve is to be tested. Block wheels or otherwise hold both vehicles by a means other than air brakes during these tests.

1. Start these tests with no air pressure in the tractor or trailer system. Make certain trailer connection cut-out cocks are open if present. Build tractor air system to at least 50 P.S.I. Move tractor protection control valve to normal position. As trailer system starts to charge, trailer brakes should apply and then completely release as trailer supply line pressure reaches 60-65 P.S.I.
2. Fully charge tractor and trailer air brake system. Make several service brake applications and check for prompt braking response at all trailer wheels. With brakes released and system reservoir pressure stabilized at 100-120 psi with engine stopped, a two minute check should result in no more than a six pound pressure drop for the combination vehicle system. If this check indicates possible excessive leakage of valve, soap suds should be applied to the exhaust port to detect possible leakage of inlet valve and emergency piston O-Ring leakage. Leakage of a one inch soap bubble in not less than five seconds is permissible. No leakage is permissible at pipe plugs or fittings.
3. Make and hold a full service brake application with system reservoir pressure stabilized at 100-120 psi with engine stopped. A two minute check should result in no more than an eight (8) psi drop for the combination vehicle system. If this check indicates possible excessive leakage of valve, soap suds should be applied to cover to detect body O-Ring leakage and to exhaust port to detect exhaust valve and O-Ring leakage. A combined leakage as indicated by a one inch bubble in not less than three seconds is permissible. Release the service brake application.
4. With tractor and trailer air brake system fully charged, place the tractor protection control valve in the "emergency" position or close the emergency line cut-out cock on the tractor and uncouple the trailer emergency line coupling. Note that trailer brakes apply promptly. Check at the supply (emergency) line coupling at the front of the trailer for leakage. No leakage permitted. A leak detected at the supply (emergency) line coupling would indicate leaking check valve or piston O-Rings in the valve. Check at service line coupling at the front of the trailer. A leak at the service line coupling would indicate leaking relay piston O-Ring. Reconnect service and emergency lines and recharge tractor and trailer air brake system, noting that trailer

brakes release at a maximum of 65 psi trailer supply (emergency) line pressure as the trailer air brake system is recharged to full operating pressure.

5. With tractor and trailer air brake systems fully charged, stop engine. Reduce pressure by making a series of foot valve applications, and note that trailer brakes apply automatically at approximately 20 psi, tractor reservoir pressure or at the automatic emergency setting of the tractor protection equipment, if installed.

If the valve does not function as described, or if leakage is excessive, it is recommended that it be replaced with a new or remanufactured unit or repaired with genuine Bendix parts available at Bendix HVSG outlets.

REMOVING AND INSTALLING

REMOVING

1. Block trailer wheels.
2. Drain trailer system air reservoirs.
3. Identify and disconnect air lines from valve.
(Note: the emergency piston and valve assembly, generally referred to as the "insert" can be removed without line removal. To remove the insert, remove the exhaust cover and pull insert out.)
4. Remove mounting bolts, or unscrew from pipe nipple mount

INSTALLING

If valve will be flange mounted directly to steel, it is - recommended that a flange gasket be utilized to prevent electrolytic action between the unlike metals. If the valve is adapter or nipple mounted directly to a reservoir, it is recommended that "Never Seez" lubricant be applied to the threads before installation. This will prevent galling of the threads and make removal easier.

1. Clean and inspect all connecting line and hoses for cracks, deterioration or damage. Replace as necessary.
2. Mount valve securely
3. Connect all lines and hoses to valve

DISASSEMBLY (Ref. Figure 4)

1. Mark cover (1) and body (9) to assure proper positioning when assembling.
2. Remove cap screws (27), lockwashers (26) and exhaust cover (25).
3. Remove check valve (20) and check valve spring (21) and O-Rings (22 & 24). Remove spring (23).
4. Remove exhaust diaphragm screw (30), diaphragm (28), and washer (29) from exhaust cover.

5. Remove cap screws and lockwashers from cover (1)
6. Remove cover (1), relay piston (3) and piston return spring (5) (if so equipped). Remove piston O-Ring (2). Remove O-Ring (8) from body bore.
7. Remove exhaust valve seat (4) from piston.
8. Remove sealing ring (6) from body
9. Remove filter assembly (7) from emergency (supply) port. (Note: If new insert is to be installed, omit steps 10-15.)
10. Apply downward pressure on emergency piston (11) and remove emergency piston and inlet/exhaust valve assembly.
11. With Tru-Arc pliers, remove large valve retainer (19) from bottom of emergency piston assembly.
12. Push through small end of emergency piston (11) with finger and remove inlet/exhaust valve assembly
13. Remove emergency piston O-Ring (10) and O-Ring (15) from inlet/exhaust valve assembly.
14. Remove retaining ring (18) from inlet/exhaust valve assembly.
15. Remove valve guide (17), spring (14), retainer (13) and valve guide O-Ring (16).

CLEANING AND INSPECTION OF PARTS

Wash all metal parts in mineral spirits.

Wipe rubber parts dry.

Inspect all parts for wear, damage or deterioration.

Clean or replace all filters.

Replace all rubber parts and any other part not considered serviceable by these inspections.

ASSEMBLY (Ref. Figure 4)

Note All torque specified are assembly torque and can be expected to fall off after assembly. Do not re-torque after initial assembly torque fall. For assembly, hand wrenches are recommended.

Prior to assembly, lubricate all O-Rings and mating surfaces with Dow-Corning 55-M pneumatic grease (Bendix Pc. No. 291126). (Note: If new insert is installed, omit steps 1-6.)

1. Install O-Ring (16) in valve guide (17)
2. Install valve retainer (13), spring (14) and valve guide (17) to inlet/exhaust valve.
3. Compress spring by holding valve guide and install retaining ring (19). Make certain the ring is properly installed in groove.
4. Install O-Ring (15) on valve guide.
5. Install inlet/exhaust valve assembly into emergency piston. With Tru-Arc pliers, install valve retainer (19) making certain it is in groove.

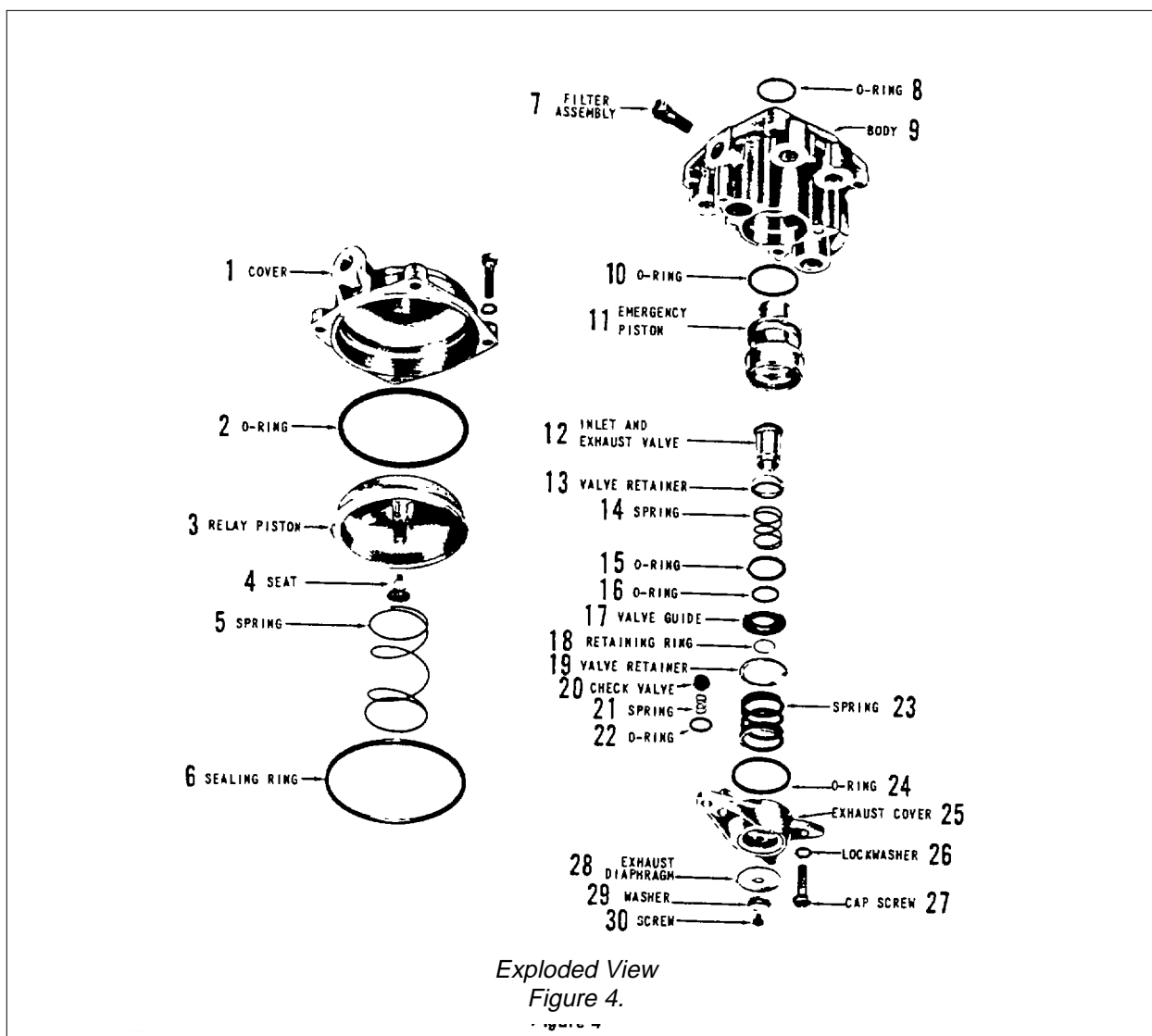

6. Install emergency piston O-Ring (10).
7. Install filter assembly (7) in emergency (supply) port.
8. Install seat (4) on piston.
9. Install O-Ring (2) on piston.
10. Install O-Ring (8) in upper bore of body.
11. Install sealing ring (6) in groove of body.
12. Install relay piston (3) in cover. (Boss on cover will fit bore in piston.)
13. If so equipped, install piston return spring (5)
14. Install cover to body, make certain cover is in previously marked position. Torque cap screws to approximately 100 inch pounds.
15. Install emergency piston and inlet/exhaust valve insert in body.
16. Install O-Ring (24) in body.
17. Install spring (23) in body.
18. Install exhaust diaphragm (28), washer (29) and screw (30).
19. Install small O-Ring (22) in exhaust cover.
20. Install check valve (20) and spring (21). Spring will fit in groove in cover.
21. Install exhaust cover (25) install cap screws and lockwashers, torque to approximately 100 inch pounds.
22. Check valve as outlined in "Operating and Leakage" check sections before placing vehicle in service.

RELAY EMERGENCY VALVE TYPE RE-6

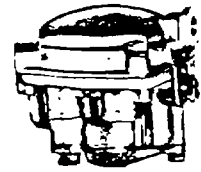

Relay Emergency valves are generally used on pre- "121" trailers and in some special cases on off-the-road equipment. Like the relay valve, the relay emergency valve is a high capacity, air operated, graduating control valve. In addition it incorporates an emergency feature which will automatically apply the service brakes in the event that supply air pressure is lost.

The RE-1, RE-4 and RE-6 differ primarily in design but will easily interchange with one another as well as competitive valves.

Relay emergency valves can be mounted either directly to the reservoir or remote from it. For installation and maintenance information, see Instruction and Service Data Sheet, SD-56.

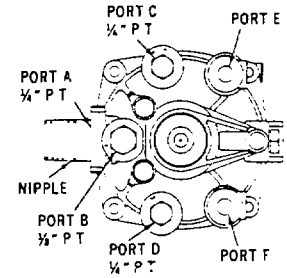
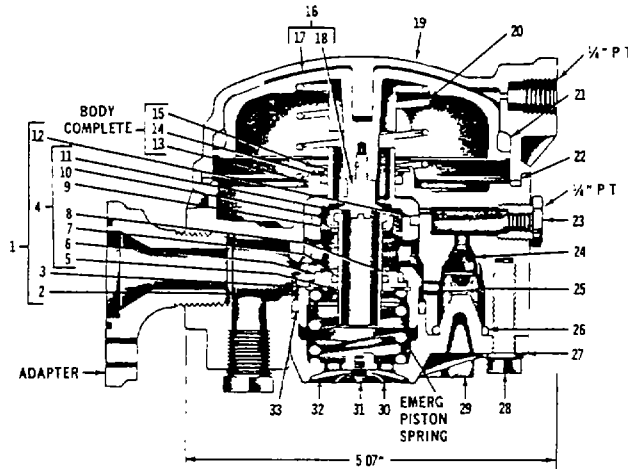

NOTE J
VALVE 281869 Has
Two (2) 1/4" P T
Tees In E & F Ports

NOTE K
BODY COMPLETE #281712 Uses
BODY #246120 & Has 3/8" P T
In E & F Ports
BODY COMPLETE #281673 Uses
BODY #246077 & Has 1/4" P T
In E & F Ports

The Following Parts Are Packaged With Valve

	REQUIRED	DESCRIPTION	PC NO
NOTE G	2	1/4" Pipe Plug	230111
	3	3/8" Pipe Plug	238807
NOTE H	2	1/4" Pipe Plug	230111
	2	3/8"-1/4" Reducer Bushing	212862

MAINTENANCE KIT FOR COMPLETE VALVE IS 282812

MAINTENANCE KIT FOR EMERG PISTON & VALVE ASSY (INSERT) IS 282813

SERVICE INSERT FOR VALVE IS 282814

NOTE L—High Press RE-6 Valves

RE-6 PC NO	INITIAL EMERG APPL PRESS (PSI)	MAX EMERG REL PRESS (PSI)	SYSTEM PRESS (PSI)
283295*	50 ± 5	95	125
284280	65 ± 5	110	135

*This valve supersedes OBS RE-4 Valve, 279986

RE-6 RELAY EMERG VALVE O E PC NO	FOR SERVICE OR REMFR EXCH USE PC NO	BODY COMPLETE PC NO	EMERG PISTON SPRING PC NO	REFERENCE DETAILS					
				A	B	C	D	E	F
				ADAPTER PC NO	NIPPLE PC NO	PIPE PLUG PC NO	PIPE PLUG PC NO	PIPE PLUG PC NO	PIPE PLUG PC NO
G281672	281865	281673	246084	—	—	238807	—	—	—
281711	281865	281712	246084	—	—	238807	—	—	—
281860	281865	281673	246084	—	—	238807	—	—	—
281851	281865	281673	246084	—	—	238807	—	—	—
281853	281865	281673	246084	241872	—	238807	—	—	—
281864	281865	281673	246084	*241871	—	—	—	—	—
H281865	281865	281712	246084	—	—	—	—	—	—
281866	281865	281673	246084	—	241446	238807	—	—	—
281868	281865	281673	246084	*241871	—	—	230111	230111	—
281869	281865	281712	246084	—	—	238807	—	Note J	Note J
281870	281865	281712	246084	*241871	—	—	—	—	—
283034	281865	281673	246084	243505	—	—	—	—	—
L283295	283295	281673	249926	—	—	238807	—	—	—
284103	281865	281673	246084	—	—	—	—	—	—
G284123	281865	281673	246084	—	—	—	—	—	—
L284280	284280	281673	249843	—	—	238807	—	—	—
285553	281865	281712	246084	*241871	—	—	—	—	—

*Adapter 241871 Has Center Hole Closed

NO	PC NO	QUAN	DESCRIPTION	NO	PC NO	QUAN	DESCRIPTION
1	281674	1	Emerg Piston & Vaive Assy	16	281676	1	Relay Piston Assy
2	246079	1	Emergency Piston	17	243974	1	Relay Piston
3	236621	1	Retaining Ring	18	246087	1	Exhaust Valve Seat
4	281675	1	Inlet & Exh Valve Assy	19	243972	1	Cover
5	246225	1	Retaining Ring	20	243971	1	Piston Return Spring
6	240337	1	O-Ring, 1 1/4" O D	21	243973	1	Rel Piston O-Ring, 4 1/8" O D
7	235063	1	O-Ring, 1/8" O D	22	245290	1	Sealing Ring, 4.387" O D
8	246224	1	Valve Guide	23	246895	1	Filter (Includes Bushing 246915)
9	246081	1	Valve Spring	24	238837	1	Check Valve
10	246223	1	Valve Retainer	25	238954	1	Check Valve Spring
11	248188	1	Inlet & Exh Valve Assy	26	214745	1	Exh Cover O-Ring, 1/4" O D
12	238237	1	O-Ring, 1 1/2" O D	27	237648	7	1/16" Lockwasher
See Schedule		1	Body Complete	28	203821	7	3/16"-18 hex Hd Cap Screw
13 See Note K		1	Body	29	246085	1	Exhaust Cover
14	236649	1	O-Ring, 1 1/4" O D	30	239943	1	Diaphragm Washer
15	246078	1	Special Washer	31	242228	1	#10-24 Pan Hd Screw
				32	246086	1	Exhaust Diaphragm
				33	246083	1	Exh. Cover O-Ring, 1 1/8" O D

APPENDIX A

MAINTENANCE ALLOCATION CHART

CO/PRESSOR, RECIPROCATING DIESEL ENGINE DRIVEN

20 CFM, 3200 PSI

Section I.

INTRODUCTION

A-1. GENERAL.

a. This section provides a general explanation of all maintenance and repair functions authorized at various maintenance levels.

b. Section II designates overall responsibility for the performance of maintenance functions on the identified end item or component and the work measurement time required to perform the functions by the designated maintenance level. The implementation of the maintenance functions upon the end item or component will be consistent with the assigned maintenance functions.

c. Section III lists the tools and test equipment required for each maintenance function as referenced from Section II.

d. Section IV contains supplemental instructions or explanatory notes for a particular maintenance function.

A-2. EXPLANATION OF COLUMNS IN SECTION II.

a. Group Number, Column (1). A number is assigned to each group in a top down breakdown sequence. The applicable groups are listed in the MAC in disassembly sequence beginning with the first group removed.

b. Assembly Group, Column (2). This column contains a brief description of the components of each numerical group.

c. Maintenance Functions, Column (3). This column lists the functions to be performed on the items listed in Column 2. The lowest maintenance level authorized to perform these functions is indicated by a symbol in the appropriate column. The symbol designators for the various maintenance levels are as follows:

C--Operator or crew.

O--Organizational Maintenance.

F--Direct Support Maintenance.

H--General Support Maintenance.

D--Depot Maintenance.

The maintenance functions are defined as follows:

Change 1 A-1

- (1) Inspect. To determine serviceability of an item by comparing its physical, mechanical, and electrical characteristics with established standards through examination.
- (2) Test. To verify serviceability and detect incipient failure by measuring the mechanical or electrical characteristics of an item and comparing those characteristics with prescribed standards.
- (3) Service. Operations required periodically to keep an item in proper operating condition, i.e., to clean, to preserve, to drain, to paint, or to replenish fuel lubricants, hydraulic fluids, or compressed air supplies.
- (4) Adjust. To maintain within prescribed limits, by bringing into proper or exact position, or by setting the operating characteristics to specified parameters.
- (5) Align. To adjust specified variable elements of an item to bring about optimum or desired performance.
- (6) Calibrate. To determine and cause corrections to be made or to be adjusted on instructions or test measuring and diagnostic equipment used in precision measurement. Consists of comparison of two instruments, one of which is a certified standard of known accuracy, to detect and adjust any discrepancy in the accuracy of the instrument being compared.
- (7) Install. The act of emplacing, seating, or fixing into position an item, part, or module (component or assembly) in a manner to allow the proper functioning of an equipment or system.
- (8) Replace. The act of substituting a serviceable like type part, subassembly, or module (component or assembly) for an unserviceable counterpart.
- (9) Repair. The application of maintenance services (inspect, test, service, adjust, align, calibrate, or replace) or other maintenance actions (welding, grinding, riveting, straightening, facing, re-machining or resurfacing) to restore serviceability to an item by correcting specific damage, fault, malfunction, or failure in a part, subassembly, module (component or assembly), end item, or system.
- (10) Overhaul. That maintenance effort (service/action) necessary to restore an item to a completely serviceable/operational condition as prescribed by maintenance standards (i.e., DMWR) in appropriate technical publications. Overhaul is normally the highest degree of maintenance performed by the Army. Overhaul does not normally return an item to a like-new condition.
- (11) Rebuild. Consists of those services/actions necessary for the restoration of unserviceable equipment to a like-new condition in accordance with original manufacturing standards. Rebuild is the highest degree of materiel maintenance applied to Army equipment. The rebuild operation includes the act or returning to zero those age measurements (hours/miles, etc.) considered in classifying Army equipment/components.

d. Maintenance Level, Column (4). This column is made up of sub-columns for each category of maintenance. Work time figures are listed in these sub-columns for the lowest level of maintenance authorized to perform the function listed in column 3. These figures (shown directly below the symbol) indicate the average active time required to perform the maintenance function at the indicated category of maintenance under typical field operating condition.

e. Tools and Equipment, Column (5). This column is provided for referencing by code, the special tools and test equipment (Sec. III) required to perform the maintenance functions (Sec. II).

f. Remarks, Column (6). This column shall contain a letter code in alphabetic order which shall be keyed to the remarks contained in Section IV.

A-3. EXPLANATION OF COLUMNS IN SECTION III.

a. Reference Code. This column consists of an Arabic number listed in sequence from column (5) of Section II. The number references the special tools and test equipment requirements.

b. Maintenance level. This column shows the lowest level of maintenance authorized to use the special tools or test equipment.

c. Nomenclature. This column lists the name or identification of the tools or test equipment.

d. National/NATO Stock Number. This column is provided for the NSN of special tools and test equipment listed in the nomenclature column.

e. Tool Number. This column lists the manufacturer's code and part number of tools and test equipment.

A-4. EXPLANATION OF COLUMNS IN SECTION IV.

a. Reference Code. This column consists of a letter code in alphabetic order which is keyed to column 6 of Section II.

b. Remarks. This column lists information pertinent to the maintenance function being performed, as indicated on the MAC, Section II.

Change 1 A-3

Section II. MAINTENANCE ALLOCATION CHART

NONENCLATURE OF END ITEMS
 Compressor, Reciprocating, Diesel Engine Driven 20 CFM, 3200 PSI
 NSN 4310-01-044-2301

(1) GROUP NUMBER	(2) COMPONENT ASSEMBLY	(3) MAINTENANCE FUNCTION	(4) MAINTENANCE LEVEL					(5) TOOLS AND EQUIPMENT	(6) REMARKS
			C	O	F	H	D		
01	Air Compressor Ass'y - DED 20 CFM 3200 PSI	Service	X						
		Replace		X					
		Overhaul		X					
02	Air Compressor Ass'y	Service	X						
		Repair		X					
		Replace		X					
		Overhaul		X					
03	Air Intake Ass'y	Inspect	X						
		Service	X						
		Repair		X					
		Replace		X					
0301	Filter Element	Replace		X					
04	Cylinder Head Ass'y	Inspect		X					
		Replace		X					
		Repair		X					
0401	Valves, (Inlet & Inspect Outlet)		X						
		Service		X					
		Test		X					
		Replace		X					
0402	Valves, Safety (All Stages)	Test	X						
		Replace		X					
05	Cylinder & Crank								
Change 1 A-4									

Section II. MAINTENANCE ALLOCATION CHART

(1) GROUP NUMBER	(2) COMPONENT ASSEMBLY	(3) MAINTENANCE FUNCTION	(4) MAINTENANCE LEVEL					(5) TOOLS AND EQUIPMENT	(6) REMARKS
			C	O	F	H	D		
0501	Case Cylinder	Inspect		X					
		Repair		X					
		Replace		X					
0502	Piston & Con Rd Ass'y	Inspect		X					
		Repair		X					
		Replace		X					
0503	Piston Rings	Inspect		X					
		Replace		X					
0504	Bearing & Bush- ings	Inspect		X					
		Replace		X					
0505	Crankshaft Ass'y	Inspect		X					
		Replace		X					
0506	Bearing & Carriers	Inspect		X					
		Replace		X					
0507	Oil Pump & Drive	Inspect		X					
		Service		X					
		Replace		X					
		Repair		X					
0508	Oil Pump Regulator	Inspect		X					
		Adjust		X					
		Replace		X					
0508	Oil Fill Tube & Dipstick	Inspect	X						
		Service	X						
Change 1 A-5									

Section II. MAINTENANCE ALLOCATION CHART

(1) GROUP NUMBER	(2) COMPONENT ASSEMBLY	(3) MAINTENANCE FUNCTION	(4) MAINTENANCE LEVEL					(5) TOOLS AND EQUIPMENT	(6) REMARKS
			C	O	F	H	D		
0509	Gasket, Hose & Gap	Replace		X					
06	Safety Valves	Inspect	X						
		Replace		X					
07	Inter-cooler Ass'y	Inspect		X					
		Replace		X					
08	Condensation Drains	Inspect	X						
09	Intermediate Filter	Inspect	X						
		Service	X						
0901	Element	Replace	X						
1000	Oil & Water Separator	Service	X						
		Replace		X					
1100	Purifier	Inspect	X						
		Service	X						
1101	Cartridge	Replace	X						
1200	Drying Filter	Inspect	X						
		Service	X						
1300	Pressure Maintaining Valve	Inspect	X						
		Replace		X					
1400	Centrifugal Clutch	Inspect		X					
		Service		X					
		Repair		X					
		Replace		X					
		Change 1 A-6							

Section II. MAINTENANCE ALLOCATION CHART

(1) GROUP NUMBER	(2) COMPONENT ASSEMBLY	(3) MAINTENANCE FUNCTION	(4) MAINTENANCE LEVEL					(5) TOOLS AND EQUIPMENT	(6) REMARKS
			C	O	F	H	D		
1500	Pressure Gauges	Inspect	X						
		Test		X					
		Replace		X					
1600	Filling Hoses & Inspect Filing Valves	Inspect	X						
		Service	X						
		Test		X					
		Repair		X					
		Replace		X					
1700	Fan & Cover Ass'y	Inspect		X					
		Service		X					
1701	Fan	Replace		X					
1702	Shroud	Repair		X					
		Replace		X					
1800	Hourmeter	Inspect	X						
		Replace		X					
1900	Base Frame	Inspect	X						
		Service	X						
		Repair		X					
2000	Engine, DSL 25 HP	Service	X						
		Repair		X					
		Replace		X					
		Overhaul		X					
2100	Cylinder Head Ass'y	Inspect		X					
Change 1 A-7									

Section II. MAINTENANCE ALLOCATION CHART

(1) GROUP NUMBER	(2) COMPONENT ASSEMBLY	(3) MAINTENANCE FUNCTION	(4) MAINTENANCE LEVEL					(5) TOOLS AND EQUIPMENT	(6) REMARKS
			C	O	F	H	D		
2101	Valves Int & Exh	Replace		X					
		Repair		X					
		Inspect		X					
		Adjust		X					
		Replace		X					
2102	Retainers, Springs & Guides	Repair		X					
		Inspect		X					
		Test		X					
2103	Rocker Ass'y	Replace		X					
		Inspect		X					
		Replace		X					
2200	Cyl Block & Crankcase Ass'y	Repair		X					
		Inspect		X					
		Replace		X					
2201	Crankcase Ass'y	Inspect		X					
		Replace		X					
2202	Piston & Con/rods	Inspect		X					
		Repair		X					
		Replace		X					
2203	Bearings, Rings & Pins	Inspect		X					
		Replace		X					
2204	Push Rods & Cam Followers	Inspect		X					
		Replace		X					
		Change 1 A-8							

Section II. MAINTENANCE ALLOCATION CHART

(1) GROUP NUMBER	(2) COMPONENT ASSEMBLY	(3) MAINTENANCE FUNCTION	(4) MAINTENANCE LEVEL					(5) TOOLS AND EQUIPMENT	(6) REMARKS
			C	O	F	H	D		
2205	Crankshaft & Bearing	Inspect		X					
		Replace		X					
2206	Gear Train Ass'y	Inspect		X					
		Replace		X					
2207	Crankshaft	Inspect		X					
		Replace		X					
2208	Bearings & Seals	Inspect		X					
		Replace		X					
2209	Dipstick	Inspect	X						
		Replace	X						
2210	Flywheel Ass'y	Inspect		X					
		Replace		X					
		Repair		X					
2211	Ring Gear	Service		X					
2300	Lubrication System			X					
2301	Lube Oil Pump	Inspect		X					
2302	Filter Ass'y	Inspect	X						
		Service	X						
		Replace		X					
2400	Exhaust System			X					
2401	Muffler	Inspect	X						
		Replace		X					
Change 1 A-9									

Section II. MAINTENANCE ALLOCATION CHART

(1) GROUP NUMBER	(2) COMPONENT ASSEMBLY	(3) MAINTENANCE FUNCTION	(4) MAINTENANCE LEVEL					(5) TOOLS AND EQUIPMENT	(6) REMARKS
			C	O	F	H	D		
2402	Manifold	Service		X					
		Replace		X					
2500	Fuel System	Service	X						
		Test	X						
		Adjust		X					
		Replace		X					
		Repair		X					
2501	Injection Pump Ass'y	Service		X					
		Test		X					
		Replace		X					
		Repair		X					
2502	Filter Ass'y	Inspect	X						
2503	Cartridge	Replace	X						
2504	Lines & Fittings	Service	X						
		Replace		X					
2600	Fuel Tank	Service	X						
		Replace		X					
2700	Air Intake System	Inspect	X						
2701	Air Cleaner	Service	X						
		Replace		X					
2702	Manifold	Service		X					
		Replace		X					
2800	Throttle Controls	Inspect	X						
Change 1 A-10									

Section II. MAINTENANCE ALLOCATION CHART

(1) GROUP NUMBER	(2) COMPONENT ASSEMBLY	(3) MAINTENANCE FUNCTION	(4) MAINTENANCE LEVEL					(5) TOOLS AND EQUIPMENT	(6) REMARKS
			C	O	F	H	D		
2900	Pulley & V-Belt	Service	X						
		Adjust		X					
		Replace		X					
		Repair		X					
2901	Pulley	Inspect	X						
2902	V-Belt	Replace		X					
		Inspect	X						
		Adjust	X						
3000	Blower & Cooling	Replace		X					
		Inspect	X						
		Service	X						
		Repair		X					
3100	Electrical System Generator (or Alternator)	Replace		X					
		Test		X					
		Service	X						
		Replace		X					
3101	Battery	Repair		X					
		Inspect	X						
		Service	X						
3103	Starting Switch	Test		X					
		Replace		X					
		Inspect	X						
Change 1 A-11									

Section II. MAINTENANCE ALLOCATION CHART

(1) GROUP NUMBER	(2) COMPONENT ASSEMBLY	(3) MAINTENANCE FUNCTION	(4) MAINTENANCE LEVEL					(5) TOOLS AND EQUIPMENT	(6) REMARKS
			C	O	F	H	D		
3200	Clutch/Coupling	Replace		X					
		Inspect		X					
		Repair		X					
		Replace		X					
3300	Starting Aid	Inspect	X						
		Service	X						
		Replace	X						
3400	Instruments Gages (Oil temp and press)	Inspect	X						
		Replace		X					
3500	Starter	Inspect		X					
		Repair		X					
		Replace		X					
		Change 1 A-12							

**SECTION III. TOOL AND TEST EQUIPMENT
REQUIREMENTS**

(1) Ref. Code	(2) Maint. Level	(3) Nomenclature	(4) National/NATO Stock Number	(5) Tool Number
1	0	Wrench, Strap	5120-00-262-8491	GGG-W-651 (81348)
2	0	Installation Sleeve Rear Pump Cover & Seal	5120-01-059-7728	67939 (16004)
3	0	Gauge, Feeler Class 1 (81348)	5210-00-221-1986	GGG-G-17 Type VIII
4	0	Hydrometer, Battery Style B (81348)	6630-00-171-5126	GG-T-258, Class 1
5	0	Puller, Gear 3 Jaw (81348)	5120-00-516-3120	GGG-P-481 Size 3
6	0	Compressor, Piston Ring	5120-00-250-6055	GGG-L-350 (81348)
7	0	Wrench, Torque 0-2, 400 inch pounds	5120-00-910-3350	GGG-W-686 (81348)
8	0	Cleaner, Ultrasonic	4940-00-164-8997	7 (24311)
9	0	Hone, Cylinder, Portable	5130-00-222-3905	JN-95 (58436)
10	0	Hone, Cylinder, Electric (81348)	5130-00-540-0152	MIL-C-82069
11	0	Punch, Drive Pin	5120-00-595-9485	PPC-714A (55719)
12	0	Pliers, Snap Ring	5120-01-155-8359	PR-7 (55719)
13	0	Gun, Heat	4940-00-357-1369	Model HG (61330)
14	0	Tool, Clutch Aligning	5120-01-053-3118	68247 (16004)
15	0	Adjustment Tool, Clutch	5120-01-053-6122	68959 (16004)
16	0	Multimeter, Digital	6625-00-322-8715	8000A (8N240)
17	0	Growler, Armature	6625-00-093-7797	MT-326A (55719)
18	0	Test Stand, High Pressure Air End	4310-01-054-4780	83740 (16004)
19	0	Spreader, Piston Ring		PRS-8 (55719)
20	0	Grove Cleaner, Piston Ring		RC-510 (55719)

Change 1 A-13

**SECTIN III. TOOL AND TEST EQUIPMENT
REQUIREMENTS**

(1) Ref. Code	(2) Maint. Level	(3) Nomenclature	(4) National/NATO Stock Number	(5) Tool Number
21	0	Cleaning Kit, Nozzle		KDEP-2900 (Robert Bosch)
22	0	Tool Kit, Special Engine Consisting of: Torque Wrench 0-14 KPM Multi-Tooth Socket 54 x M8K Allen Insert 10mm Allen Insert 6mm Allen Insert 6mm w/pin Allen Insert 8mm Clamp, Fuel Pipe Adjusting Tool, Injector Pump, w/Timing Gage Pin Timing Gauge Socket Wrench, Fuel Device Revolution Counter Insert, Revolution Counter Tester, Injection Pump and Valve Oil Pressure Gage 0.6KP Spring Set, Cam Followers (1 set = 4 pcs) Clamp, Timing Gauge Measuring Bridge for Bumping Clearance Valve Seat Reamer 45° 52.5mm dia.		84343 (16004) 84344 (16004) 84345 (16004) 82408 (16004) 69615 (16004) 84346 (16004) 69605 (16004) 84347 (16004) 82411 (16004) 69601 (16004) 69597 (16004) 84348 (16004) 84349 (16004) 69600 (16004) 84350 (16004) 84351 (16004) 69598 (16004) 69599 (16004) 84352 (16004)

**SECTIN III. TOOL AND TEST EQUIPMENT
REQUIREMENTS**

(1) Ref. Code	(2) Maint. Level	(3) Nomenclature	(4) National/NATO Stock Number	(5) Tool Number
		Guide Pin 9mm dia.		82413 (16004)
		Handle, Valve Seat Reamer		69604 (16004)
		Valve Seat Reamer 45°, 47.5mm dia.		84353 (16004)
		Handle, Valve Lapping		84354 (16004)
		Punch, Valve Guide, 9mm		82406 (16004)
		Mounting Punch, Valve Stem Seal Cap		84355 (16004)
		Pliers, Piston Ring		84356 (16004)
		Strap, Piston Rings		84357 (16004)
		Punch, Camshaft Bearing		84358 (16004)
		Punch, Camshaft Bearing		84359 (16004)
		Extractor, Timing Cover		84360 (16004)
		Extractor, Crankshaft Gear		84361 (16004)
		Punch, Flange Oil Seal		84362 (16004)
		Mounting Tool, Main Bearing		84363 (16004)
		Mounting Tool, Main Bearing		84364 (16004)
		Auxiliary Bushing Governor Cover Mounting (Crankshaft)		84373 (16004)
		Bushing, Governor Cover Mounting (Camshaft)		84365 (16004)
		Punch, Blower Assembly		84366 (16004)
		Bolt, Blower Assembly		84367 (16004)
		Bolt, Blower Assembly		84368 (16004)
		Reamer, Valve Guide, 9mm		84369 (16004)

**SECTION III. TOOL AND TEST EQUIPMENT
REQUIREMENTS**

(1) Ref. Code	(2) Maint. Level	(3) Nomenclature	(4) National/NATO Stock Number	(5) Tool Number
		Clamping Yoke, Cylinder		84374 (16004)
		Adjusting Gauge		84375 (16004)
		Riveting Tool		84376 (16004)
		Change 1 A-16		

PRELIMINARY
20 CFM COMPRESSOR ASSEMBLY 4310-01-044-2301

Section IV.

MAINTENANCE ALLOCATION CHART	
RERERENCE CODE	REMARKS
	NONE Change 1 A-17/(A-18 blank)

**APPENDIX B
REPLACEMENT PARTS UST
COMPRESSOR, RECIPROCATING, DIESEL ENGINE DRIVEN,
20 CFM, 3200 PSI**

Figure No.	Item Number	Part Number	FSCM	NSN	Description	Qty
8-2	29	574600	90005	4330-00-008-8820	Filter Assembly 10 Micron	2
		MS39171-15	96906			
	12	8890	16004	4730-00-068-6616	Elbow, Pipe Tube	2
8-8	8	65168	16004	6685-00-082-1939	Gage, Oil Pressure	1
8-8	18	SW4001	19728	2920-00-132-8368	Switch, Start	1
8-12	6	1B	24161	4720-00-151-6717	Hose, Crankcase	1
8-8	11	2550-108	09393	6620-00-169-1178	Gage, Pressure, Engine Oil	1
8-12	30	61076	16004	4720-00-180-6263	Hose Ass'y, Oil Pump	1
8-11	28	46163	16004	4720-00-184-7619	Hose Ass'y, Compressor Oil	1
8-8	2	48271	16004	6625-00-189-6970	Gage, Ammeter	1
8-3	4	AN6227-36	88044	5330-00-196-5322	Packing, Prefomed	6
		AN123885	88044			
		24798	16004	5330-00-291-7353	Packing, Preformed	6
8-4	15	C-1-AC	82990	4440-00-355-7755	Cartridge, Sweetner, Air	2
		CS4440-0012	16236			
		C0-6	82990	4440-00-357-5505	Cartridge, Dehydrator	2
8-8	21	75903	13445	5930-00-482-2103	Switch, Master	1
		AN6235-2A	88044	4330-00-542-2060	Element, Filter 10 Micron	2
8-4	15	MA-2	82990	4440-00-547-3747	Cartridge, Oxypurifier # 1&2	4
8-4	15	C-1-13X	82990	4460-00-716-6271	Cartridge, Oil Vapor	2
8-21	5	28727	16004	4710-00-739-8869	Filter, Trap	1
		3-6	30780	5330-00-740-6058	Hose Ass'y, Oil Sump	1
8-3	3	MF-1-5857	82990	4330-00-861-6771	Element, Filter	2
8-3		MF1-5850	82990	4310-00-873-1757	Filter Ass'y, Mechanical	1
		B27854	16004			
		27854	16004	2990-00-896-2166	Control Assembly	1
		M179-224	54418			
		70844	16004	4730-00-908-3191	Clamp, Hose	2
		MS35842-15	96906			

Change 1 B-1

Figure No.	Item Number	Part Number	FSCM	NSN	Description	Qty
		61054	16004	4730-00-908-6293	Clamp, Hose	2
		B298	12658			
8-12	44	82042	16004	2940-00-962-4117	Filter Element	2
		PER-1	81321	2940-00-986-0276	Filter, Oil, Compressor	2
		MF-1-5817	82990	4310-01-006-5807	Element, Mechanical Filter	2
8-21	5	28726	16004	4730-01-008-2968	Screen, Filter	2
8-23	4	66449	16004	4820-01-009-9223	Valve Ass'y	1
8-21	5	28725	16004	4730-01-015-2733	Screw, Filter	2
8-12	24	38029	16004	4720-01-036-7468	Hose Ass'y, Oil Sump	1
8-12	27	61075	16004	4720-01-036-7469	Hose Ass'y, Oil Pump	1
8-12	20	AG1073	16004	4720-01-037-4321	Hose Ass'y	1
8-23	6	66489	16004	4710-01-037-7766	Strainer Ass'y	2
8-23	7	66490	16004	4730-01-037-9115	Filter, Cap	1
8-8	1	60135	16004	6645-01-048-3014	Gage, Hour Meter	1
8-9	9	66377	16004	4820-01-050-0726	Nut, Cap, Disc	1
8-9	8	65361	16004	4820-01-052-5267	Base, Rupture Disc	1
8-13	4	27248	16004	4310-01-059-7748	Element, Air Filter, Compressor	2
8-37	1	82266	16004	2910-01-099-3425	Filter Ass'y Fuel	2
8-30	70	82277	16004	4810-01-099-6081	Valve, Solenoid	1
		82042	16004	2940-01-100-3411	Filter, Engine Oil	2
		M83461/1-332	81349	5330-01-118-2080	Packing, Preformed	6
		M83461/1-331	81349	5330-01-123-3303	Packing, Preformed	6
		84949	16004		Repair Kit, Compressor Overhaul	1
		84805	16004		Kit Repair, First Stage Valve	1
		84806	16004		Kit Repair, First Stage Cycle Group	1
		66495	16004		Kit Repair, Second Stage Valve	1
		68510	16004		Kit Repair, Second Stage Cycle Group	1
		66492	16004		Kit Repair, Third Stage Valve	1
		68511	16004		Kit Repair, Third Stage Cycle Group	1

Change 1 B-2

Figure No.	Item Number	Part Number	FSCM	NSN	Description	Qty	
		66493	16004		Kit Repair, Fourth Stage Valve	1	
		68512	16004		Repair Kit, Fourth Stage Cycle Group	1	
		65882	16004		Repair Kit, Bleed Valve Ass'y	1	
		65883	16004		Repair Kit, Bleed Valve Ass'y	1	
		65378	16004		Repair Kit, Drain Valve	1	
			Change 1 B-3/(B-4 blank)				

By Order of the Secretary of the Army:

Official:

DONALD J. DELANDRO
Brigadier General, United States Army
The Adjutant General

JOHN H. WICKHAM, JR.
General, United States Army
Chief of Staff

DISTRIBUTION:

To be distributed in accordance with DA Form 12-25D, Operator and Organizational Maintenance requirements for Marine Equipment A11.

* U.S. GOVERNMENT PRINTING OFFICE: 1994 0 - 300-421 (00171)

The Metric System and Equivalents

Linear Measure

1 centimeter = 10 millimeters = .39 inch
 1 decimeter = 10 centimeters = 3.94 inches
 1 meter = 10 decimeters = 39.37 inches
 1 dekameter = 10 meters = 32.8 feet
 1 hectometer = 10 dekameters = 328.08 feet
 1 kilometer = 10 hectometers = 3,280.8 feet

Weights

1 centigram = 10 milligrams = .15 grain
 1 decigram = 10 centigrams = 1.54 grains
 1 gram = 10 decigrams = .035 ounce
 1 dekagram = 10 grams = .35 ounce
 1 hectogram = 10 dekagrams = 3.52 ounces
 1 kilogram = 10 hectograms = 2.2 pounds
 1 quintal = 100 kilograms = 220.46 pounds
 1 metric ton = 10 quintals = 1.1 short tons

Liquid Measure

1 centiliter = 10 milliliters = .34 fl. ounce
 1 deciliter = 10 centiliters = 3.38 fl. ounces
 1 liter = 10 deciliters = 33.81 fl. ounces
 1 dekaliter = 10 liters = 2.64 gallons
 1 hectoliter = 10 dekaliters = 26.42 gallons
 1 kiloliter = 10 hectoliters = 264.18 gallons

Square Measure

1 sq. centimeter = 100 sq. millimeters = .155 sq. inch
 1 sq. decimeter = 100 sq. centimeters = 15.5 sq. inches
 1 sq. meter (centare) = 100 sq. decimeters = 10.76 sq. feet
 1 sq. dekameter (are) = 100 sq. meters = 1,076.4 sq. feet
 1 sq. hectometer (hectare) = 100 sq. dekameters = 2.47 acres
 1 sq. kilometer = 100 sq. hectometers = .386 sq. mile

Cubic Measure

1 cu. centimeter = 1000 cu. millimeters = .06 cu. inch
 1 cu. decimeter = 1000 cu. centimeters = 61.02 cu. inches
 1 cu. meter = 1000 cu. decimeters = 35.31 cu. feet

Approximate Conversion Factors

<i>To change</i>	<i>To</i>	<i>Multiply by</i>	<i>To change</i>	<i>To</i>	<i>Multiply by</i>
inches	centimeters	2.540	ounce-inches	newton-meters	.007062
feet	meters	.305	centimeters	inches	.394
yards	meters	.914	meters	feet	3.280
miles	kilometers	1.609	meters	yards	1.094
square inches	square centimeters	6.451	kilometers	miles	.621
square feet	square meters	.093	square centimeters	square inches	.155
square yards	square meters	.836	square meters	square feet	10.764
square miles	square kilometers	2.590	square meters	square yards	1.196
acres	square hectometers	.405	square kilometers	square miles	.386
cubic feet	cubic meters	.028	square hectometers	acres	2.471
cubic yards	cubic meters	.765	cubic meters	cubic feet	35.315
fluid ounces	milliliters	29.573	cubic meters	cubic yards	1.308
pints	liters	.473	milliliters	fluid ounces	.034
quarts	liters	.946	liters	pints	2.113
gallons	liters	3.785	liters	quarts	1.057
ounces	grams	28.349	liters	gallons	.264
pounds	kilograms	.454	grams	ounces	.035
short tons	metric tons	.907	kilograms	pounds	2.205
pound-feet	newton-meters	1.356	metric tons	short tons	1.102
pound-inches	newton-meters	.11296			

Temperature (Exact)

°F	Fahrenheit temperature	5/9 (after subtracting 32)	Celsius temperature	°C
----	---------------------------	-------------------------------	------------------------	----

